



European Aviation Safety Agency – Rulemaking Directorate

Notice of Proposed Amendment 2013-07

Ageing aircraft structures

RMT.0225 (MDM.028(a)) – 23/04/2013

EXECUTIVE SUMMARY

This Notice of Proposed Amendment (NPA) addresses a safety issue related to ageing aircraft structures for large aeroplanes.

This NPA proposes changes to the Implementing Rules, certification standards, Acceptable Means of Compliance and Guidance Material in order to ensure that the safety risks associated with the 'ageing aircraft' issues are mitigated.

With the increased use and longer operational lives of ageing aircraft, there has long been a need for a programme to ensure a high level of structural integrity and furthermore to maintain it in the future. The initial rulemaking task on the 'Development of an ageing aircraft structure plan' was divided into three different tasks. This NPA addresses only large aeroplanes and the subsequent tasks will establish if there is a need to develop continuing structural integrity programmes for other classes of aircraft as well as addressing concerns over the change of the operational use.

To address the existing large aeroplane fleet and to protect the future fleet of large aeroplanes this document proposes the implementation of the following changes:

- (a) amend Part-21 'Certification of aircraft and related products, parts and appliances, and of design and production organisations';
- (b) amend Part-26 'Additional airworthiness requirements for operations' and the corresponding 'Certification Specifications CS-26';
- (c) amend CS-25 'Certification Specifications and the corresponding AMC for large aeroplanes';
- (d) amend AMC 20-20 'Continuing Structural Integrity Programme';
- (e) amend AMC to Part-M 'Continuing Airworthiness Requirements'.

Applicability		Process map	
Affected regulations and decisions:	Part-21, Part-26, CS-26, CS-25, AMC 20-20, AMC to Part-M	Concept Paper:	No
Affected stakeholders:	Large aeroplane TC/RTC/STC holders; applicants for a TC/RTC/STC; design or repair approval; operators; maintenance organisations; competent authorities	Terms of Reference:	2/5/2007
Driver/origin:	Safety	Rulemaking group:	Yes
Reference:		RIA type:	Light
		Technical consultation during NPA drafting:	Yes
		Duration of NPA consultation:	3 months
		Review group:	Yes
		Focused consultation:	Yes
		Publication date of the Opinion:	2015/Q2
		Publication date of the Decision:	2015/Q2

Draft Opinion of the European Aviation Safety Agency

for amending Commission Regulation (EU) No 748/2012 on implementing rules for the airworthiness and environmental certification of aircraft and related products, parts and appliances, as well as for the certification of design and production organisations ('Part-21')

and

for amending Commission Regulation (EU) No .../... on additional airworthiness requirements for operations ('Part-26')

and

amending Decision 201X/XXX/R of the Executive Director of the European Aviation Safety Agency on additional airworthiness specifications for operations ('CS-26')

and

amending Decision 2003/002/RM of the Executive Director of the European Aviation Safety Agency of 17 October 2003 on Certification Specifications, including airworthiness codes and Acceptable Means of Compliance, for large aeroplanes ('CS-25')

and

amending Decision 2003/012/RM of the Executive Director of the European Aviation Safety Agency of 5 November 2003 on Acceptable Means of Compliance for airworthiness of products, parts and appliances ('AMC-20')

and

amending Decision 2003/019/RM of the Executive Director of the European Aviation Safety Agency of 28 November 2003 on Acceptable Means of Compliance and Guidance Material to Commission Regulation (EC) No 2042/2003 on the continuing airworthiness of aircraft and aeronautical products, parts and appliances, and on the approval of organisations and personnel involved in these tasks ('Part-M')

'Ageing aircraft structures'

TABLE OF CONTENTS

A.	EXPLANATORY NOTE	3
I.	GENERAL	4
II.	CONSULTATION.....	4
III.	COMMENT-RESPONSE DOCUMENT (CRD).....	5
IV.	BACKGROUND	5
V.	CONTENT OF THE DRAFT OPINION/DECISION	12
VI.	REGULATORY IMPACT ASSESSMENT	17
B.	DRAFT OPINION(S) AND/OR DECISION(S).....	26
I.	DRAFT OPINION PART-21	26
II.	DRAFT OPINION PART-26	27
III.	DRAFT DECISION CS-26	35
IV.	DRAFT DECISION CS-25	39
V.	DRAFT DECISION AMC 25.571	44
VI.	DRAFT DECISION AMC 20-20	82
VII.	DRAFT DECISION AMC TO PART-M	82
C.	APPENDICES	83
	APPENDIX I: DEFINITIONS AND ACRONYMS.....	83
	APPENDIX II: EXCLUDED AEROPLANES	87
	<u>AMC 20-20 AMDT 1 – CONTINUING STRUCTURAL INTEGRITY PROGRAMME.....</u>	88

A. EXPLANATORY NOTE

I. General

1. The purpose of this Notice of Proposed Amendment (NPA) is to amend the following:
Part-21, Part-26, CS-26, CS-25 (including the AMC), AMC 20-20, and AMC to Part-M.
2. The scope of this rulemaking activity is outlined in the Terms of Reference (ToR) RMT.0225 (MDM.028(a)) and is described in more detail below.
3. The European Aviation Safety Agency (hereinafter referred to as the 'Agency') is directly involved in the rule-shaping process. It assists the Commission in its executive tasks by preparing draft regulations, and amendments thereof, for the implementation of the Basic Regulation¹ which are adopted as 'Opinions' (Article 19(1)). It also adopts Certification Specifications, including Acceptable Means of Compliance and Guidance Material, to be used in the certification process (Article 19(2)).
4. When developing rules, the Agency is bound to follow a structured process as required by Article 52(1) of the Basic Regulation. Such process has been adopted by the Agency's Management Board and is referred to as the 'Rulemaking Procedure'².
5. This rulemaking activity is included in the Agency's Rulemaking Programme for 2014. It implements the rulemaking task RMT.0225 (MDM.028(a)) 'Development of an ageing aircraft structure plan'.
6. This particular NPA will address the ageing structures issues for large aeroplanes only.
7. The text of this NPA has been developed by the Agency based on the contribution of the MDM.028 working group and on the earlier efforts of the Airworthiness Assurance Working Group (AAWG) and the European Ageing Aircraft Working Group (EAAWG). It is submitted for consultation of all interested parties in accordance with Article 52 of the Basic Regulation and Articles 5(3) and 6 of the Rulemaking Procedure.
8. The proposed rule has taken into account the development of European Union and international law (ICAO), and the harmonisation with the rules of other authorities of the European Union's main partners as set out in the objectives of Article 2 of the Basic Regulation.

II. Consultation

9. To achieve optimal consultation, the Agency is publishing the draft decision of the Executive Director on its website. Comments should be provided within **3 months** in accordance with Article 6.4 of the Rulemaking Procedure.
10. Stakeholders are requested to submit proposals for any aircraft type/model which meets the exclusion criteria of compliance with the specific paragraphs of 26.3xx, as further detailed in Section C, Appendix II, of this NPA. Proposals shall be

¹ Regulation (EC) No 216/2008 of the European Parliament and of the Council of 20 February 2008 on common rules in the field of civil aviation and establishing a European Aviation Safety Agency, and repealing Council Directive 91/670/EEC, Regulation (EC) No 1592/2002 and Directive 2004/36/EC (OJ L 79, 19.3.2008, p. 1). Regulation as last amended by Commission Regulation (EU) No 6/2013 of 8 January 2013 (OJ L 4, 9.1.2013, p. 34).

² Management Board Decision concerning the procedure to be applied by the Agency for the issuing of opinions, certification specifications and guidance material (Rulemaking Procedure), EASA MB Decision No 01-2012, 13.3.2012.

submitted within the NPA comments period. Based on the input from the stakeholders, the list of excluded aircraft will be published in Appendix I to Part-26.

11. Please submit your comments using the automated Comment-Response Tool (CRT) available at <http://hub.easa.europa.eu/crt/>³.
12. The deadline for the submission of comments is **23 July 2013**.

III. Comment-Response Document (CRD)

13. All comments received in time will be responded to and incorporated in a Comment-Response Document (CRD). The CRD will be available on the Agency's website and in the Comment-Response Tool (CRT).

IV. Background

14. General

What is an ageing aircraft? Any aircraft could be considered to be ageing from the moment of manufacture. The age of an aircraft depends on factors including chronological age, number of flight cycles, and number of flight hours. Individual aircraft components age differently, and some of the ageing mechanisms are fatigue through repetitive cycles, wear, deterioration and corrosion. Since these factors will increase the pace and effects of the ageing process, they can be a significant safety concern if not properly understood and managed throughout the life of the aircraft.

Service experience has shown that there is a need to have continuing updated knowledge of the structural integrity of aircraft, especially as they become older. The structural integrity of aircraft is of concern because such factors as fatigue cracking and corrosion are time and usage dependent, and our knowledge about them can best be assessed based on real-time operational experience and the use of the most modern tools of analysis and testing.

Many aircraft accidents around the world have been linked to ageing aircraft. The major structural damage of the pressurised fuselage of an Aloha Airlines Boeing 737 was attributed in part to the age of the aircraft and the combination of fatigue and corrosion effect.

Fatigue

Fatigue occurs through application of cyclic loading and is inevitable in the aluminium alloy materials predominantly used in the current world fleet. The link between loading cycles and fatigue initiation and crack growth establishes an obvious association between fatigue-related ageing and the number of flight cycles/hours accumulated by an aircraft.

Damage Tolerance (DT)

The principle of DT is that although cracks may initiate due to fatigue and then subsequently propagate, the process can be understood and managed by inspection, repair and, on a case-by-case basis, terminating modification. Inspections based upon a DT philosophy play a major role in detecting the cracks before they can affect safety. Testing and analysis is used to determine inspectable defect sizes, crack growth rates, critical crack length and associated residual strength to determine inspection thresholds and intervals.

³ In case the use of the Comment-Response Tool is prevented by technical problems, please report them to the CRT webmaster (crt@easa.europa.eu).

Corrosion

Corrosion in airframes is usually in the form of an electrochemical oxidation of the metal alloy. It is more prevalent in marine and coastal environments due to high humidity and exposure to salt. Corrosion weakens the material, both reducing the effective cross section and creating locations of stress concentration. To slow down the corrosion rate careful material selection, surface coatings and other design considerations such as effective drainage are employed. Corrosion combined with fatigue is of greatest concern.

Widespread Fatigue Damage (WFD)

WFD in a structure is characterised by fatigue damage originating cracks at multiple locations of sufficient size and density, to the extent that the structure no longer maintains its required residual strength. Traditional application of damage tolerance analysis from a single or dual crack origin is not sufficient to preclude WFD. Fatigue cracks related to WFD can grow quickly and interact in such a way that an operator cannot inspect the susceptible structures effectively or often enough to ensure detection of the cracks before they lead to a structural failure. A separate WFD assessment and determination of specific maintenance actions is necessary to adequately address WFD.

The Aloha Airlines accident highlighted the issues associated with WFD, and in particular Multiple Site Damage (MSD) which is the presence of multiple fatigue cracks in the same structural element. Multiple Element Damage (MED), the other form of WFD, is the presence of fatigue cracks in adjacent structural elements. To preclude WFD, operation should not be allowed beyond a certain point in the life of the airframe, known as the limit of validity of the structural maintenance programme.

Limit of Validity (LoV)

LoV is not more than the period of time, stated as a number of total accumulated flight cycles or flight hours or both, for which it has been demonstrated that WFD is unlikely to occur in the aircraft structure; and that the inspections and other maintenance actions and procedures resulting from this demonstration and other elements of the fatigue and damage tolerance evaluation are sufficient to prevent catastrophic failure of the aircraft structure. The LoV terminology is usually used in the context of 'Limit of validity of engineering data that supports the structural maintenance programme'. The term 'structural maintenance programme' refers to the structure's part/section of the maintenance programme.

15. Approaches to aircraft ageing issue

How can we address the ageing issue and what is the priority? There are two basic directions in managing the ageing aircraft issue: address the current ageing fleet and improve the requirements for future aircraft designs.

While planning to protect the future fleet is important, there is a necessity to adequately maintain the existing aircraft in order to control their ageing. The economic benefit of operating certain older technology aircraft has resulted in the operation of many such aircraft beyond their previously expected retirement age. In addition, there may be an accumulation of modifications and repairs whose effects were not considered as part of the original design.

To manage fatigue, since the current large aeroplane fleet first entered service, different design and certification techniques were implemented: safe-life, fail-safe, and in the late 1970s Damage Tolerance (DT).

DT remains the best practice for the majority of structural configurations, so older aircraft certified prior to DT requirements will need to be addressed first.

What about the future fleet? The certification basis to which the aircraft is built has a major influence on the level of safety throughout the life of the aircraft. The safety level required for new designs should, therefore, not be less than the one being implemented for ageing aircraft.

16. International efforts and ageing aircraft solution key components

In June 1988, the FAA sponsored a conference on ageing aircraft. As a result of that conference, an ageing aircraft task force was established in August 1988 as a subgroup of the FAA's Research, Engineering, and Development Advisory Committee, representing the interests of the aircraft operators, aircraft manufacturers, regulatory authorities, and other aviation representatives. The task force, then known as the Airworthiness Assurance Task Force (AATF), set forth five major elements of a programme for keeping ageing fleet safe.

For each aeroplane model in the ageing aeroplane fleet these elements consisted of the following:

- (a) select service bulletins describing modifications and inspections necessary to maintain structural integrity;
- (b) develop inspection and prevention programmes to address corrosion;
- (c) develop generic structural maintenance programme guidelines for ageing aeroplanes;
- (d) review and update the Supplemental Structural Inspection Documents (SSID) which describe inspection programmes to detect fatigue cracking; and
- (e) assess damage tolerance of structural repairs.

Subsequent to the five major elements being identified and detailed above, it was recognised that an additional factor in the Aloha Airlines accident was WFD.

Regulatory and industry experts agreed that, as the transport aircraft fleet continues to age, the occurrence of WFD is eventually inevitable. Therefore, the FAA determined, and the Agency concurred, that notwithstanding the fatigue and DT requirement in place since 1978, a WFD evaluation must be added to the ageing aircraft programme.

Structures Task Groups sponsored by the Task Force were assigned the task of developing these elements into usable programmes. The Task Force was later re-established as the Airworthiness Assurance Working Group (AAWG) of the Aviation Rulemaking Advisory Committee (ARAC). Although there was JAA membership and European operators and industry representatives participated in the AAWG, recommendations for action focused on FAA operational rules which are not applicable in Europe. It was, therefore, decided to establish the European Ageing Aircraft Working Group (EAAWG) on this subject to implement ageing aircraft activities into the JAA regulatory system, not only for the initial 'AATF 11' aircraft, but also other old aircraft and more recently certified ones. This resulted in amendments to JAR-OPS Subpart M and then to Part-M that acknowledge the need for ageing aircraft programmes and facilitate their implementation. The current AMC 20-20 was based on the work of EAAWG with subsequent Agency revision to accommodate developments in the ageing aircraft philosophy.

17. Conclusion

It is acknowledged that the various competent authorities, type certificate holders, and operators have continually worked to maintain the structural integrity of older aircraft on an international basis. This has been achieved through an exchange of in-service information, subsequent changes to inspection programmes, and by the

development and installation of modifications on particular aircraft. However, it is evident that with the increased use, longer operational lives and experience from in-service aircraft, there is a need for a programme to ensure a high level of structural integrity and maintain it in the future for all aircraft, and in particular those in the large aeroplanes category. Furthermore, there is a need to ensure a common standard of development and implementation of these programmes throughout Europe and, as far as possible, to harmonise with other authorities.

18. The ToR for task RMT.0225 (MDM.028(a)) were published on 2 May 2007, together with the Group Composition of the task.

The overall objective identified in the ToR is to develop the technical elements for an ageing aircraft structure plan as well as to implement it to the fleet. This plan will include proposal for actions (mandatory or not), implementation dates, affected aircraft and organisations, and proposal for CS modifications.

19. Explanations on some of the terminology used through the NPA

What is a Design Approval Holder (DAH): The term is used frequently in the AMC 20-20 and other ageing aircraft documentation and represents a holder of any design approval including TCHs, RTCHS, STCHs or earlier equivalent or repair approval holders.

Applying for the LoV extension: Anybody can be an applicant for an LoV extension; however, a TCH will be the typical applicant. An applicant for an LoV extension must perform DTE (of type design configuration) and must consider WFD.

Supporting the LoV extension: To extend the LoV of an individual aircraft maintenance programme, the operator needs to ensure all repairs and modifications have DTI and other applicable maintenance actions based upon a fatigue and damage tolerance evaluation that includes consideration of WFD up to the extended LoV. This is achieved by engaging the support of existing design approval holders or applicants to provide this additional approved data as necessary. DAHs supporting the LoV extension have to demonstrate compliance with Part 26.350(b).

Future change or future repair: A future change or future repair are changes and repairs which are approved after the entry into force of this rule.

Existing change or repair: An existing change or repair is a change or repair which is approved before the entry into force of this rule.

20. How are different design approval holders or the applicants for design approval impacted?

Generally the DAHs or applicants for TC/STC/design and repair approvals will need to produce the necessary data, procedures, instructions and manuals and make them available to those who need them (operators).

The following highlights are only summarising the main responsibilities. For the complete list please refer to the rule.

— **TCHs/Applicants for TC:**

- Unless previously accomplished, all TCHs/applicants for TC must create an ALS, perform a fatigue and damage tolerance evaluation (DTE) of the aeroplane structure and include the DTI in the ALS, establish a baseline Corrosion Prevention and Control Programme (CPCP), establish a process that ensures that unsafe levels of fatigue cracking will be precluded in service and identify fatigue-critical structure.

- For large aeroplanes with an MTOW above 34 019 kg (75 000 lbs), must establish an LoV and include it in the ALS, develop maintenance actions that support the LoV, and perform WFD evaluation of all future type design changes.
 - Must provide operators with sufficient data to ensure the continued safe operation of ageing aircraft in a standardised manner.
 - For large aeroplanes with a maximum capacity of 30 passengers or more, or a payload of 3401,9 kg (7 500 lbs) or more, must review existing design changes/repairs, develop a REG and perform a DTE and develop a Damage Tolerance Inspection (DTI) for changes/repairs affecting the fatigue-critical baseline structure (FCBS).
 - If applying for future repairs and changes, must perform a DTE, develop a DTI and submit it for Agency approval.
- **STCHs(or equivalent)**
- For large aeroplanes with a maximum capacity of 30 passengers or more, or a payload of 3401,9 kg (7 500 lbs) or more, must review changes and published repairs and perform DTE and develop DTI for changes and published repairs affecting FCS.
- **STC/applicants for approval of a design change or repair:**
- Will have to perform a DTE of future repairs and changes and develop inspections and any other necessary procedures to preclude fatigue failure.

21. How are operators impacted?

- The DAHs are responsible to make the DTI available. However, in cases where the DAH no longer exists or is unable to provide the data, the operator is required to obtain appropriate DTI. This data will need approval through Part-21 requirements and associated processes.
- The necessary data, procedures, instructions, and manuals as produced by the TC and STC holders in accordance with Part-26 requirements need to be properly implemented. MA 302 (g) requires periodic review of the structural maintenance programmes taking into account new and/or modified maintenance instructions promulgated by the Design Approval Holders (DAHs).
In addition to the existing provisions of Part-M, Part-26 explicitly defines implementation requirements and the associated compliance times.
- If applying for an LoV extension (of the structural maintenance programme). Repairs and modifications are subject to fatigue and DTE considering WFD. Operators must ensure that the appropriate approved data is obtained for each installed repair and modification and all future repairs and modifications up to the extended LoV.

22. How are competent authorities impacted?

- They will be responsible for ensuring that operators implement correctly Part-26 and Part-M requirements related to the ageing aircraft continuing structural integrity programmes.

What are the differences between EASA and FAA approaches?

The following table explains the differences resulting from the proposed requirements.

No	Part-26	EASA proposal	Difference to FAR
1	26.300	Proposes TCH to develop a list of Principal Structural Elements (PSEs) in addition to Fatigue-Critical Structures (FCSs). This will reduce the risk of confusion regarding the criticality of structural elements, some of which will be critical for fatigue as addressed by this rulemaking and others for conditions such as impact, e.g. composites PSEs. Additionally, this will promote a consistent and complete compliance with Part-26 and 25.571.	FAA does not require a list of PSEs to be established, although under 25.571 Amdt 45 onward they have to be identified, so the EASA proposal is not a significant burden.
2	26.300	Requires a baseline CPCP and a DTE to be produced for all large aeroplanes, EASA approved and made available to operators. Ensures a level playing field and consistent availability of a baseline CPCP and DTE to operators. It is more efficient for the Agency as it does not have to manage the CPCP and DTE (e.g. SSIDs) using individual ADs.	FAA either mandate existing CPCP through ADs or it is controlled through MRBR containing the CPCP. Both of these approaches satisfy the EASA requirement. FAA have no operational requirement or DAH rule, but consider that most of the existing fleet have a CPCP or equivalent ICA and the delta is addressed via ADs (see proposed CPCP rule withdrawal FR DOC 04-18633). FAA requires DTEs to be implemented operationally through FAR Part 121 plus ADs.
3	26.300	Requires additional information in the ALS e.g. SSID by reference. This ensures SSID availability and implementation by the operator through Part M.	FAA implement SSID by AD in some cases (not operator dependent) and Part 121 and 129 require an FAA approved DT based inspection programme for baseline structure. Net result is similar.
4	26.300	Requires TCH to develop specific elements of a Continuing Airworthiness (CAW) programme to prevent unsafe cracking, including monitoring of fleet usage and comparison to certification assumptions and assessment of the need for mandatory changes.	No parallel FAA requirement.
5	26.350	Requires a WFD evaluation of all future and existing repairs on aircraft subject to an extended LoV. This is because EASA has no data that would support safe operation with such repairs up to an indeterminate extension of an LoV. The proposal ensures no reduction in safety subsequent to implementation of an	For Part-25 pre-Amdt 96 aircraft, FAA does not require consideration of WFD for repairs at any stage of the aircraft's life.

		extended LoV.	
6	26.350	Requires a WFD evaluation of all future and existing modifications on aircraft subject to an extended LoV. This is because EASA has no data that would support safe operation with such modifications up to an indeterminate extension of an LoV. The proposal ensures no reduction in safety subsequent to implementation of an extended LoV.	FAA does not require WFD evaluation for existing STC at any stage of the aircraft's life. For future STCs, unless it is determined through the CPR that compliance with the latest certification basis is required, no WFD evaluation will be performed. EASA will follow the same approach for future STCs up to the LoV.
7	26.360	Requires DTE for future changes and repairs for all large aeroplanes for the following reasons: To maintain the established DT safety standard, and post-baseline DTE implementation. To prevent a repair/change from adversely affecting the validity of inspections required by the SSID/ALS. <i>NOTE:</i> The majority of aircraft operating in the EU are post-JAR Change 7/Amdt 45 and, therefore, require DTE anyway, so this is not a substantial burden.	FAR Part-26 does not require DTE for future repairs and changes for aircraft with less than 30 pax and 3401,9 kg (7 500 lbs) payload.
9		EASA does not require a compliance plan. Part-21 and Part-26 define the requirements which need to be complied with in the EASA regulations.	FAA requires a compliance plan (26.49).
10		Operators implementation of the ageing aircraft structure integrity requirements will be achieved through Part-26 and Part-M. EASA may also mandate actions required to prevent WFD using Airworthiness Directives, in a similar manner to the FAA.	FAA requirements are implemented operationally through Part 121 and Part 129 plus ADs for some existing programmes such as SSIDs, mandatory modifications and CPCPs.

V. Content of the draft Opinion/Decision

23. Why introduce the ageing aircraft requirements through Part-26?

The introduction of the 'Ageing aircraft' requirements in Part-26 ('Additional operational requirements for operations') was necessary since the new provisions in the existing airworthiness codes are only applicable to new design and in some cases to significantly changed design.

Part-26 will provide the high-level requirements and will ensure that the rules are binding. The necessary flexibility for the technical details on how to comply with these rules and the related guidance material are captured in CS-26 and AMC 20-20.

The Part-26/CS-26 regulation framework was based on JAR-26. In order for the JAR-26 requirements to become binding, they had to be transposed into the national laws by the JAA member countries. JAR-26 requirements (often called 'retroactive airworthiness requirement') were invoked through a provision in JAR-OPS 1 transposed into Annex III to Council Regulation (EEC) 3922/91 as 'EU-OPS'.

Since it is based on JAR-26, Part-26 was intended to keep the document structure where possible. Therefore, the 'Ageing aircraft' requirements were placed in Subpart B of Part-26 which is referring to large aeroplanes. However, the 'Ageing aircraft' subject is introduced for the first time by this NPA in Subpart B of Part-26 and has no correspondent with JAR-26.

The concept of Part-26 is further detailed in NPA 2012-13 titled 'Additional airworthiness requirements for operations', available at <http://easa.europa.eu/rulemaking/docs/npa/2012/NPA%202012-13.pdf>.

24. Part-21

Requirements are introduced in Part-21 to make the appropriate links with Part-26 for different applicants in the following scenarios:

- 21.A.21 Issue of a type certificate. Requirements are introduced for the type certificate applicant to comply with Part-26.
- 21.A.101 Designation of applicable certification specifications and environmental specification requirements. Requirements are introduced for applicants for a change to a type certificate to comply with the requirements for applicants for a change to a type certificate of Part-26.
- 21.A.433 Repair design. Requirements are introduced for the applicants for approval of a repair design to comply with Part-26.

25. Part-26

Seven new paragraphs (26.300, 26.310, 26.320, 26.330, 26.350, 26.360 and 26.370) were added in Part-26, Subpart B (Large aeroplanes)

- 26.300 Continuing Structural Integrity Programme for Ageing Aircraft Structures — General requirements — Type Certificate Holders and Applicants for Type Certificates.

This paragraph introduces general requirements for the TCH that will result in a comprehensive continuing structural integrity programme for the type.

- 26.310 Design changes impact on the LoV — Type Certificate Holders and applicants for Type Certificates.

This paragraph supplements 26.300 by ensuring that future changes are evaluated for WFD by the TCH.

- 26.320 Damage Tolerance data for existing repairs, existing changes and existing repairs to changes to Fatigue-Critical Structure — Type Certificate Holders and applicants for Type Certificates.

This paragraph supplements 26.300 by ensuring that TCHs evaluate existing changes and published repairs for DT and provide operators with e means to evaluate existing repairs (the Repair Evaluation Guidelines (REG)). Existing repairs or changes mean repairs or changes to the type which are approved before the entry into force of this rule.

- 26.330 DT data for existing STCs and repairs for STCs

This paragraph supplements 26.300 by ensuring that changes and repairs to changes under the responsibility of STHs are provided with DTI.

It is also noted the applicability of this paragraph to include holder of major design changes that has been deemed to be approved in accordance with Article 4 of Regulation (EU) No 748/2012.

- 26.350 Extension of an LOV — TCH, STCH and holders of type design changes other than TCH and STCHs

This paragraph provides instructions for the applicants for LoV extension and for the applicants for change and repair approval affecting FCS.

- 26.360 Fatigue and Damage Tolerance Evaluation of Future Repairs and Changes — TCHs, STCHs and holders of changes and repairs

This paragraph ensures that the applicants for repair/design change approval perform a DTE and develop inspections and other procedures to preclude a catastrophic failure, and the required compliance times.

- 26.370 Maintenance programme

This paragraph provides the operators with instructions to revise the maintenance programme to ensure continuing structural integrity largely based on DAH documentation, instructions to extend the LoV and required compliance times.

26. Appendix I to Part-26

It will contain the list of aircraft excluded from compliance with certain ageing aircraft-related paragraphs included in Part-26. The list will be sorted by Part-26 paragraph number.

- Criteria for exclusion of certain types and models are proposed in Appendix II of Section C of this NPA.
- Additionally, the Agency may take into account the number of aircraft subject to the rule, the type of operation, and their likely remaining service life.
- Stakeholders are requested to submit proposals for any aircraft type/model which should be excluded. Proposals shall be submitted within the NPA public consultation period. Based on the input from the stakeholders the list of excluded aircraft will be published in Appendix I to Part-26.

27. CS-26

Certification Specifications were developed for the corresponding Part-26 paragraphs following the principles proposed in NPA 2012-13.

Explanations on compliance demonstration with Part-26 are provided.

28. CS-25 Book 1

- Paragraph 25.571(a)(1)(ii) is now changed to specify those structural elements whose failure would 'contribute' rather than 'cause' catastrophic loss of the aeroplane. This aligns with the definition of Principal Structural Element (PSE) in the AMC definitions.
- New paragraph 25.571(a)(3) introduces the need to specify an LoV of the structural maintenance programme of the aircraft. This will effectively be mandated by requiring its inclusion in the Airworthiness Limitations Section (ALS) of the Instructions for Continued Airworthiness (ICA) as required by CS 25.1529. The aircraft will not be allowed to be operated beyond this limit, unless the limit is revised and further actions are taken to ensure the continuing airworthiness of the ageing structure. Further guidance on the necessary actions may be found in AMC 20-20 and the proposed AMC 25.571.
- New paragraph 25.571(a)(4) defines the circumstances for allowing safe-life evaluation in lieu of fatigue and damage tolerance evaluation and requires a threshold for inspection to be established for certain types of structure considering the possibility of manufacturing flaws and service damage being introduced into the structure.
- New paragraph 25.571(a)(5) requires that the environmental and accidental damage assessments that have for many programmes been the remit of the Maintenance Review Board (MRB) alone, to be now clearly considered as part of compliance with CS 25.571. This paragraph also provides a definition of Level 1 corrosion and a requirement that the ALS must include a statement that requires the operator to include a CPCP in their maintenance programme that will ensure corrosion is controlled to Level 1 or better.
- Paragraph 25.571(b) now specifies that sufficient full scale fatigue testing be performed to ensure WFD at multiple sites (namely Multiple Site Damage (MSD) and Multiple Element Damage (MED)) will not occur within the LoV of the aeroplane. This does not remove the requirement to support the complete fatigue and damage tolerance evaluation with test data. For a new and complex design, full-scale test is typically required to satisfy this requirement. This is especially important to identify potential hot spots and ensure that inspection thresholds are appropriate.
- The concession to use lower values of limit load for residual strength assessment if the damage is readily detectable has now been removed from 25.571 (b).
- The limit symmetrical manoeuvring condition specified in 25.571(b)(1) has been clarified to incorporate CS 25.331–CS 25.345 instead of CS 25.337–CS 25.345.
- Paragraph CS 25.571(e) specifies amended discrete source damage requirements. Currently, these include bird strike and sudden decompression of compartments as specified in CS 25.365(e) and (f). Bird impact has been retained and the text clarified, whereas sudden decompression has been removed as it is adequately covered by CS 25.365. Two further discrete damage sources present in FAR § 25.571(e) addressing uncontained engine and APU rotor failure were considered once again for inclusion as although they had previously been removed from JAR 25.571 and added to Advisory Material supporting JAR/CS 25.903 (d)(1), the General Structure Harmonisation Working Group (GSHWG) had proposed to reinstate them in § 25.571(e). Reintroducing the requirement for resistance to all likely damage according to the failure models of AMC 20-128 could prevent, without further rulemaking, the consideration of certain failures under the risk analysis of

AMC 20-128. This allowance is applicable only after taking all practical design measures to minimise the risk of catastrophic failure due to Uncontained Engine Rotor Failure (UERF). EASA has, therefore, concluded that CS 25.903(d)(1) and AMC 20-128A remain adequate to address the essential requirements for airworthiness. Note that when addressing CS 25.903(d), AMC 20-128A currently refers to the ACJ 25.571(a) for consideration of structural damage due to UERF and this should be read until further notice as AMC 25.571, which itself is revised to reflect this link.

- Several minor editorial revisions are also being proposed.
- H25.1 'General' point (c) is added making reference to AMC 20-20.
- H25.4 'Airworthiness Limitation Section' point (a)(4) has been added to show that the ALS must contain an LoV.

29. AMC 25.571

- AMC 25.571(a), (b) and (e) and AMC 25.571(b) and (e) have been replaced by a new AMC 25.571.
- In addition to the text being reformatted, some of the more obvious differences compared to the previous two AMCs are highlighted below.
- Definitions of the terms used in the text have been included in paragraph 4.0.
- The introduction in paragraph 6.0 now contains a synthesis of the whole AMC with a short summary of all the main topics addressed.
- DTE in paragraph 7.0 notes those areas of design and analysis that should be considered, and includes an enhanced selection of criteria when determining PSEs. Guidance on residual strength testing has been amplified and provides guidance on simulated cuts that may be required when testing.
- Inspection requirements of paragraph 8.0 have been substantially enhanced and provide detailed guidance on an acceptable means of deriving threshold inspection periods. The derivation means are different for different categories of structure, i.e. structure that requires no special inspections and structure that does require special inspection. The latter is then divided into single load path structure and non-single load path structure. The Fatigue Evaluation of paragraph 9.0 is unchanged.
- Guidance for evaluation of Discrete Source Damage (DSD) in paragraph 10 now includes reference to AMC 120-128A which is the Guidance Material provided for CS 25.903(d) that addresses uncontained engine rotor failure.
- A new paragraph 11 has been added that addresses the subject of LoV of the structural maintenance programme. It identifies the association of the LoV with the fatigue test and teardown results required for assessment of the onset of WFD, and the necessity to state this limit in the airworthiness limitations section of the ICA, as required by CS 25.1529 Appendix H, which has been modified to note this.
- Thereafter, the AMC includes several appendices that provide information that helps support the general AMC material.

30. AMC 20-20

- AMC 20-20 has been updated to be aligned with the latest Part-26 references as well as minor editorial changes.

31. AMC M.A.302

- The operator is responsible for incorporating approved DAH documents necessary to maintain airworthiness into their aircraft specific maintenance programmes, in accordance with Part-M (Ref. M.A.302).
- Without prejudice to the EASA interpretation and the competent authority interpretation of Part-M requirements and the ongoing RMT.056 related to ICA, Part-26 specifies the requirements for operators that will ensure a standardised implementation of specific actions related to continuing structural integrity for ageing aircraft structures.

VI. Regulatory Impact Assessment

1. Process and consultation

The rulemaking group responsible for this task has included experts representing large aeroplanes manufacturers, airlines and aviation authorities. This activity has started with the assumption that there is a need for regulatory action. The proposed rules have considered the existing industry practices with the intent to minimise the impact of the introduction of new requirements.

2. Issue analysis and risk assessment

2.1. Issue which the NPA is intended to address and current regulatory framework

This rulemaking task focuses on mitigating the risks of ageing aircraft for turbine-powered large aeroplanes only. This task is addressing the development of the certification requirements for ageing aircraft, and it also focuses on how these requirements are implemented for existing and future fleet.

While the core requirements for design approval holders are introduced through the recently proposed Part-26, the requirements for operators are also introduced through Part-26 and Part-M and the correspondent guidance material.

2.2. Who is affected?

The sectors affected include approximately 28 large aeroplane TCHs, 90 DOA having in their scope structures for large aeroplanes, 1 200 STC affecting large aeroplane structures, 650 operators of large aeroplanes representing 7 200 large aeroplanes, potentially several hundred MRO for large aeroplanes worldwide (around 150 in Europe).

2.3. What are the risks?

The risk identified is the lack of consistent implementation of the ageing aircraft requirements, which could lead to WFD and other forms of structural fatigue failure with an increased probability of accidents and incidents involving sudden depressurisations, loss of control and catastrophic structural failure resulting in potential loss of life or other damages.

The Agency has already published AMC 20-20 which provides guidance but does not mandate requirements to address the ageing aircraft issue. The actual impacts of AMC 20-20 would depend on how many of the affected stakeholders choose to implement it for their existing fleet.

3. Objectives

The purpose of this rulemaking task is to develop the technical elements for an ageing aircraft structure plan and mitigate the risk of ageing for large aeroplanes by mandating actions for future aircraft and for the existing fleet.

4. Options identified:

Option 0	<p>Do nothing. Voluntary compliance (existing AMC 20-20).</p> <p>Allow the industry to develop its own structural integrity programmes under the Agency's guidance.</p>
Option 1	<p>Provide mandatory requirements.</p> <p>Develop ageing aircraft structures requirements for the existing and for the future fleet.</p>

5. Analysis of the impacts

5.1. Safety impact

Structural fatigue failure has caused a number of ageing aircraft accidents. The following are highlights of some fatigue and corrosion related accidents.

5.1.1. WFD failure

— *Aloha Airlines accident*

An early illustration of the extent to which the controls against fatigue failure introduced during the early years of the 'jet age' might be inadequate was delivered by a 1988 incident to a 19-year-old Boeing 737-200, which on an internal flight in Hawaii suffered sudden structural failure and an explosive decompression at FL240. Nearly 6 metres of cabin skin and structure aft of the cabin entrance door and above the passenger floor line separated from the aircraft.

The investigation found de-bonding and fatigue damage which had led to the failure. For that aircraft, at least, the introduction of static test hulls with simulated hours and cycles kept well ahead of equivalent in-service aircraft was not sufficient. This aircraft had completed 89 680 flight cycles with an average flight time of only 25 minutes, almost all of them in the marine environment of the Hawaiian Islands, a somewhat atypical service life which was considered to have allowed corrosion to increase the likelihood of fatigue.

See the NTSB investigation summary and the Safety Recommendation at:
http://www.nts.gov/doclib/reclib/1989/A89_70_72.pdf

— *Grumman G73T accident*

An example of dramatic and fatal structural fatigue was a 58-year-old Grumman G73T Turbo Mallard Seaplane which in 2005 shed the complete right-hand wing whilst on a domestic revenue flight in the USA when the main spar failed.

The investigation found that the right wing separated from the aircraft because of multiple pre-existing fatigue fractures and cracks which reduced the residual strength of the wing structure.

Other examples of WFD occurring in the fleet include: an in-flight Lockheed Model L-1011 failure of aft pressure bulkhead stringer attach fittings; a McDonnell Douglas Model DC-9 aft pressure bulkhead cracks; Boeing Models 727 and 737 lap splice cracking; Boeing Model 767 aft pressure bulkhead cracking; and Boeing Model 747 and Airbus A300 frame cracking.

WFD and structural fatigue failure have already resulted in a number of aircraft accidents or even losses. If the current knowledge and better controls provided through option 1 were implemented, the risk of such failures would have been mitigated.

See the NTSB investigation summary at:

<http://www.nts.gov/investigations/summary/AAR0704.html>

5.1.2. Corrosion

— *FEAT Boeing 737 accident*

FEAT's (Far Eastern Air Transport) Boeing 737 B-2603 was used extensively on domestic flights within Taiwan since the time it has been acquired from United Airlines. On August 22, 1981 the 737 took off from Taipei on a flight to Makung (MZG). Ten minutes after take-off, there was a loss of cabin pressure. The flight crew returned to Taipei, where repair work was carried out. Later that day when

the aircraft entered service again, it suffered an explosive decompression and disintegrated.

Probable cause: 'Extensive corrosion damage in the lower fuselage structures, and at a number of locations there were corrosion penetrated through pits, holes and cracks due to intergranular corrosion and skin thinning exfoliation corrosion. In addition, the possible existence of undetected cracks due to the great number of pressurization cycles and the interaction of these defects and the damage, resulted in a rapid decompression and sudden break of passenger compartment floor beams and connecting frames, cutting control cables and electrical wiring and eventually loss of power, loss of control, midair disintegration.'

Numerous ADs addressing corrosion have been issued for large aeroplanes and this indicates that corrosion can be a significant issue if not properly controlled by AD (Airworthiness Directives) or regulations.

5.1.3. Older repairs, corrosion

A survey conducted by the ARAC AAWG showed that on 246 alterations installed on the fleets of 10 operators, 171 did not have DT data, and that 24 of the 171 were deemed complex.

Early fatigue or fail-safe requirements (pre-Amdt 45) did not necessarily provide for timely inspection of critical structure so that damaged or failed components could be dependably identified and repaired or replaced before a hazardous condition developed. Furthermore, it is known that application of later fatigue and damage tolerance requirements to repairs was not always fully implemented according to the relevant certification bases.

Even the best maintained aircraft will accumulate structural repairs when being operated. The AAWG conducted two separate surveys of repairs placed on aircraft to collect data. The evaluation of these surveys revealed that 90 % of all repairs found were on the fuselage, hence these are a priority and RAPs have already been developed for the fuselage pressure shell of many large transport aeroplanes not originally certified to damage tolerance requirements. 40 % of the repairs were classified as adequate and 60 % of the repairs required consideration for possible additional supplemental inspection during service. Nonetheless, following further studies by the AAWG working groups it has been agreed that repairs to all structure susceptible to fatigue and whose failure could contribute to catastrophic failure will be considered (Ref. AAWG Report: Recommendations concerning ARAC taskings FR Doc 04-10816, Re: Ageing Airplane safety final rule. 14 CFR 121.370a and 129.16.).

— China Airlines Boeing 747 accident

The accident of the B-747 of China Airlines on 25 May 2002 and the accident of the B-747SR of Japan Airlines on 12 August 1985 can be highlighted here: both were due to improperly executed repairs. Although the primary purpose of the action for ageing aircraft is not to detect improperly performed repairs, the intended review might detect such cases, thus further enhancing fleet safety.

As aircraft operate into high cycles and high times, the ageing repaired structure needs the same considerations as the original structure in respect of damage tolerance.

5.1.4. Summary of safety impacts per option

Option 0	<ul style="list-style-type: none"> – Voluntary compliance: the safety impact will depend on the degree the AMC 20-20 is implemented. At the beginning the impact may be neutral; however, the safety level would eventually degrade in time. – May lead to sporadic development of many of the technical elements of the ageing aircraft structural integrity programme and would not ensure consistent application of those principles to the existing fleet. – Since there is no rule to be enforced, we run the risk of increasing incidents/accidents related to ageing aircraft. This may lead to ad hoc actions by the authorities (e.g. Airworthiness Directives, grounding the fleet).
Option 1	<ul style="list-style-type: none"> – It ensures that appropriate requirements are mandated and the objective of mitigating the risk of ageing aircraft structures is clearly met. This will lead to the prevention of some accidents. – Enhancement of the safety level of the whole fleet compared to the potential Airworthiness Directives which can only restore the safety level on a case-by-case basis, while the fleet may remain at risk. – Would ensure consistent application of the ageing aircraft structural integrity programme to the existing fleet. – It would also appropriately address the safety recommendations received on ageing aircraft.

5.2. Social impact

None.

5.3. Environmental impact

None.

5.4. Economic impact

Option 0:

Cost will depend on the number of stakeholders implementing the AMC. Cost could, however, be similar to option 1, if all stakeholders choose to implement the AMC.

Option 1:

Potential cost to TCHs

TCHs cost will initially increase through the application of this rule due to:

1. Additional testing and analysis

It should be noted that in principle additional testing is required for new designs (CS-25 Amdt X) and, depending on the economic viability of the proposed LoV, also for compliance with the retroactive requirements (Part-26).

Furthermore, CS-25 Amdt X will be applicable to all large aeroplanes, not only to those above 34 019 kg (75 000 lbs).

However, no significant economic impact is envisaged for new type designs, nor for existing designs, as implementation of the current EASA requirements necessitates full-scale fatigue testing and fatigue and damage tolerance analysis. The additional focus the new requirements bring on WFD is in reality a very small part of the overall costs of fatigue and DT evaluation.

2. Additional design effort

Part 21.101 will require a new certification basis including CS-25 Amdt X (LoV/WFD) for significant changes. This would address changes that can influence WFD, such as freight door conversions, winglets, and significant weight increases. This would mean that the impact of the new requirement would add to the cost compared with the previous requirements, where testing of such changes has been historically less extensive. It is noted that FAA has already published Amdt 132 which includes the requirement for LoV and testing.

For actions related to damage tolerance evaluation, corrosion control and continued airworthiness processes the majority of TC holders will already have the essential technical elements in place for the baseline structure.

3. Additional specific support provided to operators

Assistance provided to operators implementing the ageing aircraft programme will increase the initial cost; however, this may be offset by the need to support operators at short notice in case of in-service findings or incidents.

The TCH cost would be further mitigated considering that the majority of TCHs would have already complied with the US AASR and WFD requirements, reducing costs related to damage tolerance for repairs and modifications and LoV.

To maximize the safety benefit and avoid imposing unnecessary cost for the Ageing Aircraft rule implementation, the following criteria for allowing certain large aeroplanes to be excluded from compliance to the Ageing Aircraft rule for existing designs are proposed.

1. For foreign products, no large aeroplanes are operated under the EASA operating requirements and it is unlikely that any will do so in the future; or
2. for foreign products, some large aeroplanes are operated under the EASA operating requirements; however, none is foreseen to be operating after the rule compliance date. It is unlikely that any will return to service in the future; or
3. An EU Member State is the State of design, some large aeroplanes are operated under the EASA operating requirements or by a foreign carrier; however, none is foreseen to be operating after the rule compliance date. It is unlikely that any will return to service in the future.

In addition to the above proposed exemption criteria, EASA may take into account the number of the aircraft subject to the rule, the type of operation and their likely remaining service life.

Stakeholders are requested to submit proposals for any type design which they believe meets the criteria for exclusion within the NPA public consultation period (see Section II 'Consultation').

TCH for TC below 34 019 kg (75 000 lbs) will not be required to comply with the retroactive WFD rule. The rationale may be summed up as follows:

1. No compelling evidence that we should mandate at this time;
2. Common EASA, FAA, TCCA, and ANAC position;

3. A significant number of aircraft is excluded, but risk is controlled by:
 - continuing monitoring of the fleet (IORS);
 - many of these aircraft have been fatigue tested to several life times;
 - typically smaller aircraft have fewer susceptible locations;
 - further review with FAA, TCCA and ANAC prior to the major types concerned exceeding their DSG.

Potential cost to STCHs

Overall STC costs could be mitigated by the following:

Those holding a US STC will comply with AASR, therefore, no additional technical work is required to comply with the EASA damage tolerance requirements for repairs and modifications up to the LoV.

Retroactive consideration of WFD up to the LoV has not been mandated for STCs for the following reasons:

1. Harmonisation: FAR Part 26 requires TCHs to address future changes (as applicants for amended TCs). There are no similar requirements for STC applicants.
2. Changed product rule: Part 21.101 will require a new certification basis including CS-25 Amdt X (LoV/WFD) for significant changes. This would address changes that can influence WFD, such as freight door conversions, winglets, and significant weight increases.
3. DT for repairs and changes — inspections in place: The requirement for DTI for all existing repairs and changes means that all repairs and changes will be inspected as necessary, significantly reducing the risk of WFD developing. Furthermore, many repairs and changes take into account MSD/MED cracking scenarios and the risk of missing cracking during inspection on small area change/repair is low compared to large areas of OEM structure, e.g. lap joints.
4. Implementation time of changes: Many repairs and STCs that physically change the structure are put in place later in the aircraft life compared to TCH changes in production. This tends to reduce the risk of WFD developing in the repair or changed structure during the operational life of the aircraft.

Potential cost to operators

The rules that are developed will impact continuing airworthiness and potentially the life of the affected aircraft. Examples of the impact on continuing airworthiness are:

1. Changes to maintenance programmes including supplementary inspections and the need to implement specific modifications. The timescales provided for implementation of the ageing aircraft programme are intended to minimise the impact on the general schedules for maintenance of the fleet;
2. Review of existing repairs and implement possible corrective actions: this can range from additional inspections to replacement of the repair; and
3. Training.

One of the difficulties in providing an accurate picture is that the rule asks for developing LoV that is not fully known yet and whose consequences are therefore not yet fully known either (e.g. amount of maintenance instructions). We assume

that the LoV that will be established will not lead to significant aircraft retirement. We also do not expect that the LoV alone will set the economic life of an aircraft.

For larger and younger fleets, overall the implementation of these maintenance programmes in a timely manner and in the long term may bring safety and economic benefits to some operators because the risk of the need to react to unplanned maintenance input to correct airworthiness urgent issues would be minimised.

Concerning damage tolerance, one benefit of the rule is that the development of inspections will generally be done by the design approval holders who are in the best position to identify fatigue-critical structures and appropriate methods and frequency of inspections. This will result in a decrease of the overall cost since it is assumed that the work will be done more efficiently by the manufacturers who have access to all the data.

Summary of economics impacts

Option 0	Voluntary compliance: Cost will depend on the number of stakeholders implementing the AMC and could be similar to option 1 (if all stakeholders choose to use the AMC 20-20).
Option 1	<p>Potential cost would be relevant for stakeholders which have not implemented AMC 20-20 from option 0.</p> <p>This is the most costly option in the short term. However, burden can be alleviated by:</p> <ul style="list-style-type: none"> — Determining the appropriate LoV and by the careful planning of the maintenance tasks. — A large proportion of the fleet had to show compliance already with the FAA requirements. — The proposal to introduce exemption criteria. Applicants and DAHs should submit their proposals for exemptions within the NPA public consultation period. The impact of option 1 would be minimised if stakeholders meet the criteria for exclusion. <p>Additionally, option 1 will allow for the following:</p> <ul style="list-style-type: none"> — Mitigation of the safety risk; therefore, the extensive cost of incidents/accidents. — Extension of the economic life of the airplane with corresponding revenues from that additional economic life. — Near elimination of emergency Airworthiness Directives pertaining to ageing aircraft which significantly reduces the downtime associated with urgent unscheduled maintenance. — It allows for transparency and openness.

5.5. Proportionality issues

As STCHs are usually small companies, the proposed rules may create a burden on them. The number of STCs that would need to be addressed is generally believed to be proportionate to the size and capability of the company.

5.6. Impact on regulatory coordination and harmonisation

FAA has already adopted regulations addressing ageing aircraft structures. TCCA is also developing comparable rules. A close cooperation on ageing aircraft issues has been established for several years with FAA, TCCA, and ANAC.

Option 0	May lead to sporadic development of many of the technical elements of the ageing aircraft structural integrity programme and would not ensure consistent application of those principles to the existing fleet.
Option 1	<p>Would lead to harmonisation being achieved to a large extent. However, there are remaining differences compared with the FAA rules.</p> <p>Adopting the rules ensures, however, compatibility with ICAO Annex 8.</p>

6. Conclusion and preferred option

(a) Comparison of the positive and negative impacts for each option:

Option 0	The actual impacts would depend on how many of the affected stakeholders choose to implement the principles of AMC 20-20 for their existing fleet. The implementation would not ensure consistent application to the fleet.
Option 1	<p>Would provide a framework to proactively address ageing aircraft safety issues.</p> <p>Potential cost would be relevant for stakeholders which have not implemented AMC 20-20 from option 0.</p> <p>This is the most costly option in the short term, as it mandates the development and implementation of maintenance actions that might not otherwise be undertaken in a timely manner.</p> <p>The initial cost incurred may be, however, offset by the consequences (including financial) of an incident or accident which may otherwise be avoided by implementing this option.</p> <p>This option may contribute to significantly reduce the downtime associated with the urgent unscheduled maintenance or Airworthiness Directives.</p> <p>Burden can be alleviated by an appropriate LoV and proper scheduling of the maintenance tasks. Additional alleviation comes from that part of the fleet that is already compliant with the similar FAA requirements for ageing aircraft.</p> <p>Option 1 allows for transparency and openness and may extend the economic life of the airplane.</p> <p>This option would also achieve harmonisation to a large extent with FAA and TCCA (however, not a complete harmonisation) and compatibility with the relevant ICAO requirement.</p>

(b) Final assessment and recommendation of a preferred option.

Option 1 has been chosen by the Agency despite its potentially higher cost, since it is proactively addressing ageing aircraft safety issues and achieves to a large extent, although not completely, harmonisation with FAA and TCCA.

B. Draft Opinion(s) and/or Decision(s)

The text of the amendment is arranged to show deleted text, new text, or new paragraph as shown below:

1. deleted text is shown with a strike through: ~~deleted~~
2. new text is highlighted with grey shading: **new**
3. ... indicates that remaining text is unchanged in front of or following the reflected amendment.

I. Draft Opinion Part-21

21.A.21 Issue of a type certificate

The applicant shall be entitled to have a product type certificate issued by the Agency after:

(c) it is shown that:

...

5. The type certificate applicant complies with the requirements for type certificate holders of Annex 1 ('Part-26') to Regulation (EU) No .../... on additional airworthiness requirements for operations.

21.A.101 Designation of applicable certification specifications and environmental specification requirements

...

(f) If an applicant chooses to comply with a certification specification of an amendment to the airworthiness codes that is effective after the filing for the application for a change to a type, the applicant shall also comply with any other certification specification that the Agency finds it directly related.

(g) An applicant for a change to a type certificate shall comply with the requirements for applicants for a change to a type certificate of Annex 1 ('Part-26') to Regulation (EU) No .../... on additional airworthiness requirements for operations.

21.A.433 Repair design

(a) The applicant for approval of a repair design shall:

1. demonstrate compliance with the type certification basis and environmental protection requirements incorporated by reference in the type certificate or supplemental type certificate or APU ETSO authorisation, as applicable, or those in effect on the date of application (for repair design approval), plus any amendments to those certification specifications or special conditions the Agency finds necessary to establish a level of safety equal to that established by the type certification basis incorporated by reference in the type certificate, supplemental type certificate or APU ETSO authorisation, plus the requirements for applicants for approval of a repair design of Annex 1 ('Part-26') to Regulation (EU) No .../... on additional airworthiness requirements for operations.

2. submit all necessary substantiation data, when requested by the Agency;

...

II. Draft Opinion Part-26

...

Article 1

Scope

This Regulation lays down common additional airworthiness requirements to support the continued airworthiness and safety improvements of:

...

3. Aircraft, changes and repairs designed by an organisation for which the Agency ensures safety oversight.

Article 2

Definitions

For the purposes of this Regulation, the following definitions shall apply:

1. Emergency exits:
 - (a) 'Type A emergency exit' is a floor level exit with a rectangular opening of not less than 1.07 m wide by 1.83 m high with corner radii not greater than one sixth of the width of the exit.

...

7. 'Limit of validity' (LoV) is the number of total accumulated flight cycles or flight hours or both, for which it has been demonstrated that widespread fatigue damage is unlikely to occur in the aeroplane structure; and that the inspections and other maintenance actions and procedures resulting from this demonstration and other elements of the fatigue and damage tolerance evaluation are sufficient to prevent catastrophic failure of the aeroplane structure. The LoV is commonly known as the limit of validity of the engineering data that support the maintenance programme.
8. 'Airworthiness limitation section' (ALS) is a section in the instructions for continuing airworthiness that contains airworthiness limitations that set forth each mandatory replacement time, inspection interval and related inspection procedure.
9. 'Widespread fatigue damage' (WFD) in a structure is the simultaneous presence of cracks at multiple structural details that are of sufficient size and density whereby the structure will no longer meet the applicable residual strength requirements.
10. 'Corrosion prevention and control programme' (CPCP) is a systematic approach to prevent and to control corrosion in the aircraft's primary structure consisting of a basic corrosion inspection task, task areas, defined corrosion levels, and compliance times (implementation thresholds and repeat intervals).
11. 'Damage tolerance evaluation' (DTE) is a process that leads to the determination of maintenance actions necessary to detect or preclude fatigue cracking that could contribute to a catastrophic failure. As applied to repairs and modifications, DTE includes the evaluation of the repair or modification and the fatigue-critical structure affected by the repair or modification.
12. 'Damage tolerance inspections' (DTI) are the inspections developed as a result of a DTE. A DTI includes the areas to be inspected, the inspection method, the inspection procedures (including acceptance and rejection criteria), the threshold, and any repetitive intervals associated with those inspections. DTIs

may specify a time limit when a repair or modification needs to be replaced or modified.

13. 'Repair evaluation guideline' (REG) is a process to establish damage tolerance inspections for repairs that affect fatigue-critical structure to ensure the continued structural integrity of all relevant repaired and adjacent structure.
14. 'Published repair data' are instructions for accomplishing repairs which are published for general use in structural repair manuals and Service Bulletins (or equivalent types of documents).
15. 'Existing design changes or repairs' are changes and repairs which are approved before the entry into force of this rule.
16. 'Future design changes and repairs' are changes and repairs which are approved after the entry into force of this rule.

Article 3

Additional airworthiness requirements for operations

Aircraft registered in a Member State or registered in a third country and used by an operator established or residing in the European Union shall comply with the relevant provisions of Annex I to this Regulation (Part-26).

The design of an aircraft, changes or repairs approved by the Agency or deemed to have been issued in accordance with Commission Regulation (EU) No 748/2012, shall comply with the provisions of Annex I to this Regulation (Part-26).

ANNEX I

PART-26

Additional airworthiness requirements for operations

Subpart A – General provisions

26.10 Competent authority

- (a) For the purpose of this Part, the competent authority to which compliance with the requirements needs to be demonstrated by operators shall be the authority designated by the Member State in which the operator has its principal place of business.
- (b) For the purpose of this Part, the competent authority to which compliance with the requirements needs to be demonstrated by holders of and applicants for type certificate, restricted type certificate, supplemental type certificate and repair design approvals shall be the Agency.

26.30 Demonstration of compliance

...

- (b) Operators, holders of and applicants for type certificate, restricted type certificate, supplemental type certificate and repair design approval may demonstrate compliance with the requirements of this Part by complying with:

...

Subpart B – Large aeroplanes

...

26.300 Continuing Structural Integrity for ageing aircraft structures – General requirements

The holder of a TC or restricted TC of a turbine-powered large aeroplanes certified after 1 January 1958, except as stated in Appendix I to Part-26, and the applicant for a TC or restricted TC for a turbine-powered large aeroplane, shall comply with the following:

- (a) Unless previously accomplished, create an ALS within the existing instructions for continuing airworthiness.
- (b) Unless previously accomplished, perform a fatigue and damage tolerance evaluation of the aeroplane structure and establish associated inspections and other procedures that ensure freedom from catastrophic failure due to fatigue throughout the operational life of the aircraft. Include directly or by reference these inspections and other procedures in the ALS.
- (c) For aeroplanes with a maximum take-off weight (MTOW) above 34 019 kg (75 000 lbs), establish an limit of validity (LoV) of the engineering data that supports the structural maintenance programme and include this LoV in the ALS.

The aircraft structural configurations to be evaluated include:

- (1) all model variations and derivatives approved under the type certificate as of the entry into force of this rule;
- (2) all structural changes and replacements to the aircraft structural configurations specified in point (c)(1), mandated by airworthiness directives as of the entry into force of this rule; and
- (d) Identify existing maintenance actions and develop new maintenance actions, upon which the LoV depends.
- (e) Unless previously accomplished, establish a baseline CPCP for approval by the Agency.
- (f) Establish a process that ensures that unsafe levels of fatigue cracking will be precluded in service. This process must include:
 - (1) periodic monitoring of operational usage with comparison to design assumptions; and
 - (2) a periodic assessment of the need for mandatory changes in cases where inspection alone is not reliable enough to ensure that unsafe levels of cracking are precluded.
- (g) Identify the fatigue-critical baseline structure and principal structural elements (PSEs) for all aircraft models and derivatives in the type certificate. Incorporate or reference the list in the instructions for continuing airworthiness and upon the approval of the list make it available to operators and persons required to comply with Part 26.330, 360 and 370.
- (h) Compliance times
 - (1) Develop the ALS contents required by point (b) and submit these to the Agency for approval within 24 months from the entry into force of this rule, except that applicants for TC must obtain approval prior to the issuing of the TC.

- (2) Develop the LoV and ALS amendment required by point (c) and submit them to the Agency for approval not later than it is provided in (h)(2)(i), (ii) or (iii).
 - (i) 18 months from the entry into force of the rule, for aircraft certified according to JAR 25.571 Change 7 or FAR 25.571 Amdt 45 or earlier amendments;
 - (ii) The later of 60 months from the entry into force of the rule or when the TC is issued or the date specified in the plan approved for completion of the full-scale fatigue testing and demonstrating that widespread fatigue damage will not occur in the large aeroplane structure, for aircraft certified in Europe or in the USA according to FAR 25.571 Amdt 96 or later amendments;
 - (iii) 48 months from the entry into force of the rule for all other aircraft.
- (3) Submit the actions established according to point (d) to the Agency for approval, according to a schedule agreed with the Agency. The schedule must be submitted together with the LoV according to the compliance time of point (h)(2).
- (4) If the baseline CPCP required by point (e) is not currently approved by the Agency and available to operators, submit one to the Agency for approval within 24 months from the entry into force of this rule or prior to the issuing of the TC, if later.
- (5) Submit the process required by point (f) to the Agency within 24 months from the entry into force of this rule or prior to the TC issue, if later. Implement the process within 6 months after the approval by the Agency.
- (6) Within 6 months from the entry into force of this rule or prior to the TC issue if later, submit to the Agency for approval a list of the structure identified under point (g).

26.310 Design changes impact on the LoV

The holder of a TC or restricted TC of a turbine-powered large aeroplanes certified after 1 January 1958 with a maximum take-off weight (MTOW) above 34 019 kg (75 000 lbs), except as stated in Appendix I to Part-26, shall comply with the following:

Perform a widespread fatigue damage (WFD) evaluation of all type design changes approved after the entry into force of this rule and assess the impact of each design change on the LoV and existing maintenance actions established in accordance with Part 26.300.

Develop all new maintenance actions necessary to preclude WFD up to the LoV and submit them for the Agency's approval not later than:

- (1) 60 months from the entry into force of this rule; or
- (2) the design change approval date; or
- (3) the date specified in the plan approved for completion of the full-scale fatigue testing and demonstrating that widespread fatigue damage will not occur in the aeroplane structure.

26.320 Damage Tolerance data for existing repairs, existing changes, and existing repairs to changes to Fatigue-Critical Structure

The holder of a TC or restricted TC of turbine-powered large aeroplanes certified after 1 January 1958 and, with 30 or more passengers or that have a payload of 3401,9 kg (7 500 lbs) or more, except as stated in Appendix I to Part-26, shall comply with the following:

- (a) List of Fatigue-Critical Modified Structure (FCMS)
 - (1) Review existing design changes (modifications) and identify all changes that affect fatigue-critical baseline structure identified under point (g) of Part 26.300 or introduced fatigue-critical structure;
 - (2) For each change identified under point (a)(1), identify any associated fatigue-critical structure that is not already included in the fatigue-critical baseline structure list; and
 - (3) Submit to the Agency for approval a list of the structure identified under point (a)(2) and, upon approval, make the lists available to operators and persons required to comply with Part 26.330, 26.360, 26.370.
- (b) Existing published repair data
 - (1) Review the repair data and identify each repair specified in the data that affects fatigue-critical baseline structure and fatigue-critical modified structure identified under point (f) of Part 26.300 and point (a)(1);
 - (2) Unless previously accomplished, perform a Damage Tolerance Evaluation and develop the Damage Tolerance Inspection (DTI) for each repair identified under point (b)(1).
- (c) Develop Repair Evaluation Guidelines (REGs) that:
 - (1) establish a process for conducting surveys of affected aircraft that will enable identification and documentation of all existing repairs that affect fatigue-critical structure identified under point (g) of Part 26.300 and point (a)(1);
 - (2) establish a process that will enable operators to obtain the DTI for repairs identified under point (c)(1); and
 - (3) establish an implementation schedule for repairs addressed by the repair evaluation guideline. The implementation schedule must identify times when actions must be taken, defined in terms of aircraft flight hours, flight cycles, or both.
- (d) For existing changes identified under point (a)(1), perform a damage tolerance evaluation and develop the damage tolerance inspections for the modification and fatigue-critical baseline structure that is affected by the change.
- (e) Compliance times

The following data must be submitted to the Agency for review and approval by the specified compliance time:

 - (1) the list of fatigue-critical modified structure required by point (a) must be submitted within 12 months from the entry into force of this rule;
 - (2) for published repair data that are current as of the entry into force of this rule, the damage tolerance data required by point (b)(2) must be submitted within 18 months from the entry into force of this rule;

- (3) the repair evaluation guidelines required by point (c) must be submitted within 24 months from the entry into force of this rule; and
- (4) for changes developed and approved before the entry into force of this rule, the damage tolerance data required by point (d) must be submitted within 18 months from the entry into force of this rule.

26.330 DT data for existing STCs and repairs to STCs

The holder of an STC or the holder of a major design change that has been deemed approved in accordance with Article 4 of Regulation (EU) No 748/2012, for large aeroplanes certified after 1 January 1958 and with 30 or more passengers or that have a payload of 3401,9 kg (7500 lbs) or more, except as stated in Appendix I to Part-26, shall comply with the following:

- (a) For existing major structural changes and published repairs to changes:
 - (1) review the changes and repairs and identify those that affect fatigue-critical structure identified under point (g) of Part 26.300 or point (a)(2) of Part 26.320 or that introduce new fatigue-critical structure; and
 - (2) develop and submit to the Agency for review and approval a list of the changes and structures identified under point (a)(1) and upon approval make this list available to persons required to comply with Part 26.360 and 26.370.
- (b) For existing changes and published repairs identified under point (a)(1), unless previously accomplished, perform a damage tolerance evaluation and develop the damage tolerance inspection for the change and repairs and the fatigue-critical structure that is affected by the change.
- (c) Compliance times
 - (1) The list of changes and fatigue-critical structure required by point (a)(2) must be submitted within 12 months from the entry into force of this rule.
 - (2) Submit, to the Agency, for review and approval, the damage tolerance data required by point (b), within 24 months from the entry into force of this rule.

26.350 Extension of an LoV

- (a) The applicant for an LoV extension for a large aeroplane shall comply with the following:
 - (1) A fatigue and damage tolerance evaluation of the following structural configurations must be performed for:
 - (i) all model variations and derivatives approved under the type certificate for which approval for an extension of the LoV is sought; and
 - (ii) all major structural changes to and replacements of the aeroplane structural configurations specified in point (a)(1)(i), mandated by airworthiness directive, up to the date of approval of the extended LoV.
 - (2) The evaluation must include consideration of WFD and establish the DTI and any necessary maintenance actions required to preclude catastrophic failure up to the proposed LoV. The inspections and other

maintenance actions and procedures resulting from this evaluation must be included in a revision to the ALS or a supplement to the ALS as appropriate. The ALS must address the need for all design changes and repairs on an aircraft to be substantiated before the extended LoV can be adopted in the structural maintenance programme for that aircraft.

- (3) The ALS revision or supplement must be submitted to the Agency for approval.
- (b) The applicant for approval of a change or a repair which affects the fatigue-critical structure of a large aeroplane with an approved extension to an LoV, and the holder of an approval of a change or repair which affects the fatigue-critical structure of a large aeroplane, supporting an operator wishing to implement an extended LoV, shall comply with the following:
- (1) A Fatigue and Damage Tolerance Evaluation of the changed or repaired structure for which they hold the approval or application for the approval thereof, and of any other structure that is affected by that change or repair, must be performed.
 - (2) The evaluation must include consideration of WFD and establish the DTI and any necessary maintenance actions required to preclude catastrophic failure up to the proposed LoV.
 - (3) The DTI and any necessary maintenance actions established according to point b(2) must be submitted to the Agency for approval.

26.360 Fatigue and Damage Tolerance Evaluation of future repairs and changes

The applicant for a repair or change approval to large aeroplanes, which is approved after the entry into force of this rule, shall comply with the following:

- (a) For all repairs and changes that affect or include fatigue-critical structure, perform a damage tolerance evaluation and develop the inspections and other procedures that will preclude catastrophic failure due to fatigue throughout the operational life of the aeroplane. Identify any new principal structural elements and fatigue-critical structure introduced or created by the change and include these new principal structural elements and fatigue-critical structure in the instructions for continuing airworthiness.
- (b) Compliance times
- (1) For applications for changes received after the entry into force of this rule, the data required by point (a) must be submitted to the Agency before approval of the change.
 - (2) For applications for changes received prior to the entry into force of this rule, and for which damage tolerance evaluation is not required by the applicable certification basis, the data required by point (a) must be submitted to the Agency within 12 months from the entry into force of the rule, or before the approval of the change, if later.
 - (3) For repairs, a damage tolerance evaluation defining thresholds for maintenance actions that allow continued safe operation must be submitted to the Agency within 12 months after the initial repair approval, except as provided in 26.360 b(4).
 - (4) If prior to release into service an evaluation has been submitted that supports the approval of a temporary limitation allowing a period of safe

operation, the approval of the data required under 26.360 b(3) must be accomplished prior to the expiry of the temporary limitation.

- (5) The approval of the inspections and other procedures required by 26.360(a) must be granted before the first approved inspection threshold is reached.

26.370 Maintenance programme

The operator/owner of large aeroplanes shall comply with the following:

- (a) Revise the maintenance programme to include:
 - (1) Applicable inspections or maintenance procedures issued by the TCH in compliance with Part 26.300(b), (c) and (d).
 - (2) A CPCP that takes into account the baseline CPCP issued by the TCH in compliance with Part 26.300(e).
 - (3) The REG and associated DTI issued by the TCH in compliance with Part 26.320 for the repairs embodied to the aircraft.
 - (4) The DTI issued by the holders of an STC or a major design change in compliance with Part 26.320 and 26.330.
 - (5) For existing repairs that are not addressed by the operator's implementation of the REG and STCs and major changes that affect fatigue-critical structure, for which DTI does not exist and that are embodied on an aircraft of a type subject to Part 26.320, a procedure to show how approved damage tolerance inspection data will be obtained and used to address the potential adverse effects of repairs and modifications to fatigue-critical structure.
- (b) Prior to incorporating an EASA-approved extended LoV into a maintenance programme, an operator shall:
 - (1) Ensure that all installed repairs and modifications have been subject to a fatigue and damage tolerance evaluation, including consideration of WFD up to the proposed LoV, according to Part 26.350.
 - (2) Amend the aircraft maintenance programme required by M.A.302 to incorporate the approved DTI and other maintenance actions established as a result of these evaluations and any other associated ALS amendments.
- (c) Compliance times
 - (1) Complete the actions required by point (a)(1) within 12 months from the approval by the Agency of each applicable revision of the ALS and any other applicable maintenance actions approved by the Agency in compliance with Part 26.300(d).
 - (2) Complete the actions required by point (a)(2) within 12 months from the approval by the Agency of the baseline CPCP or within 12 months from the day of entry into force of this Regulation, whichever occurs later.
 - (3) Complete the actions required by points (a)(3) and (a)(5) within 12 months from the approval by the Agency of the applicable REG.
 - (4) Complete the actions required by point (a)(4) within 12 months from the approval by the Agency of the applicable DTI.

Appendix I to Part-26

The following aeroplanes are excluded from compliance with Part 26.3XX.

[To be determined; see paragraph 10 of the Explanatory Note]

III. Draft Decision CS-26

...

CS 26.300 Continuing Structural Integrity for ageing aircraft structures – General requirements – TCHs, holder of restricted TC, and applicants for TC or restricted TC (see AMC 20-20)

Compliance with the fatigue and damage tolerance evaluation required by Part 26.300 point (b) is demonstrated by complying with Amdt X of CS 25.571 or with the applicable following points (a) or (b):

- (a) For aircraft structure certified prior to JAR 25.571 Change 7 or FAR 25.571 Amdt 45 or equivalent, a fatigue and damage tolerance evaluation according to JAR 25.571 Change 7 or equivalent exists and either a Supplemental Structural Inspection Document (SSID) exists and is included in the ALS for approval, or a reference provided in the ALS to an existing approved SSID or equivalent document. In both cases, the documentation includes the time in flight cycles, flight hours or other relevant measure by which the actions within the SSID are implemented.
- (b) For aircraft structure certified according to JAR 25.571 Change 7 or FAR 25.571 Amdt 45 or equivalent or later amendments: the inspections or other procedures resulting from the damage tolerance evaluation required by that certification basis are included in the ALS.

Compliance with Part 26.300 points (c) and (d) is demonstrated by complying with Amdt X of CS 25.571 or by fulfilling the provisions of the following points (c) and (d):

- (c) The evaluation supporting the LoV required by Part 26.300 point (c) includes a substantiation that widespread fatigue damage is unlikely to occur in the aeroplane structure, and that the inspections and other maintenance actions and procedures resulting from this evaluation are sufficient to prevent catastrophic failure of the aeroplane structure up to the LoV (see AMC 20-20).

The ALS includes the LoV of each aircraft structural configuration required by Part 26.300 points (c) and (d) and each LoV is supported by test evidence, analysis and, if available, service experience and teardown inspection results of high time aircraft of similar structural design, accounting for differences in operating conditions and procedures.

- (d) A list is established of all maintenance actions upon which the LoV is dependant. The list identifies existing mandated actions, existing actions that have not been mandated at the entry into force of the rule and any new maintenance actions required. A schedule for development and submission of the maintenance actions to the Agency, as required by Part 26.300 point (h) (3), is agreed by the Agency prior to approval of the LoV.

The new maintenance actions are established and together with the existing non-mandated actions are submitted to the Agency for approval according to the schedule agreed by the Agency.

Compliance with Part 26.300 point (e) is demonstrated by complying with Amdt X of CS 25.571 or by complying with the following points (e) or (f):

- (e) A baseline programme is established according to AMC 20-20 and it includes a statement that requires the operator to control corrosion to Level 1 or better and is submitted to the Agency.
- (f) A baseline programme already exists for the type that is either approved by the Agency through the Maintenance Review Board (MRB) Industry Steering Committee (ISC) using existing procedures for EASA Maintenance Review Board Report (MRBR) approval or through an existing EASA Airworthiness Directive.

CS 26.310 Design changes – Impact on the LoV – TCHs or holders of restricted TC

Compliance with Part 26.310 is demonstrated through compliance with Amdt X of CS 25.571 or with the following:

- (a) WFD evaluations required by Part 26.310 substantiate freedom from WFD up to the existing LoV or a new reduced LoV approved by the Agency (see AMC 20-20); and
- (b) The extent of the test evidence required in support of the WFD evaluation is agreed by the Agency; and
- (c) Inspections and other maintenance actions upon which the LoV is dependent are established according to the schedule required by Part 26.310.

CS 26.320 Damage Tolerance data for existing repairs, existing changes, and existing repairs to changes to Fatigue-Critical Structure – TCHs or holders of restricted TC (see AMC 20-20)

Compliance with the fatigue and damage tolerance evaluation required by Part 26.320 points (b) and (d), and compliance with any damage tolerance evaluation arising from compliance with Part 26.320(c) is demonstrated by complying with Amdt X of CS 25.571 or with the following:

- (a) The fatigue and damage tolerance evaluation is in accordance with the damage tolerance requirements of the applicable certification basis, except as provided in (b).
- (b) For aircraft certified to a requirement earlier than the JAR-25 Amdt 7, the fatigue and damage tolerance evaluation is in accordance with the JAR-25 Amdt 7 or an equivalent or later requirement, except that residual strength loads may be based upon the fail-safe load cases of the original certification basis.

CS 26.330 Damage Tolerance data for STCs and repairs to STCs – STCHs and holders of major design change approvals approved in accordance with Article 4 of Regulation (EU) No 748/2012 (see AMC 20-20)

Compliance with the fatigue and damage tolerance evaluation required by Part 26.330 point (b) is demonstrated by complying with Amdt X of CS 25.571 or with the following:

- (a) The fatigue and damage tolerance evaluation is accomplished in accordance with the damage tolerance requirements of the applicable certification basis, except as provided in (b).

- (b) For aircraft certified to a requirement earlier than the JAR-25 Amdt 7, the fatigue and damage tolerance evaluation is accomplished in accordance with the JAR-25 Amdt 7 or an equivalent or later requirement, except that residual strength loads may be based upon the fail-safe load cases of the original certification basis.

CS 26.350 Extension of an LoV – All design approvals holders and applicants for design change approval (see AMC 20-20)

Compliance with Part 26.350 is demonstrated by complying with Amdt X of CS-25 or with the following:

- (a) The evaluation for the extension of the LoV includes a demonstration that widespread fatigue damage is unlikely to occur in the aeroplane structure addressed under Part 26.350(a) and (b), and that the inspections and other maintenance actions and procedures resulting from this evaluation are sufficient to prevent catastrophic failure of the aeroplane structure up to the extended LoV. The LoV of each aircraft structural configuration is supported by sufficient test evidence, analysis and, if available, service experience and teardown inspection results of high time aircraft of similar structural design, accounting for differences in operating conditions and procedures.
- (b) The ALS revision or supplement includes clear instructions to the operator, declaring that in order for the LoV to be approved in the structural maintenance programme under Part-M requirements, the operator is responsible for ensuring that all installed repairs and modifications affecting fatigue-critical structure have been subject to a fatigue and damage tolerance evaluation, including consideration of WFD, and are supported by maintenance actions approved by the Agency and established in accordance with point (c).
- (c) The remainder of the fatigue and damage tolerance evaluation is in accordance with the damage tolerance requirements of the applicable certification basis, except as provided in (d).
- (d) For aircraft certified to a requirement earlier than the JAR-25 Amdt 7, the fatigue and damage tolerance evaluation is in accordance with the JAR-25 Amdt 7 or an equivalent or later requirement, except that residual strength loads may be based upon the fail-safe load cases of the original certification basis.

CS 26.360 Fatigue and Damage Tolerance Evaluation of future repairs and changes – Applicants for design change and repair approvals including STCs (see AMC 20-20)

Compliance with Part 26.360(a) is demonstrated by complying with Amdt X of CS-25 or with the following:

- (a) The fatigue and damage tolerance evaluation is in accordance with the damage tolerance requirements of the applicable certification basis, except as provided in (b).
- (b) For aircraft certified to a requirement earlier than the JAR-25 Amdt 7, unless a later requirement is applicable according to Part 21.101, the fatigue and damage tolerance evaluation is in accordance with the JAR-25 Amdt 7 or equivalent, except that residual strength loads may be based upon the fail-safe load cases of the original certification basis.

Compliance with Part 26.360(b)(3), (b)(4) and (b)(5) for a repaired aircraft released into service before the fatigue and damage tolerance evaluation has been completed is demonstrated by complying with the following:

- (c) The evaluation and associated maintenance data required by Part 26.300(a) is submitted to the Agency:
 - (1) within 12 months from the initial approval of the repair design; or
 - (2) incrementally, according to the approval process for new repairs as provided for in AMC 20-20, Appendix 3, Annex 1.

CS 26.370 Maintenance programme – Operators and organisations responsible for maintenance programmes for large aeroplanes under Part-M (see AMC 20-20)

Compliance with Part 26.370(a)(3), (a)(4) and (a)(5) is demonstrated by complying with the following:

- (a) A review has been conducted by the operator or the Continuing Airworthiness Maintenance Organisation (CAMO) of the applicable documents supplied by TCH and STC holders in compliance with Part 26.300, 26.320, and 26.330.
- (b) Modifications that exist in the aircraft that affect or include fatigue-critical structure have been identified and listed in a report held by the operator or the Continuing Airworthiness Maintenance Organisation.
- (c) A plan has been established to address additional DT data for modifications and repairs not addressed by the TCH or STC holder's documents that shows how the additional data will be obtained by the operator and approved by the Agency.
- (d) The necessary actions included in the approved data (REGs and currently available inspection requirements for repairs and modifications) and the plan established under (c) have been incorporated into the maintenance programme for approval by the competent authority.

Compliance with Part 26.370(b) is demonstrated by complying with the following:

- (e) The operator holds evidence from the repair or design approval holder that the repair or modification data for any repair or modification installed on the aircraft is in compliance with Part 26.350(b).
- (f) All applicable DTI and other maintenance actions have been incorporated in the maintenance programme.

IV. Draft Decision CS-25

CS 25.571 Damage tolerance and fatigue evaluation of structure

(a) General

An evaluation of the strength, detail design, and fabrication must show that catastrophic failure due to fatigue, **environmental corrosion** or accidental damage, will be avoided throughout the operational life of the aeroplane. This evaluation must be conducted in accordance with the provisions of subparagraph (b) ~~and (e)~~ of this paragraph, except as specified in subparagraph ~~(e)~~ **(a)(4)** of this paragraph, for each part of the structure that could contribute to a catastrophic failure. ~~(such as wing, empennage, control surfaces and their systems, the fuselage, engine mounting, landing gear, and their related primary attachment). (See AMC 25.571 (a) (b) and (e)).~~ Additionally, a discrete source damage evaluation must be conducted in accordance with subparagraph (e) of this paragraph and for turbine engine-powered aeroplanes, those parts that could contribute to a catastrophic failure must also be evaluated ~~under~~ in accordance with subparagraph (d) of this paragraph. In addition, the following apply:

- (1) ~~Each evaluation required by this paragraph~~ **The evaluations of subparagraphs (b) and (c) must include:**
 - (i) the **determination of** typical loading spectra, temperatures, and humidity expected in service;
 - (ii) the identification of principal structural elements and detail design points, the failure of which could ~~cause~~ **contribute to** a catastrophic failure of the aeroplane; and
 - (iii) an analysis, supported by test evidence, of the principal structural elements and detail design points identified in subparagraph (a)(1)(ii) of this paragraph .
- (2) The service history of aeroplanes of similar structural design, taking due account of differences in operating conditions and procedures, may be used in the evaluations required by this paragraph.
- (3) Based on the evaluations required by this paragraph, inspections or other procedures must be established, as necessary, to prevent catastrophic failure, and must be included in the ALS of the ICA required by CS 25.1529.

The LoV of the engineering data that supports the structural maintenance programme, stated as a number of total accumulated flight cycles or flight hours or both, established by this paragraph must also be included in the ALS of the ICA required by CS 25.1529.

- (4) **If the results of the evaluation required by subparagraph (b) show that damage tolerance-based inspections are impractical, then an evaluation must be performed in accordance with the provisions of subparagraph (c).**

If the results of the evaluation show that damage tolerance-based inspections are practical, then inspection thresholds must be established for all PSEs and detail design points. For the following types of structure, the threshold must be established based on crack growth analyses and/or tests, assuming the structure contains an initial flaw of the maximum probable size that could exist as a result of manufacturing or service-induced damage:

- (i) single load path structure; and
- (ii) multiple load path 'fail-safe' structure and crack arrest 'fail-safe' structure, where it cannot be demonstrated that the resulting load path failure or partial failure (including arrested cracks) will be detected and repaired during normal maintenance, inspection, or operation of an aeroplane prior to failure of the remaining structure.

(5) Inspection programmes for environmental damage and service-induced accidental damage must be established to protect the structure against catastrophic failure. In addition, the ALS must include a statement that requires the operator to include a CPCP in their maintenance programme that will ensure that corrosion is controlled to Level 1 or better.

(b) **Fatigue and Damage Tolerance (~~fail-safe~~) Evaluation**

The evaluation must include a determination of the probable locations and all modes of damage due to fatigue, environmental (e.g. corrosion), manufacturing defects or accidental damage. ~~The determination must be by analysis~~ Repeated load and static analyses supported by test evidence and (if available) service experience must be incorporated in the evaluation. Damage at multiple sites due to prior fatigue exposure (including special consideration of widespread fatigue damage) must be included in the evaluation where the design is such that this type of damage could occur. An LoV must be established that is not more than the period of time, stated as a number of total accumulated flight cycles or flight hours or both, for which it has been demonstrated:

- (1) by full-scale fatigue test evidence that widespread fatigue damage is unlikely to occur in the aeroplane structure;
- (2) that the inspections and other maintenance actions and procedures resulting from the fatigue and damage tolerance evaluation and provided in the ALS and ICA are sufficient to prevent catastrophic failure of the aeroplane structure.

The type certificate may be issued prior to completion of the full-scale fatigue testing, provided that the Agency has approved a plan for completing the required tests and analyses, and that at least one calendar year of safe operation has been substantiated at the time of type certification. In addition, the ALS must specify an interim limitation restricting aircraft operation to not more than half the number of the flight cycles or flight hours accumulated on the fatigue test article, until such testing is completed and freedom from widespread fatigue damage has been established.

The extent of damage for residual strength evaluation at any time within the operational life of the aeroplane must be consistent with the initial detectability and subsequent growth under repeated loads.

The residual strength evaluation must show that the remaining structure is able to withstand loads (considered as static ultimate loads) corresponding to the following conditions:

- (1) The limit symmetrical manoeuvring conditions specified in CS 25.331 at all speeds up to V_C and in CS 25.345.
- (2) The limit gust conditions specified in CS 25.341 at the specified speeds up to V_C and in CS 25.345.

- (3) The limit rolling conditions specified in CS 25.349 and the limit unsymmetrical conditions specified in CS 25.367 and 25.427(a) through (c), at speeds up to V_C .
- (4) The limit yaw manoeuvring conditions specified in CS 25.351 at the specified speeds up to V_C .
- (5) For pressurised cabins, the following conditions:
 - (i) The normal operating differential pressure combined with the expected external aerodynamic pressures applied simultaneously with the flight loading conditions specified in subparagraphs (b)(1) to (b)(4) of this paragraph if they have a significant effect.
 - (ii) The maximum normal operating differential pressure multiplied by a factor of 1.15, combined with the expected external aerodynamic pressures during 1g level flight, omitting other loads.
- (6) For landing gear and other affected airframe structure, the limit ground loading conditions specified in CS 25.473, 25.491, and 25.493.

If significant changes in structural stiffness or geometry, or both, follow from a structural failure, or partial failure, the effect on damage tolerance must be further evaluated ~~investigated. (See AMC 25.571 (a), (b) and (e).)~~

(c) Fatigue (safe-life) evaluation

Compliance with the damage tolerance requirements of subparagraph (b) of this paragraph is not required if the applicant establishes that their application for the particular structure is impractical. This structure must be shown by analysis, supported by test evidence, to be able to withstand the repeated loads of variable magnitude expected during its service life without detectable cracks. Appropriate safe-life scatter factors must be applied. **Until such time as all testing that is required for compliance with this subparagraph are completed, the replacement times provided in the ALS must be based upon the currently completed test life divided by the applicable scatter factor.**

(d) Sonic fatigue strength

It must be shown by analysis, supported by test evidence, or by the service history of aeroplanes of similar structural design and sonic excitation environment, that:

- (1) sonic fatigue cracks are not probable in any part of the flight structure subject to sonic excitation; or
- (2) catastrophic failure caused by sonic fatigue cracks is not probable assuming that the loads prescribed in subparagraph (b) of this **paragraph** are applied to all areas affected by those cracks.

(e) ~~Damage tolerance~~ (Discrete source) damage evaluation

The aeroplane must be capable of successfully completing a flight during which likely structural damage occurs as a result of ~~(1)~~ bird impact as specified in CS 25.631-

~~(2) Reserved~~

~~(3) Reserved~~

~~(4) Sudden decompression of compartments as specified in CS 25.365 (e) and (f).~~

The damaged structure must be able to withstand the static loads (considered as ultimate loads) which are reasonably expected to occur at the time of the occurrence and during the completion of the flight. Dynamic effects on these static loads need not be considered. Corrective action to be taken by the pilot following the incident, such as limiting manoeuvres, avoiding turbulence, and reducing speed, may be considered. If significant changes in structural stiffness or geometry, or both, follow from a structural failure or partial failure, the effect on damage tolerance must be further investigated. ~~(See AMC 25.571(a), (b) and (c), paragraph 2.7.2 and AMC 25.571 (b) and (e).)~~

(See AMC 25.571)

H25.1 General

- (a) This Appendix specifies requirements for the preparation of Instructions for Continued Airworthiness as required by CS 25.1529 and CS 25.1729.
- (b) ...
- (c) The applicant must consider the effect of ageing structures in the Instructions for Continued Airworthiness (see AMC 20-20).

H25.4 Airworthiness Limitations Section

- (a) The ICA must contain a section titled Airworthiness Limitations that is segregated and clearly distinguishable from the rest of the document. This section must set forth:
 - (1) Each mandatory **modification time**, replacement time, structural inspection interval, and related structural inspection procedure approved under CS 25.571.
 - ...
 - (4) An LoV of the engineering data that supports the structural maintenance programme, stated as a total number of accumulated flight cycles or flight hours or both, approved under CS 25.571. Until the full-scale fatigue testing is completed, the ALS must specify an interim limitation restricting aircraft operation to not more than half the number of the flight cycles or flight hours accumulated on the fatigue test article.
- (b) If the ICA consist of multiple documents, the section required by this paragraph must be included in the principal manual. This section must contain a legible statement in a prominent location that reads: 'The Airworthiness Limitations Section is approved and variations must also be approved'.

V. Replace AMC 25.571(a), (b) and (e), and AMC 25.571(b) and (e) by a new AMC 25.571 as follows:

AMC 25.571

Damage tolerance and fatigue evaluation of structure

1. PURPOSE

This AMC provides guidance for compliance with the provisions of CS 25.571 pertaining to the damage tolerance and fatigue evaluation requirements for aeroplane metallic and non-metallic structure. It also provides rational guidelines for the evaluation of scatter factors for the determination of life for parts categorised as safe-life. Additional Guidance Material for certification of non-metallic structures that must also comply with CS 25.571 is contained in AMC 20-29. Like all AMC, this AMC is not, in itself, mandatory and does not constitute a regulation. It is issued to provide an acceptable means, but not the only means, of compliance with the rules. Terms used in this AMC, such as 'shall' and 'must' are used only in the sense of ensuring applicability of this particular method of compliance when the acceptable method of compliance described herein is used. While these guidelines are not mandatory, they are derived from extensive authority and industry experience in determining compliance with the pertinent CS. This AMC does not change, create any additional, authorise changes in, or permit deviations from, regulatory requirements.

2. (RESERVED)

3. REFERENCES

CS 25.571,
CS 25.1529,
AMC 20-20 Continued Structural Integrity Programme,
AMC 20-29 Composite Structure.

4. DEFINITIONS OF TERMS USED IN THIS AMC

- (a) 'Damage tolerance' is the attribute of the structure that permits it to retain its required residual strength without detrimental structural deformation for a period of use after the structure has sustained a given level of fatigue, environmental, accidental, or discrete source damage.
- (b) Reserved.
- (c) 'Safe-life' of a structure is that number of events such as flights, landings, or flight hours, during which there is a low probability that the strength will degrade below its design ultimate value due to fatigue cracking.
- (d) 'Design Service Goal (DSG)' is the period of time in flight hours/cycles or calendar years, established at design and/or certification that represents the initially anticipated operational life of the aeroplane, during which the principal structure is expected to be reasonably free from significant cracking.
- (e) 'Principal Structure Element (PSE)' is an element that contributes significantly to the carrying of flight, ground, or pressurisation loads, and whose integrity is essential in maintaining the overall structural integrity of the aeroplane.

- (f) 'Detail Design Point (DDP)' is an area of structure that contributes to the susceptibility of the structure to fatigue cracking or degradation such that the structure cannot maintain its load carrying capability, which could lead to a catastrophic failure.
- (g) In 'single load path structure' the applied loads are carried through a single structural member, the failure of which would result in the loss of the structural capability to carry the applied loads.
- (h) Reserved.
- (i) In 'multiple load path structure' the applied loads are distributed through redundant structural members so that the failure of a single structural member does not result in the loss of structural capability to carry the applied loads.
- (j) 'Widespread Fatigue Damage (WFD)' in a structure is characterised by the simultaneous presence of cracks at multiple structural details that are of sufficient size and density whereby the structure will no longer meet the residual strength requirement of CS 25.571(b).
- (1) 'Multiple Site Damage (MSD)' is a source of widespread fatigue damage characterised by the simultaneous presence of fatigue cracks in the same structural element.
 - (2) 'Multiple Element Damage (MED)' is a source of widespread fatigue damage characterised by the simultaneous presence of fatigue cracks in adjacent structural elements.
 - (3) 'Structural modification point' is the point in time when a structural area must be modified to preclude WFD.
 - (4) 'Inspection start point' is the point in time when special inspections of the fleet are initiated due to a specific probability of having an MSD/MED condition.
- (k) 'Scatter factor' is a life reduction factor used in the interpretation of fatigue analysis and fatigue test results.
- (l) 'Limit of Validity (LoV)', or more explicitly the limit of validity of the engineering data that supports the structural maintenance programme, is not more than the period of time, stated as a number of total accumulated flight cycles or flight hours or both, for which it has been demonstrated that WFD is unlikely to occur in the aeroplane structure, and that the inspections and other maintenance actions and procedures resulting from this demonstration and the other elements of the fatigue and damage tolerance evaluation as provided for in the ALS and ICA are sufficient to prevent catastrophic failure of the aeroplane structure.
- (m) 'Normal maintenance' is understood to be those scheduled maintenance checks during minor or base maintenance inputs, normally associated with a zonal programme, requiring general visual inspections. The zonal programme is a collective term comprising selected general visual inspections and visual checks that are applied to each zone, defined by access and area, to check system and power plant installations and structure for security and general condition. A general visual inspection is a visual examination of an interior or exterior area, installation or assembly to detect obvious damage, failure or irregularity. This level of inspection is made from within touching distance unless otherwise specified. A mirror may be necessary to enhance visual access to all exposed surfaces in the inspection area. This level of inspection is made under normally available lighting conditions such as daylight, hangar

lighting, flashlight, or droplight and may require removal or opening of access panels or doors. Stands, ladders or platforms may be required to gain access.

- (n) 'Teardown inspection' is the process of disassembling structure and using destructive inspection techniques or visual (magnified glass and dye penetrant) or other and non-destructive inspection methods (eddy current, ultrasonic) to identify the extent of damage, within a structure, caused by fatigue, environmental and accidental damage.
- (o) 'Fail-safe' is the attribute of the structure that permits it to retain its required residual strength for a period of unrepaired use after the failure or partial failure of a principal structural element.
- (p) 'WFD_(average behaviour)' is the point in time when, without intervention, 50 % of the fleet is expected to develop WFD for a particular structure.
- (q) 'Level 1 corrosion' is:
 - (1) corrosion occurring between successive corrosion inspection tasks that is local and can be reworked or blended out within the allowable limit; or
 - (2) corrosion damage that is local and exceeds the allowable limit, but can be attributed to an event not typical of operator's usage of other aircraft in the same fleet (e.g. mercury spill); or
 - (3) corrosion where operator experience has demonstrated only light corrosion between each successive corrosion inspection task inspection; and, the latest corrosion inspection task results in rework or blend out that finally exceeds the allowable limit.

5. BACKGROUND

- (a) Since the early 1970s, there have been significant state-of-the-art and industry-practice developments in the area of structural fatigue and fail-safe strength evaluation of transport category aeroplanes. Recognising that these developments could warrant some revision of the existing fatigue requirements of § 25.571 and 25.573 of 14 CFR Part 25, the Federal Aviation Administration (FAA), on 18 November 1976 (41 FR 50956) gave notice of the Transport Category Aeroplane Fatigue Regulatory Review Programme and invited interested persons to submit proposals to amend those requirements. The proposals and related discussions formed the basis for the revision of the structural fatigue evaluation standards of § 25.571 and 25.573 and the development of guidance material. To that end, § 25.571 was revised, § 25.573 was deleted (the scope of § 25.571 was expanded to cover the substance of the deleted section), and guidance material (AC 25.571-1) was provided which contained compliance provisions related to the proposed changes.
- (b) Since the issuance of AC 25.571-1 on 28.9.1978, additional guidance material, including information regarding discrete source damage, was developed and incorporated in revision -1A on 5.3.1986. The AC was further revised on 18.2.1997 (revision 1B) to add guidance on the elements to be considered in developing safe-life scatter factors for certification. Although FAR, JAR and CS 25.571 have since 1978 required consideration of fatigue

damage originating at multiple sites, the FAA AC was further revised on 29.4.1998 (revision 1C) to add guidance material whose objective was to preclude widespread fatigue damage (resulting from MSD or MED) from occurring within the design service goal of the aeroplane, and to aid in the determination of thresholds for fatigue inspection and/or other special fleet actions. JAR/CS 25.571 were not harmonised with the 1998 amendment of FAR 25.571. Under the auspices of ARAC, the GSHWG drafted NPA 25C-292 proposing the LoV, greater emphasis on testing, corrosion and manufacturing and accidental damage in the 25.571 requirements and corresponding AC material to support this. EASA AMC 20-20 'Continuing Structural Integrity Programme' introduced the 'Limit of Validity (LoV)' concept in 2007. AC 25.571-1D issued on 13.1.2011 provides guidance in support of FAR 25 Amdt 134 which introduced the LoV requirement. Thus, the AMC 25.571 has been revised to provide guidance for establishing an LoV for the structural maintenance programme as will now be required by CS 25.571. In conclusion, this AMC revision based on the GSHWG work and recently developed FAA guidance, now better harmonises the EASA guidance with AC 25.571-1D and industry practice.

6. INTRODUCTION

(a) General

The content of this AMC is considered by EASA in determining compliance with the requirements of CS 25.571. The objective is to prevent catastrophic structural failures caused by fatigue damage (FD), environmental (e.g. corrosion) damage (ED), or accidental damage (AD).

The requirements can be grouped into two different categories. The first involves the establishment of mandatory maintenance actions to supplement the basic maintenance programme developed in compliance with CS 25.1529 and where appropriate in accordance with the MRBR, and the second one involves design. Taken together, they result in a structure where the combination of design characteristics and maintenance actions will serve to preclude any failure due to FD, ED, or AD.

CS 25.571(a)(3) requires the applicant to establish inspections or other procedures (herein also referred to as maintenance actions) as necessary to avoid catastrophic failure during the operational life of the aeroplane based on the results of the prescribed fatigue and damage tolerance evaluations.

CS 25.571(a)(5) requires development of inspections for ED and AD. CS 25.571(b) requires the applicant to establish an LoV. Furthermore, CS 25.571(b) and (c) require establishment of inspections and replacement times respectively based on the damage tolerance and fatigue characteristics of the structure. The LoV, in effect, is the operational life of the aeroplane consistent with evaluations accomplished and maintenance actions established to prevent WFD. The LoV is established based on WFD considerations and it is intended that all maintenance actions required to address fatigue, environmental (corrosion), and accidental damage up to the LoV are identified in the structural maintenance programme. All inspections and other procedures (e.g. modification times, replacement times) that are necessary to prevent a catastrophic failure due to fatigue, up to the LoV, must be included in the ALS of the ICA, as required by CS 25.1529, along with the LoV.

CS 25.571(d) requires the structure to be designed such that sonic fatigue cracking will not result in a failure. CS 25.571(e) requires the structure to be designed to withstand damage caused by specified threats such that the flight during which the damage is sustained can be completed.

(1) *CS 25.571(a)(5) – Environmental and accidental damage inspections and associated procedures*

Inspections for ED and AD must be defined. Special consideration should be given to those areas where past service experience indicates a particular susceptibility to attack by the environment or vulnerability to impact and/or abuse. It is intended that these inspections will be effective in discovering ED or AD soon after it appears or occurs, and that the ED or AD will, therefore, be removed/repared before it presents a significant risk. Typically these inspections are largely defined based on past service experience using a qualitative process in combination with the Maintenance Steering Group (MSG-3) process. For new structure and materials, testing may be required to evaluate likely AD and the subsequent tolerance of the design to it. In addition, for ED prevention, an effective CPCP is necessary, which will contain tasks and procedures in addition to inspections that will help prevent initiation and when necessary, the recurrence of corrosion (see AMC 20-20). Furthermore, CS 25.571 requires that the ALS must include a statement that requires the operator to include a CPCP in their maintenance programme that will ensure corrosion is controlled to Level 1 or better.

Any special inspections required for AD and ED, i.e. ones in addition to those that would be generated through the use of the MSG-3 process for AD and ED, or the CPCP development for ED, and which are necessary to prevent catastrophic failure of the aeroplane, must be included in the ALS of the ICA required by CS 25.1529. If a location is prone to accidental or environmental damage and the only means for detection is one that relies on the subsequent development of a fatigue crack from the original damage, then that inspection must be placed in the ALS of the ICA.

(2) *CS 25.571(b) and (c) – Fatigue damage inspections or replacement times*

Inspections for fatigue damage or replacement times must be established as necessary. These actions must be based on quantitative evaluations of the fatigue characteristics of the structure. In general, analysis and testing will be required to generate the information needed. The applicant should perform crack growth and residual strength testing to produce the design data needed to support crack growth and residual strength analyses. Full-scale fatigue test evidence is required to support the evaluation of structure that is susceptible to WFD. Test evidence is needed to support analysis used to establish safe-life replacement times.

(i) *Inspection or replacement*

Compliance with CS 25.571(b) is required unless it can be demonstrated to the satisfaction of the authority that compliance cannot be shown due to practical constraints. Under these circumstances, compliance with CS 25.571(c) is required. The only common example of structure where compliance with the requirements of CS 25.571(c), in lieu of CS 25.571(b), might be accepted, would be the landing gear and its local attachments.

(ii) ALS of the ICA

All inspections and replacement times necessary to detect or preclude fatigue cracking scenarios, before they become critical, must be included in the ALS of the ICA required by CS 25.1529.

(iii) Limit of Validity (LoV)

An LoV for the structural maintenance programme must also be determined and included in the ALS of the ICA. See section 11.0 of this AMC for additional guidance on the LoV.

(b) Typical loading spectrum expected in service

The loading spectrum should be based on measured statistical data of the type derived from government and industry load history studies and where insufficient data are available on a conservative estimate of the anticipated use of the aeroplane. The development of the loading spectrum includes the definition of the expected flight plan, which involves ground manoeuvres, climb, cruise, descent, flight times, operating speeds, weights and altitudes, and the approximate time to be spent in each of the operating regimes. The principal loads that should be considered in establishing a loading spectrum are flight loads (gust and manoeuvre), ground loads (taxiing, landing impact, turning, engine run-up, braking, thrust reversing and towing), and pressurisation loads. Operations for crew training and other pertinent factors, such as the dynamic stress characteristics of any flexible structure excited by turbulence or buffeting, should also be considered. For pressurised cabins, the loading spectrum should include the repeated application of the normal operating differential pressure and the superimposed effects of flight loads and aerodynamic pressures.

(c) Areas to be evaluated

When assessing the possibility of serious fatigue failures, the design should be examined to determine probable points of failure in service. In this examination consideration should be given, as necessary, to the results of stress analyses, static tests, fatigue tests, strain gauge surveys, tests of similar structural configurations, and service experience. Service experience has shown that special attention should be focused on the design details of important discontinuities, main attach fittings, tension joints, splices, and cut-outs such as windows, doors, and other openings. Locations prone to accidental damage (such as that due to the impact with ground servicing equipment near aeroplane doors) or to corrosion should be identified for analysis.

(d) Analyses and tests

Fatigue and damage tolerance analyses should be conducted unless it is determined that the normal operating stresses are of such a low order that crack initiation and, where applicable, significant damage growth is extremely improbable. Any method used in the analyses should be supported by test or service experience. Typical (average) values of fracture mechanics material properties may be used in residual strength and crack growth analyses. The effects of environment on these properties should be accounted for if significant.

Generally, testing will also be necessary to support compliance with CS 25.571(b) or (c). The nature and extent of testing of complete structures or portions will depend on applicable previous design and structural tests and service experience with similar structures. Structural areas such as attachment fittings, major joints, changes in section, cut-outs and

discontinuities almost always require almost always some level of testing in addition to analysis. When less than the complete structure is tested, care should be taken to ensure that the internal loads and boundary conditions are valid. Any tests conducted to support the identification of areas for evaluation should be conducted at least two times to the design service goal to obtain information on crack initiation times and locations.

(e) Discrete source damage

It must be shown that the aeroplane is capable of successfully completing a flight during which specified incidents occur and result in immediately obvious damage. The maximum extent of the damage must be quantified and the structure shown to be capable of sustaining the maximum load (considered as ultimate) expected during the completion of the flight. There are no maintenance actions that result from this evaluation.

7. DAMAGE TOLERANCE EVALUATION

(a) General

The damage tolerance requirements of CS 25.571(b) are intended to ensure that should fatigue, corrosion or accidental damage occur within the LoV, the structure will be capable of withstanding the loading conditions specified in CS 25.571(b)(1) through (b)(6) without failure or detrimental structural deformation until the damage is detected. The evaluation should include identifying the PSEs, defining the loading conditions and conducting sufficiently representative structural tests or analyses, or both, to provide sufficient data for the establishment of the inspection programme. Although this process applies to either single or multiple load path structure, the use of multiple load path structures should be given high priority in achieving a damage-tolerant design. The principle analytical tool used for metallic materials to perform a damage tolerance evaluation is based on Linear Elastic Fracture Mechanics. A discussion of this approach is presented in Appendix 1 of this Advisory Material. The means of establishing the LoV and maintenance actions specifically associated to WFD is addressed in detail in Section 11 of this AMC.

(b) Damage-tolerant characteristics

A damage-tolerant structure has two notable attributes:

- (1) The structure can tolerate a significant amount of damage, due to fatigue, environmental or accidental deterioration without compromising the continued airworthiness of the aeroplane (residual strength and rigidity).
- (2) The structure can sustain that damage long enough to be found and repaired during scheduled or unscheduled maintenance (inspectibility).

(c) Design considerations

To achieve a damage-tolerant structure, criteria should be established to guide the design process so that this design objective is achieved. The design process should include a damage tolerance evaluation (test and analysis) to demonstrate that the damage-tolerant design objectives are achieved, and to identify inspections or other procedures necessary to prevent catastrophic failure. Reliance on special inspections should be minimised by designing structure with easily detectable (e.g. visual) cracking modes. Since the occurrence of WFD can complicate a damage-tolerant evaluation to the point that reliable inspections programmes cannot be developed even with

extremely intensive inspection methods, it must be demonstrated, with sufficient full-scale fatigue test evidence, that adequate maintenance procedures are contained in the ALS of the ICA, such that WFD will not occur within the LoV. A discussion on several issues an applicant might face in demonstrating freedom from WFD is contained in Appendix 2 of this Advisory Material.

(d) Design features

Design features which should be considered in attaining a damage-tolerant structure include the following:

- (1) multiple load path construction and/or the use of damage containment features to arrest fast fracture or reduce the crack growth rate, and to provide adequate residual strength;
- (2) materials and stress levels that provide a slow rate of crack propagation combined with high residual strength; and
- (3) arrangement of design details to ensure a sufficiently high probability that a failure in any critical structural element will be detected before the strength has been reduced below the level necessary to withstand the loading conditions specified in CS 25.571(b).

(e) Probabilistic evaluations

No guidance is provided in this AMC on probabilistic evaluation. Normally, damage tolerance assessments consist of a deterministic evaluation of design features described in paragraphs 7d(1), (2) and (3). Paragraphs (f) to (k) below provide guidelines for this approach.

(f) PSEs, detail design points, and locations to be evaluated

In accordance with CS 25.571(a), a damage tolerance and fatigue evaluation should be conducted for each part of the structure which could contribute to a catastrophic failure. PSEs such as wing, empennage, control surfaces and their systems, the fuselage, engine mountings, landing gears, and their related primary attachments, and all DDPs susceptible to fatigue that could contribute to a catastrophic failure should be evaluated.

In accordance with CS 25.571(a)(1)(ii), this evaluation must include the identification of PSEs and DDPs, the failure of which could contribute to catastrophic failure of the aeroplane. As defined in this AMC, a principal structural element is an element of structure that contributes significantly to the carrying of flight, ground, or pressurisation loads and whose integrity is essential in maintaining the overall structural integrity of the aeroplane. When identifying PSEs, consideration should be given to the effect caused by partial or complete loss or failure of structure with respect to continued safe flight and landing, considering all flight phases including stability, control and aeroelasticity.

A DDP is an area at higher risk of fatigue cracking than other areas, and may warrant specific actions such as special inspections or other procedures to ensure continued airworthiness.

- (1) Locations requiring evaluation can be determined by analysis or by fatigue tests on complete structures or subcomponents. However, tests may be necessary when the basis for analytical prediction is not reliable, such as for complex components. If less than the complete structure is tested, care should be taken to ensure that the internal loads and boundary conditions are valid.

The selection criteria for DDPs should also include the following considerations:

- (a) any evidence of cracking encountered in service on comparable structure;
- (b) any evidence of cracking found during fatigue testing on comparable structure;
- (c) available strain gauge data;
- (d) locations where permanent deformation occurred on static test articles;
- (e) areas analytically shown to have relatively low crack initiation life;
- (f) susceptibility to corrosion or other environmental deterioration (e.g. disbanding);
- (g) potential for manufacturing anomalies (e.g. new or novel manufacturing processes where the potential for damage may not be well understood);
- (h) vulnerability to in-service induced accidental damage;
- (i) areas whose failure would create high stresses in the remaining structure;
- (j) elements in high tension or shear;
- (k) low static margin;
- (l) high stress concentrations;
- (m) high load transfer;
- (n) materials with high crack growth rates;
- (o) some DDPs may exist outside of PSEs and may also have been classified as fatigue-critical structure, e.g. undercarriage door attachments (see Appendix 5 for discussion on PSEs, FCS and DDP);
- (p) areas where detection of damage would be difficult;
- (q) location subject to vibrations or other mechanism that may lead to premature wear fastener holes; and
- (r) locations vulnerable to moisture ingress or retention.

(2) Examples of Principal Structural Elements (PSEs)

Typical examples of structure which are usually considered to be PSEs are:

- (i) Wing and empennage
 - (a) control surfaces, slats, flaps, and their mechanical systems and attachments (hinges, tracks, and fittings);
 - (b) primary fittings;
 - (c) principal splices;
 - (d) skin or reinforcement around cut-outs or discontinuities;
 - (e) skin-stringer combinations or integrally stiffened plates;

- (f) spar caps;
 - (g) spar webs; and
 - (h) ribs and bulkheads.
- (ii) Fuselage
- (a) circumferential frames and adjacent skin;
 - (b) pilot window posts;
 - (c) pressure bulkheads;
 - (d) skin and any single frame or stiffener element around a cut-out;
 - (e) skin or skin splices, or both, under circumferential loads;
 - (f) skin or skin splices, or both, under fore and aft loads;
 - (g) skin and stiffener combinations under fore and aft loads;
 - (h) door skins, frames, and latches;
 - (i) window frames; and
 - (j) floor beams⁴.
- (iii) Landing gear and their attachments
- (iv) Engine mounts and struts
- (v) Thrust reverser components, whose failure could result in inadvertent deployment
- (g) Inaccessible areas
- Every reasonable effort should be made to ensure inspectibility (reference CS 25.611) of all structural parts, and to qualify them under the damage tolerance provisions. In those cases where inaccessible and uninspectible blind areas exist, and suitable damage tolerance cannot practically be provided to allow for extension of damage into detectable areas or demonstrate sufficient residual strength up to the LoV without inspection, the structure should be shown to comply with the fatigue (safe-life) requirements in order to ensure its continued airworthiness. In this respect, particular attention should be given to the effects of corrosion and a CPCP is therefore also applicable to safe-life structures.
- (h) Residual strength testing of principal structural elements
- Analytical prediction of the residual strength of structures can be very complex due to non-linear behaviour, load redistribution and the potential for a multiplicity of failure modes. The nature and extent of residual strength tests will depend on previous experience with similar structures. Simulated cracks should be as representative as possible of actual fatigue damage. Where it is not practical to produce actual fatigue cracks, damage can be simulated by cuts made with a fine saw, sharp blade, guillotine, or other suitable means. Whatever artificial means are used to simulate sharp fatigue cracks, sufficient evidence should be available from element tests to indicate equivalent residual strength. If equivalency cannot be shown, every attempt should be made to apply enough cyclic loading to generate fatigue cracks from the artificial damage prior to applying residual strength loads. Special

⁴ Floor beams are not always critical but should be checked for criticality, particularly those located next to cut-outs or within non-circular pressurised sections.

consideration should be given to the procedure for pre-cracking so that subsequent test results are representative. This can be an issue when slow stable tearing in ductile sheet or plate material is part of the failure mechanism. Inappropriate pre-cracking loads can lead to unconservative results. In those cases where bolt failure, or its equivalent, is to be simulated as part of a possible damage configuration in joints or fittings, bolts can be removed to provide that part of the simulation.

(i) Damage tolerance analysis and tests

(1) It should be determined by analysis, supported by test evidence, that:

(i) the structure, with the extent of damage established for residual strength evaluation, can withstand the specified residual strength loads (considered as ultimate loads); and

(ii) the crack growth life under the repeated loads expected in service (between the time the damage becomes initially detectable and the time the extent of damage reaches the value for residual strength evaluation) provides a practical basis for development of the inspection programme and procedures described in paragraph 8 of this AMC.

(2) The repeated loads should be as defined in the loading, temperature, and humidity spectra. The loading conditions should take into account the effects of structural flexibility and rate of loading where they are significant.

(3) The damage tolerance characteristics can be shown analytically by reliable or conservative methods such as the following:

(i) By demonstrating quantitative relationships with structure already verified as damage-tolerant; or

(ii) By demonstrating that the repeated loads and residual strength load stresses do not exceed those of previously verified designs of similar configuration, materials, and inspectibility.

8. INSPECTION REQUIREMENTS

(a) Damage detection

Detection and repair of damage before it becomes critical is the most important factor in ensuring that the damage tolerance characteristics of the structure are maintained. For this reason, CS 25.571 requires that the applicant establish inspections or other procedures, as necessary, to prevent catastrophic failure from accidental, environmental, or fatigue damage, and include those inspections and procedures in the ALS of the Instructions for Continued Airworthiness required by CS 25.1529 (see also Appendix H to Part-25).

Due to the complex interactions of the many parameters that affect the damage tolerance evaluation, such as operating practices, environmental effects, load sequence effects on crack growth and variations in inspection methods, operational experience should be taken into account in establishing inspection thresholds, repeat intervals and inspection procedures.

(b) Environmental and accidental damage inspection programmes

The inspections developed under CS 25.571(b) are primarily for the detection of cracks developing from fatigue, accidental damage, and corrosion. As required by CS 25.571(a)(5), a separate programme needs to be

implemented for the early detection of environmental and accidental damage. This is intended to minimise the risk of:

- (1) interaction between corrosion and fatigue cracking;
- (2) accidental damage developing into fatigue cracks; or
- (3) corrosion developing due to accidental damage.

In many cases this can be accomplished through the MRB or equivalent process agreed by the Agency activity for a new large transport aeroplane model using ATA MSG-3 procedures. These procedures also require that a CPCP be developed.

For ED and AD programmes developed under the auspices of the MRB, the minimum ALS content associated with AD and ED may generally be limited to a reference to the documents that contain the MRBR derived maintenance tasks for AD and ED; and the need to incorporate and maintain an effective CPCP in the operators' programme; and a statement requiring operators to control corrosion to Level 1 or better. It is important to explain to operators the link between the AD and ED inspection programmes and CS 25.571 and CS 25.1529 compliance. Inspections that are designed to detect fatigue cracking resulting from AD or ED where the originating damage cannot otherwise be demonstrated to be detected prior to the development of the fatigue cracks must also be directly included in the ALS. For new structure where there is limited supporting data from service experience, the MRB will depend heavily on input from the analyses and test programmes conducted by the TCH during certification, and for this reason significant cooperation is required between those involved directly in certification and those participating in the MRBR development. Care should also be taken to ensure that the damage assumptions made remain conservative after entry into service. A check of the continued validity of the certification assumptions can be achieved through fleet leader programmes and robust reporting requirements. If there is any doubt about the likely performance of a completely new structure with respect to AD and ED, certain specific inspections in vulnerable areas may be better placed in the ALS.

Approval of CPCP may either be through the MRB (ISC) using existing procedures for EASA MRBR approval or directly by the Agency if no EASA approved MRBR exists for the Type. Subsequently, provided the operator has an NAA approved MP that controls corrosion to Level 1 or better, it need not to follow exactly the CPCP offered by the TCH. However, all revisions to the TCH's programme for ED and AD must be considered by the operator for incorporation in the operators MP under the Part-M requirements.

Changes and STCs must also be provided with inspection programmes that address ED and AD.

(c) Inspection threshold for fatigue cracking

The inspection threshold is the point in time at which the first planned structural inspection is performed following entry into service. The threshold may be as low as the repeat interval, or may allow for a longer period of operation, provided certain conditions are met.

The concept of delaying an inspection threshold beyond the repeat interval is based on the premise that it will take a certain amount of time before fatigue cracks would develop to a size that would be detectable during a structural inspection. Consequently, it may be acceptable to wait some period of time before starting to inspect for fatigue cracks.

CS 25.571(a)(4) requires inspection thresholds for certain structure to be derived from crack growth analysis or tests assuming that the structure contains an initial flaw of the maximum probable size that could exist as a result of manufacturing or service-induced damage. This approach applies to:

- (1) single load path structure, and
- (2) to multiple load path 'fail-safe' structure and crack arrest 'fail-safe' structure, where it cannot be demonstrated that the resulting load path failure or partial failure (including arrested cracks) will be detected and repaired during normal maintenance, inspection, or operation of an aeroplane prior to failure of the remaining structure.

In this context, normal maintenance includes general visual structural inspections for accidental and environmental damage derived from processes such as the MRB application of MSG-3. Inspections should begin early enough to ensure that there is a high confidence of detecting cracks before they could lead to a catastrophic structural failure, including cases where the structure is of a lower bound manufacturing quality or susceptible to accidental damage.

For the locations addressed by CS 25.571(a)(4) that are also susceptible to accidental damage, the assumed initial flaw size for crack growth determination of the threshold should not be less than that which can be supported by service experience or test evidence. For example, if the type of damage expected is well defined, e.g. it is limited to dents, then there may be data that supports a longer threshold than would be derived by the assumption of a similar sized crack. However, in this case, the worst case manufacturing flaw should still be considered as a crack. If this supporting data is not available (e.g. for a completely new design where no specific investigation of the accidental damage threats or their influence on fatigue has been made), then the fatigue cracking inspection threshold should be set equal to the repeat interval derived for a crack detectable by general visual inspection means, since the initial damage and its growth is not well defined and could occur at any time.

The remaining areas of the structure evaluated under CS 25.571(b), i.e. multiple load path 'fail-safe' structure and crack arrest 'fail-safe' structure, where it can be demonstrated that the resulting load path failure, partial failure, or crack arrest will be detected and repaired during normal maintenance, inspection, or operation of an aeroplane prior to failure of the remaining structure must also have thresholds established for fatigue cracking. For these locations, methods that do not account for worst-case damage may be used in lieu of crack growth analysis if desired. For example, fatigue SN analysis and tests with an appropriate scatter factor or slow crack growth analysis based on appropriate initial manufacturing damage, i.e. typical manufacturing flaws as opposed to the maximum probable flaw (e.g. a 0.127 mm corner crack representing a typical manufacturing flaw in a fastener hole versus a 1.27 mm crack representing the maximum probable flaw).

The means of establishing the LoV and maintenance actions (including inspections) specifically associated to WFD is addressed in detail in Section 11 of this AMC.

All inspections necessary to detect fatigue cracking must be included in the ALS unless the threshold is established to occur after the LoV.

Appendix 3 provides further details on threshold determination.

(d) Inspection

The basis for setting inspection intervals is the period of time during which damage is detectable and the residual strength remains above the required levels. The reliability of the repeat inspection programme (i.e. frequency of inspections and probability of detection) should assure damage detection before the residual strength of the aircraft is compromised. Inspection intervals must be established by applying appropriate reduction factors to this period to ensure that the crack or failed load path will typically be found well before the residual strength of the structure drops below the required level. Long periods of exposure to residual strength levels only just above the load limit should be avoided. This applies in particular to crack arrest structure. It should be borne in mind that CS 25.305 is the principle requirement for strength of the airframe, and that CS 25.571 is primarily intended to provide an inspection programme that will ensure the timely detection and repair of damage in order to restore the aircraft to the required (CS 25.305) strength capability and preserve this capability throughout the majority of the aircraft's operational life.

Detectable crack sizes and shapes assumed to determine inspection intervals should be consistent with the inspection method capabilities and the cracking characteristics of the structure being evaluated. If concurrent cracking in adjacent areas or surrounding structure is expected within the operational life of the aeroplane, then this should be accounted for in the cracking scenario assumed.

9. FATIGUE (SAFE-LIFE) EVALUATION

9.1. Reserved

9.2. Fatigue (safe-life) evaluation

9.2.1. General

The evaluation of structure under the following fatigue (safe-life) strength evaluation methods is intended to ensure that catastrophic fatigue failure, as a result of the repeated loads of variable magnitude expected in service, will be avoided throughout the structure's operational life. Under these methods the fatigue life of the structure should be determined. The evaluation should include the following:

- (a) estimating or measuring the expected loading spectra of the structure;
- (b) conducting a structural analysis including consideration of the stress concentration effects;
- (c) performing fatigue testing of structure which cannot be related to a test background to establish response to the typical loading spectrum expected in service;
- (d) determining reliable replacement times by interpreting the loading history, variable load analyses, fatigue test data, service experience, and fatigue analysis;
- (e) Evaluating the possibility of fatigue initiation from sources such as corrosion, stress corrosion, disbanding, accidental damage and manufacturing defects based on a review of the design, quality control and past service experience; and

- (f) Providing necessary maintenance programmes and replacement times to the operators. The maintenance programme should be included in the ICA in accordance with CS 25.1529.

9.2.2. Scatter factor for safe-life determination

In the interpretation of fatigue analyses and test data the effect of variability should, under CS 25.571(c), be accounted for by an appropriate scatter factor. In this process it is appropriate that the applicant justify the scatter factor chosen for any safe-life part. The following guidance is provided (see Figure 1):

- (a) the base scatter factors applicable to test results are: $BSF1 = 3.0$, and $BSF2 =$ (see paragraph 9.2.2(e) of this AMC). If the applicant can meet the requirements of 9.2.2(c) of this AMC, he/she may use $BSF1$ or, at his/her option, $BSF2$;
- (b) the base scatter factor, $BSF1$, is associated with test results of one representative test specimen;
- (c) justification for use of $BSF1$. $BSF1$ may only be used if the following criteria are met:
- (i) Understanding of load paths and failure modes

Service and test experience of similar in-service components that were designed using similar design criteria and methods should demonstrate that the load paths and potential failure modes of the components are well understood.
 - (ii) Control of design, material and manufacturing process quality

The applicant should demonstrate that his/her quality system (e.g. design, process control, and material standards) ensures the scatter in fatigue properties is controlled, and that the design of the fatigue-critical areas of the part account for the material scatter.
 - (iii) Representativeness of the test specimen
 - (A) The test article should be full scale (component or subcomponent) and represent that portion of the production aircraft requiring test. All differences between the test article and the production article should be accounted for either by analysis supported by test evidence or by testing itself.
 - (B) Construction details, such as bracket attachments, clips, etc., should be accounted for, even though the items themselves may be non-loadbearing.
 - (C) Points of load application and reaction should accurately reflect those of the aircraft, ensure correct behaviour of the test article, and guard against uncharacteristic failures.
 - (D) Systems used to protect the structure against environmental degradation can have a negative effect on fatigue life and therefore should be included as part of the test article.
- (d) Adjustments to base scatter factor $BSF1$. Having satisfied the criteria of paragraph 9.2.2(c), justifying the use of $BSF1$, the base value of 3.0 should be adjusted to account for the following considerations, as necessary, where not wholly taken into account by design analysis. As a result of the adjustments, the final scatter factor may be less than, equal to, or greater than 3.0.

- (i) *Material fatigue scatter.* Material properties should be investigated up to a 99 % probability of survival and a 95 % level of confidence.
 - (ii) *Spectrum severity.* Test load spectrum should be derived based on a spectrum sensitive analysis accounting for variations in both utilisation (i.e. aircraft weight, cg, etc.) and occurrences/size of loads. The test loads spectrum applied to the structure should be demonstrated to be conservative when compared to the expected in-service.
 - (iii) *Number of representative test specimens.* Well established statistical methods should be used that associate the number of items tested with the distribution chosen to obtain an adjustment to the base scatter factor.
- (e) If the applicant cannot satisfy the intent of all of paragraph 9.2.2(c) of this AMC, BSF2 should be used.
- (i) The applicant should propose scatter factor BSF2 based on careful consideration of the following issues: the required level of safety, the number of representative test specimens, how representative the test is, expected fatigue scatter, type of repeated load test, the accuracy of the test loads spectrum, spectrum severity, and the expected service environmental conditions.
 - (ii) In no case should the value of BSF2 be less than 3.0.
- (f) Resolution of test loadings to actual loadings. The applicant may use a number of different approaches to reduce both the number of load cycles and the number of test set-ups required. Due to the modifications to the flight-by-flight loading sequence, the applicant should propose either analytical or empirical approaches to quantify an adjustment to the number of test cycles which represents the difference between the test spectrum and the assumed flight-by-flight spectrum. In addition, an adjustment to the number of test cycles may be justified by raising or lowering the test load levels as long as appropriate data support the applicant's position. Other effects to be considered are different failure locations, different response to fretting conditions, temperature effects, etc. The analytical approach should use well-established methods or be supported by test evidence.

CS-25 BOOK 2

SCATTER FACTOR FLOW CHART

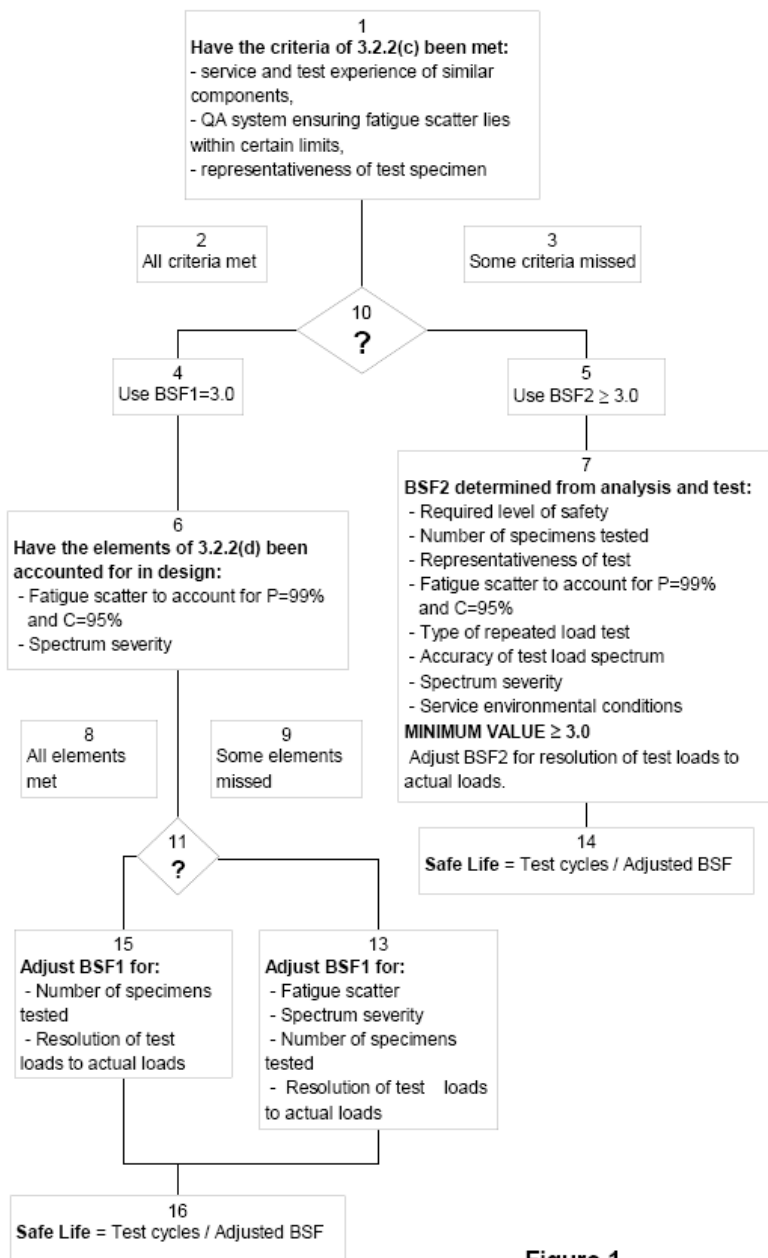

Figure 1

9.3. Replacement times

Replacement times should be established for parts with established safe-lives and should, under CS 25.571(a)(3), be included in the information prepared under CS 25.1529. These replacement times can be extended if additional data indicates an extension is warranted. Important factors which should be considered for such extensions include, but are not limited to, the following:

9.3.1. Comparison of original evaluation with service experience

9.3.2. Recorded load and stress data

Recorded load and stress data entails instrumenting aeroplanes in service to obtain a representative sampling of actual loads and stresses experienced. The data to be measured includes airspeed, altitude and load factor versus time data; or airspeed, altitude and strain ranges versus time data; or similar data. This data, obtained by instrumenting aeroplanes in service, provides a basis for correlating the estimated loading spectrum with the actual service experience.

9.3.3. Additional analyses and tests

If additional test data and analyses based on repeated load tests of additional or surviving specimens are obtained, a re-evaluation of the established safe-life can be made.

9.3.4. Tests of parts removed from service

Repeated load tests of replaced parts can be utilised to re-evaluate the established safe-life. The tests should closely simulate service loading conditions.

Repeated load testing of parts removed from service is especially useful where recorded load data obtained in service are available since the actual loading experienced by the part prior to replacement is known.

9.3.5. Repair or rework of the structure

In some cases, repair or rework of the structure can gain further life.

9.4. Type design developments and changes

For design developments, or design changes, involving structural configurations similar to those of a design already shown to comply with the applicable provisions of CS 25.571(c), it might be possible to evaluate the variations in critical portions of the structure on a comparative basis. Typical examples would be redesign of the wing structure for increased loads, and the introduction in pressurised cabins of cut-outs having different locations or different shapes, or both. This evaluation should involve analysis of the predicted stresses of the redesigned primary structure and correlation of the analysis with the analytical and test results used in showing compliance of the original design with CS 25.571(c).

10. DISCRETE SOURCE DAMAGE

(a) General

The purpose of this section is to establish the EASA guidelines for the consistent selection of load conditions for residual strength substantiation in showing compliance with CS 25.571(e) and CS 25.903(d). The intent of these guidelines is to define, with a satisfactory level of confidence, the load conditions that will not be exceeded on the flight during which the specified incident of CS 25.571(e) or CS 25.903(d) occurs. In defining these load

conditions, consideration has been given to the expected damage to the aeroplane, the anticipated response of the pilot at the time of the incident, and the actions of the pilot to avoid severe load environments for the remainder of the flight consistent with his/her knowledge that the aeroplane may be in a damaged state. Under CS 25.631 continued safe flight and landing is required following the bird impact. Following the guidance of this paragraph for assessing structural damage to any part whose failure or partial failure may prevent continued safe flight and landing is an Acceptable Means of Compliance to CS 25.631.

- (b) The maximum extent of immediately obvious damage from discrete sources (CS 25.571 (e)) should be determined and the remaining structure shown, with an acceptable level of confidence, to have static strength for the maximum load (considered as ultimate load) expected during completion of the flight. For uncontained rotor failure addressed under the CS 25.903(d) requirements and for applicants following AMC 20-128A, likely structural damage may be assumed to be equivalent to that obtained by using the rotor burst model and associated trajectories defined in AMC 20-128A, paragraph 9.0 'Engine and APU Failure Model'. This assessment should also include an evaluation of the controllability of the aircraft in the event of damage to the flight control system.
- (c) The loads considered as ultimate should not be less than those developed from the following:
- (1) At the time of the occurrence:
 - (i) the maximum normal operating differential pressure, multiplied by a 1.1 factor, combined with 1.0 g flight loads including the external aerodynamic pressures;
 - (ii) starting from 1.0 g level flight at speeds up to V_c , any manoeuvre or any other flight path deviation caused by the specified incident of CS 25.571(e), taking into account any likely damage to the flight controls and pilot normal corrective action.
 - (2) For the continuation of the flight, the maximum appropriate cabin differential pressure (including the external aerodynamic pressure), combined with:
 - (i) seventy per cent (70 %) of the limit flight manoeuvre loads as specified in 25.571(b) and, separately;
 - (ii) at the maximum operational speed, taking into account any appropriate reconfiguration and flight limitations, the 1.0 g loads plus incremental loads arising from application of forty per cent (40 %) of the limit gust velocity and turbulence intensities as specified in 25.341 at V_c .
- (d) At any time, the aeroplane must be shown by analysis to be free from flutter up to the boundary of the aeroelastic stability envelope described in CS 25.629(b)(2) with any change in structural stiffness resulting from the incident, consistent with CS 25.629(d)(8), CS 25.571(e) and CS 25.903(d).

11. ESTABLISHING THE LoV AND MAINTENANCE ACTIONS TO PREVENT WFD**(a) Structural maintenance programme**

Theoretically, if an aircraft is properly maintained it could be operated indefinitely. However, it should be noted that structural maintenance tasks for an aircraft are not constant with time. Typically, tasks are added to the maintenance programme as the aircraft ages. It is reasonable to expect then that confidence in the effectiveness of the current structural maintenance tasks may not, at some future point, be sufficient for continued operation.

Maintenance tasks for a particular aircraft can only be determined based on what is known about that aircraft model at any given time: from analyses, tests, service experience, and teardown inspections. Widespread fatigue damage is of particular concern because inspection methods cannot be relied on solely to ensure the continued airworthiness of aircraft indefinitely. When inspections are focused on details in small areas and have a high probability of detection, they may be used by themselves to ensure continued airworthiness, unless or until there are in-service findings. Based on findings, these inspections may need to be modified, and it may be necessary to modify or replace the structure rather than continue with the inspection alone. When inspections examine multiple details over large areas for relatively small cracks, they should not be used by themselves. Instead, they should be used to supplement the modification or replacement of the structure. This is because it would be difficult to achieve the probability of detection required to allow inspection to be used indefinitely as a means to ensure continued operational safety.

To prevent WFD from occurring, the structure must therefore occasionally be modified or replaced. Establishing all the replacements and modifications required to operate the aircraft indefinitely is an unbounded problem. This problem is solved by establishing a limit of validity of the engineering data that supports the structural maintenance programme. All necessary modifications and replacements are required to be established to ensure continued airworthiness up to the LoV. See paragraph 11(c) for the steps to extend the LoV.

(b) Widespread Fatigue Damage

Structural fatigue damage is progressive. It begins as minute cracks, and those cracks grow under the action of repeated stresses. It can be due to normal operational conditions and design attributes, or to isolated incidents, such as material defects, poor fabrication quality, or corrosion pits, dings, or scratches. Fatigue damage can occur locally, in small areas or structural design details, or globally. Global fatigue damage is general degradation of large areas of structure with similar structural details and stress levels. Global damage may occur within a single structural element, such as a single rivet line of a lap splice joining two large skin panels (multiple site damage). Or it may be found in multiple elements, such as adjacent frames or stringers (multiple element damage). Multiple site damage and multiple element damage cracks are typically too small initially to be reliably detected with normal inspection methods. Without intervention these cracks will grow, and eventually compromise the structural integrity of the aircraft in a condition known as widespread fatigue damage. Widespread fatigue damage is increasingly likely as the aircraft ages, and is certain if the aircraft is operated long enough without any intervention.

(c) Steps for establishing an LoV

The LoV is established as an upper limit to aeroplane operation with the inspections and other procedures provided under CS 25.1529 and Appendix H. The LoV is required by CS 25.571(a)(3) and is established because of increased uncertainties in fatigue and damage tolerance assessment and the probable development of widespread fatigue damage associated with aeroplane operation past the limit. In the future, in order to revise the LoV established at certification, the structural maintenance programme will need to be revalidated through a structural integrity and widespread fatigue damage audit to establish additional maintenance actions to prevent the occurrence of WFD in the fleet up to the revised LoV. Repairs and modifications made to individual aircraft will also need to be assessed to ensure that appropriate inspections and other procedures necessary to ensure safe operation up to the revised LoV are in place (AMC 20-20 provides further guidance on continued structural integrity programmes for ageing aircraft). To support the establishment of the LoV the applicant must demonstrate by test evidence and analysis at a minimum and, if available, service experience and teardown inspection results of high-time aircraft, that WFD is unlikely to occur in that aircraft up to the LoV.

The process for establishing an LoV involves four steps:

- identifying a 'candidate LoV';
- identifying WFD-susceptible structure;
- performing a WFD evaluation of all susceptible structure;
- finalising the LoV and establishing necessary maintenance actions.

Step 1 – Candidate LoV

Any LoV can be valid as long as it has been demonstrated that the aircraft model will be free from WFD up to the LoV based on the aircraft's inherent fatigue characteristics and that any required maintenance actions are in place. Early in the certification process applicants typically establish design service goals or their equivalent and set a design service objective to have structure remain relatively free from cracking, up to the design service goal. A recommended approach sets the 'candidate LoV' equal to the design service goal. The final LoV would depend on both how well that design objective was met and the applicant's consideration of the economic impact of maintenance actions required to preclude WFD up to the final LoV.

Step 2 – Identify WFD-susceptible structure

The applicant should identify the structure that is susceptible to WFD to support post-fatigue test teardown inspections or residual strength testing necessary to demonstrate that WFD will not occur in the aircraft structure up to the LoV. Appendix 2 of AMC 20-20 provides examples and illustrations of structure where multiple site damage or multiple element damage has been documented. The list in Appendix 2 to AMC 20-20 is not meant to be inclusive of all structure that might be susceptible to WFD on any given aircraft model and it should only be used for general guidance. It should not be used to exclude any particular structure.

The applicant should do the following when developing the list of structure susceptible to WFD:

- (1) Establish criteria that could be used for identifying what structure is susceptible to WFD based on the definitions of multiple site damage, multiple element damage, and WFD. For example, structural details and elements that are repeated over large areas and operate at the same stress levels are obvious candidates. The criteria should be part of the applicant's compliance data.
- (2) Provide supporting rationale for including and excluding specific structural areas. This should be part of the applicant's compliance data.
- (3) Identify the structure to a level of detail required to support post-test activities that the applicant will use to evaluate the residual strength capabilities of the structure. Structure is free from WFD if the residual strength meets or exceeds that required by CS 25.571(b). Therefore, post-test activities such as teardown inspections and residual strength tests must provide data that support the determination of strength.
 - For teardown inspections, specific structural details (e.g. holes, radii, fillets, cut-outs) need to be identified.
 - For residual strength testing, the identification at the component or subcomponent level (e.g. longitudinal skin splices) may be sufficient.

Step 3 – Evaluation of WFD-susceptible structure

Applicants must evaluate all susceptible structure identified in Step 2. Applicants must demonstrate by full-scale fatigue test evidence that WFD will not occur in the aircraft structure prior to the LoV. This demonstration typically entails full-scale fatigue testing, followed by teardown inspections and a quantitative evaluation of any finding or residual strength testing, or both. Additional guidance about full-scale fatigue test evidence is included in Appendix 2 to this AMC.

Step 4 – Finalise LoV

After all susceptible structure has been evaluated, finalise the LoV. The results of the evaluations performed in Step 3 will either demonstrate that the strength at the candidate LoV meets or exceeds the levels required by CS 25.571(b) or not. If it is demonstrated that the strength is equal to or greater than that required, the final LoV could be set to the candidate LoV without further evidence. If it is demonstrated that the strength is less than the required level, at least two outcomes are possible:

- (1) the final LoV may be equal with the candidate LoV. However, this would result in maintenance actions, design changes prior to entry into service, or both, maintenance actions and design changes, to support operation of aircraft up to LoV. For MSD/MED, the applicant may use damage tolerance-based inspections to supplement the replacement or modification required to preclude WFD when those inspections have been shown to be practical and reliable.
- (2) the final LoV may be less than the candidate LoV. This could reduce the need for maintenance actions or making design changes.

Maintenance actions

In some cases maintenance actions may be necessary for an aircraft to reach its LoV. These maintenance actions could include inspections, modifications,

replacements, or any combination thereof. The applicant must substantiate the maintenance actions according to the guidance contained in this AMC and in AMC 20-20.

- For initial certification, these actions should be specified as airworthiness limitation items and incorporated into the ALS of the ICA.
- For post-certified aircraft, these actions should be specified as service information by the TC holder or included in an updated ALS and may be mandated by Airworthiness Directives.

Design changes

The applicant may determine that developing design changes to prevent WFD in future production aircraft is to their advantage. The applicant must substantiate the design changes according to the guidance contained in this AMC (see Appendix 2).

In addition to the technical considerations, the LoV may be influenced by several other factors, including:

- maintenance considerations;
- operator's input;
- economics.

(d) Airworthiness Limitations Section (ALS)

In accordance with Part 21 the type certificate holder must provide the ICA (which include the ALS) with the aircraft. However, the type certificate holder may or may not have completed the full-scale fatigue test programme at the time of type certification.

(1) Fatigue testing is not completed.

Under CS 25.571, EASA may issue a type certificate for an aircraft model prior to the applicant's completion of the full-scale fatigue testing, provided that EASA has agreed to the applicant's plan for completing the required tests.

Until the full-scale fatigue testing is completed and EASA has approved the LoV, the type certificate holder must establish a limitation that is equal to not more than one half of the number of cycles accumulated on the test article supporting the WFD evaluation. Under Appendix H to CS-25, the ALS must contain the limitation preventing operation of the aircraft beyond one half of the number of cycles accumulated on the fatigue test article approved under CS 25.571. This limitation is an airworthiness limitation. No aircraft may be operated beyond this limitation until fatigue testing is completed and an LoV is approved. As additional cycles on the fatigue test article are accumulated this limitation may be adjusted accordingly. Upon completion of the full-scale fatigue test, applicants should perform specific inspections and analyses to determine whether WFD has occurred. Additional guidance on post-test WFD evaluations is included in Appendix 2 to this AMC.

At the time of type certification, the applicant should also show that at least one calendar year of safe operation has been substantiated by the fatigue test evidence agreed to be necessary to support other elements of the damage tolerance and safe-life substantiations. Some of these

tests may require application of scatter factors greater than two resulting in more restrictive operating limitations on some parts of the structure.

(2) Fatigue testing is completed.

After the full-scale fatigue test and the WFD evaluation have been completed, the applicant must include the following in the ALS:

- under Appendix H to CS 25, the ALS must contain the LoV stated as a number of total accumulated flight cycles or flight hours approved under CS 25.571;
- depending on the results of the evaluation under Step 3 above, the ALS may also include requirements to inspect, modify or replace the structure.

(e) Repairs and type design changes

Any person applying for a change to a type certificate (TC) or a supplemental type certificate (STC) must demonstrate that any affected structure is free from WFD up to the LoV. (*Note:* It is possible that the STC applicant may generate a new LoV for the aeroplanes as part of the STC limitations).

Applicants for a major repair to the original aircraft or to an aircraft modified under a major change or an STC must demonstrate that any affected structure is free from WFD up to the LoV.

The evaluation should assess the susceptibility of the structure to WFD and, if it is susceptible, demonstrate that WFD will not occur prior to the LoV. If WFD is likely to occur before LoV is reached, the applicant must either:

- (1) redesign the proposed repair to preclude WFD from occurring before the aircraft reaches the LoV; or
- (2) develop maintenance actions to preclude WFD from occurring before the aircraft reaches the LoV; or
- (3) for significant major changes and STCs only, establish a new LoV.

For repairs, the applicant must identify and include these actions as part of the repair. For major changes and STCs, the applicant must identify and include these actions as airworthiness limitation items in the ALS of the ICA.

Appendix 1 – Crack growth analysis and tests

Crack growth characteristics should be determined for each detail design point identified in accordance with 7(f) above. This information, when combined with the results from the residual strength analyses and tests, will be the basis for establishing the inspection requirements as discussed in Section 8. Crack growth characteristics can be determined by analysis or test. However, due to the large number of detail design points that are typically evaluated and the practical limitations involved with testing, analyses are generally relied on to determine crack growth at the detail design point.

- (a) *Analyses.* In order to perform a crack growth analysis a number of key elements are needed. These include 1) a load/stress spectrum applicable to the detail design point, 2) an initial crack size and shape to be assumed, 3) a cracking scenario to be followed, 4) applicable stress intensity solution(s), 5) a crack growth algorithm, and 6) material crack growth rate properties.

A loading spectrum must be developed for each detail design point. It is derived from the overall aircraft usage spectrum that is discussed in Section 6, para (b). The spectra at each detail design point may be modified for various reasons. The most common modification for metallic structure involves the deletion of high infrequent loads that may have an unrepresentative beneficial effect on crack growth if retardation is considered. Also, local load events that are not part of the overall aircraft spectrum should be included (e.g. flutter damper loads during pre-flight control surface checks).

The initial crack size and shape and subsequent cracking scenario to be followed are problem-dependent. Guidance on this is given in Appendix 4.

Applicable stress intensity solutions may be available in the public domain or may need to be developed. Many references exist which provide technical guidance for the application and development of stress intensity solutions. Care should be taken to ensure that the reference stress used for the spectrum load and stress intensity solution are compatible.

Crack growth algorithms used in predicting crack extension range from simple linear models to complex ones that can account for crack growth retardation and acceleration. It is generally accepted that the use of a linear model will result in conservative results. A non-linear model on the other hand can be conservative or unconservative and generally requires a higher level of validation and analysis/test correlation to adequately validate the accuracy of the algorithm. Coupon testing should be performed using representative materials and spectra types (e.g. wing lower cover, pylon support lug, horizontal stabiliser upper cover) that will be encountered in the course of the overall aircraft crack growth evaluation.

Crack growth rate data (e.g. da/dN vs ΔK vs R , da/dN vs ΔK_{eff}) for many common aerospace materials is available in the public domain. Additionally, testing standards (e.g. ASTM) exist for performing tests to gather this data. The generally accepted practice is to use typical or average representation of this data for performing crack growth evaluations.

- (b) *Tests.* Crack growth testing using coupons is typically performed to generate crack growth rate data and to validate crack growth algorithms used for

analyses. Simple specimens are generally used that have well-established stress intensity solutions for the characteristic cracking that can be expected. The primary issue for these tests is the pre-cracking required to achieve a well-behaved fatigue crack before data is collected. Effective pre-cracking procedures (e.g. 'load shedding') have been established and are described in the public domain. Care must be taken to ensure that subsequent crack growth is not affected by the prior pre-cracking.

In order to minimise the test time for actual structural components and/or full-scale test articles, the test loading spectrum may be modified by eliminating small magnitude load events or by replacing them with a fewer number of larger load events that give equivalent crack growth.

Crack growth behaviour may be obtained from actual structural components and/or full-scale test articles. However, inducing active fatigue cracks of the desired initial size and at the desired locations can be extremely difficult. Past success in obtaining useful data has been achieved on an opportunistic basis when natural fatigue cracks have developed in the course of normal cyclic testing. Naturally occurring and artificially induced fatigue cracks may be monitored and data collected for at least a portion of the overall crack growth period to be used for setting inspection requirements. This data can be extremely useful in supplementing and validating the analytical predictions, in some cases it may be the sole basis for the establishment of inspection requirements. Where fatigue test crack growth data is used, the results should be corrected to address expected operational environmental conditions.

Appendix 2 – Full-scale fatigue test evidence

(a) Overview

CS 25.571(b) requires that special consideration for widespread fatigue damage (WFD) be included where the design is such that this type of damage could occur. This Appendix focuses on the test evidence in support of establishing the LoV and applicants will also need to consider and agree with the Agency the extent of testing required in support of compliance with CS 25.571 in general, in particular for validation of hot spots, areas of complex loading exhibiting crack growth, single load path components and safe-life items. CS 25.571(b) requires the effectiveness of the provisions to preclude the possibility of widespread fatigue damage occurring within the limits of validity of the structural maintenance programme to be demonstrated with sufficient full-scale fatigue test evidence. The determination of what constitutes 'sufficient full-scale test evidence' requires a considerable amount of engineering judgment and is a matter that should be discussed and agreed to between the applicant and EASA early in the planning stage for a certification project. In general, sufficient full-scale test evidence to support an LoV consists of full-scale fatigue testing to at least two times the LoV, followed by specific inspections and analyses to determine that widespread fatigue damage has not occurred. It may be appropriate to allow for three life times of testing, especially if inspection may not be practical for areas subject to WFD and requiring SMPs to be established. The following factors should be considered in determining the sufficiency of evidence:

Factor 1: The comparability of the load spectrum between the test and the projected usage of the aeroplane.

Factor 2: The comparability of the airframe materials, design and build standards between the test article and the certified aeroplane.

Factor 3: The extent of post-test teardown inspection and analysis for determining if widespread fatigue cracking has occurred.

Factor 4: The duration of the fatigue testing.

Factor 5: The size and complexity of a design or build standard change. This factor applies to design changes made to a model that has already been certified and for which full-scale fatigue test evidence for the original structure should have already been determined to be sufficient. Small, simple design changes, comparable to the original structure, could be analytically determined to be equivalent to the original structure in their propensity for WFD. In such cases, additional full-scale fatigue test evidence should not be necessary.

Factor 6: In the case of major changes and STCs, the age of an aeroplane being modified. This factor applies to aeroplanes that have already accumulated a portion of their design service goal prior to being modified. An applicant should only be required to demonstrate freedom from WFD up to the LoV in place for the original aeroplane.

(b) *Elements of a full-scale fatigue test programme*

The following guidance addresses elements of a test programme that is intended to generate the data necessary to support compliance. It is generally applicable to all certification projects.

(1) *Article.* The test article should be representative of the structure of the aircraft to be certified (i.e. ideally a production standard article). The attributes of the type design that could affect MSD/MED initiation, growth and subsequent residual strength capability should be replicated as closely as possible on the test article. Critical attributes include, but are not limited to, the following:

- material types and forms,
- dimensions,
- joining methods and details,
- coating and plating,
- use of faying surface sealant,
- assembly processes and sequences, and
- influence of secondary structure (e.g. loads induced due to proximity to the structure under evaluation).

(2) *Test set-up and loading.* The test set-up and loading should result in a realistic simulation of expected operational loads.

(i) *Test set-up.* The test set-up dictates how loads are introduced into the structure and reacted. Every effort should be made to introduce and react loads as realistically as possible. When compromise is made (e.g. wing air loading) the resulting internal loads should be evaluated (e.g. using finite element methods) to ensure that the structure is not being unrealistically underloaded or overloaded locally or globally.

(ii) *Test loading.* The test loading spectrum should include loads from all damaging sources (e.g. cabin pressurisation, manoeuvres, gusts, engine thrust, control surface deflection, and landing impact) that are significant for the structure being evaluated. Supporting rationale should be provided when a source is not represented in a sequence. Additionally, differences between the test sequence and expected operational sequence should be justified. For example it is standard practice to eliminate low loads that are considered to be non-damaging and clip high infrequent loads that may unconservatively bias the outcome but care should be taken in both cases so that the test results are representative. Section 9.2.2(f) provides some guidance on justifying the test loading sequence.

(3) *Test duration.* AMC 20-20 includes guidance on how to establish mandatory maintenance actions for WFD-susceptible structure needed to preclude WFD occurrence in that structure. For any WFD-susceptible area the average time in flight cycles and/or hours to develop WFD must first be determined. This is referred to as the WFD_{average behaviour} for the subject area. The AMC 20-20 guidance states that the area should be modified/replaced at one third of this time unless inspection for

MSD/MED is practical. If inspection is practical the guidance states that inspection should start at one third of the WFD *average behaviour* with modification/replacement at one half of that time. It is standard practice to interpret the unfactored fatigue life of one specimen as the average life. It follows that if a full-scale fatigue test article survives a test duration of X without WFD occurrence it can be conservatively assumed that the WFD *average behaviour* of all susceptible areas is equal to X. Based on this, and assuming that the susceptible areas are impractical to inspect for MSD/MED, the guidance of AMC 20-20 would require that replacement/modification would have to be implemented at X/3. For areas where MSD/MED inspections were practical replacement/modification could be deferred until X/2, but MSD/MED inspections would have to start at X/3. The preceding should be kept in mind when deciding what the test duration will be.

(4) *Post-test evaluation.* One of the primary objectives of the full-scale fatigue test is to generate data needed to determine the absolute WFD *average behaviour* for each susceptible area or to establish a lower bound. Recall that the definition of WFD *average behaviour* is the average time required for MSD/MED to initiate and grow to the point that the static strength capability of the structure is reduced below the residual strength requirements of CS 25.571(b). Some work is required at the end of the test to determine the strength capability of the structure either directly or indirectly.

(i) *Residual strength tests.* The direct way to demonstrate freedom from WFD at the end of a full-scale fatigue test is to subject the article to the required residual strength loads specified in CS 25.571(b). If the test article sustains the loads it can be concluded that the point of WFD has yet to be reached for any areas. However, because fatigue cracks that might exist at the end of the test are not quantified it is not possible to determine how far beyond the test duration WFD would occur in any of the susceptible areas without accomplishing additional work (e.g. teardown inspection). Additionally, metallic test articles may be unconservatively compromised relative to their future fatigue performance if static loads in excess of representative operational loads are applied. Residual strength testing could preclude the possibility of using an article for additional fatigue testing.

(ii) *Teardown inspections.* The residual strength capability may be evaluated indirectly by performing teardown inspections to quantify the size of any MSD/MED cracks that might be present or to establish a lower bound on crack size based on inspection method capability. Once this is done the residual strength capability can be estimated analytically. Depending on the results crack growth analyses may also be required to project backwards or forwards in time to estimate the WFD *average behaviour* for an area. As a minimum, teardown inspection methods should be capable of detecting the minimum size of MSD or MED cracking that would result in a WFD condition (i.e. residual strength degraded below the level specified in CS 25.571(b)). Ideally it is recommended that inspection methods be used that are capable of detecting MSD/MED cracking before it degrades strength below the required level. Effective teardown inspections required to demonstrate freedom from WFD typically require significant resources. They

typically require disassembly (e.g. fastener removal) and destruction of the test article. All areas that are or may be susceptible to WFD should be identified and examined.

(c) *Examples of fatigue test evidence for various types of certification projects.*

The following examples offer some guidance on the types of data sets that might constitute 'sufficient evidence' for some kinds of certification projects. The scope of the test specimen and the duration of the test are considered.

- (1) *New type certificates.* Normally this type of project would necessitate its own full-scale fatigue test of the complete airframe to represent the new structure and its loading environment. Nevertheless, prior full-scale fatigue test evidence from earlier tests performed by the applicant, or others, may also be used and could supplement additional tests on the new model. Ultimately, the evidence needs to be sufficient to conclude with confidence that, within the design service goal of the airframe, widespread fatigue damage will not occur. Factors 1 through 4 should be considered in determining the sufficiency of the evidence.

A test duration of a minimum of twice the design service goal for the aeroplane model would normally be necessary if the loading spectrum is realistic, the design and construction for the test article principal structure is the same as for the certified aeroplane, and the post-test teardown is exhaustive. If the conformance to Factors 1 through 3 is less than ideal, a significantly longer test duration would be needed to conclude with confidence that WFD will not occur within the design service goal. Moreover, no amount of fatigue testing will suffice if the conformance to Factors 1 through 3 above is not reasonable. Consideration should also be given to the possible future need for life extension or product development, such as potential weight increases, etc.

- (2) *Derivative models.* The default position would be to test the entire airframe. However, it may be possible to reliably determine the occurrence of widespread fatigue damage for part or all of the derivative model from the data that the applicant generated or assembled during the original certification project. Nevertheless, the evidence needs to be sufficient to allow confidence in the calculations that show that widespread fatigue damage will not occur within the design service goal of the aeroplane. Factors 1 through 5 should be considered in determining the sufficiency of the evidence for derivative models. For example, a change in the structural design concept, a change in the aerodynamic contour, or a modification of the structure that has a complex internal load distribution might well make analytical extrapolation from the existing full-scale fatigue test evidence very uncertain. Such changes might well necessitate full-scale fatigue testing of the actual derivative principal structure. On the other hand, a typical derivative often involves extending the fuselage by inserting 'fuselage plugs' that consist of a copy of the typical semi-monocoque construction for that model with slightly modified material gauges. Normally this type of project would not necessitate its own full-scale fatigue test, particularly if very similar load paths and operating stress levels are retained.

- (3) *Type design changes — Service bulletins.* Normally this type of project would not necessitate the default option of a full-scale fatigue test

because the applicant would have generated, or assembled, sufficient full-scale fatigue test evidence during the original certification project that could be applied to the change. Nevertheless, as cited in the previous example, the evidence needs to be sufficient to allow confidence in the calculations that show that widespread fatigue damage will not occur within the design service goal of the aeroplane. In addition, Factor 5 'The size and complexity of a design change' should be considered. Therefore, unless otherwise justified, based on existing test data or a demonstration that the design change is not susceptible to WFD, the TCH should perform full-scale tests for the types of design changes listed in Appendix 4.

(4) *Supplemental Type Certificates (STCs)*

Unless otherwise justified according to the guidance below or based on existing test data or a demonstration that the design change is not susceptible to WFD, the applicant for an STC should perform full-scale tests for the types of design changes listed in Appendix 4.

- (i) Sufficient full-scale test evidence for structure certified under an STC may necessitate additional full-scale fatigue testing, although the extent of the design change may be small enough to use Factor 5 to establish the sufficiency of the existing full-scale fatigue test evidence. In addition, although the applicant for an STC may not have access to the original equipment manufacturer's full-scale fatigue test data, they may assume that the basic structure was shown to comply with the regulation, unless EASA has taken, or intends to take, Airworthiness Directive action to alleviate a WFD condition or inspections or modifications exist in the ALS relating to WFD conditions. This assumption implies that sufficient full-scale fatigue test evidence exists, demonstrating that WFD will not occur within the design service goal of the aeroplane. For the purpose of the STC applicant's demonstration, it may be assumed that model types certified under CS 25.571, and which are not subject to Airworthiness Directive action to alleviate a WFD condition, have received two full design service goals of fatigue testing, under realistic loads, and have received a thorough post-test inspection that either did not detect any widespread fatigue damage or the ALS includes from the outset details of modifications required to address WFD. With this knowledge, and Factors 1 through 5, the STC applicant may be able to demonstrate that WFD will not occur on its modification (or the underlying original structure) within the design service goal or a suitably revised value. If, however, the modification significantly affects the distribution of stress in the underlying structure, or significantly alters loads in other parts of the aeroplane, or significantly alters the intended mission for the aeroplane, or if the modification is significantly different in structural concept from the certified aeroplane being modified, additional representative fatigue test evidence would be necessary.
- (ii) In addition, Factor 6 'The age of the aeroplane being modified' comes into play for modifications made to older aeroplanes. The STC applicant should demonstrate freedom from WFD up to the LoV of the aeroplane being modified. For example, an applicant for an STC to an aeroplane that has reached an age equivalent to 75 per cent of its LoV should demonstrate that the modified aeroplane

will be free from WFD for at least the remaining 25 per cent of the LoV. Although an applicant could attempt to demonstrate freedom from WFD for a longer period, this may not be possible unless the original equipment manufacturer cooperates by providing data for the basic structure. A short design service goal for the modification could simplify the demonstration of freedom from WFD for the STC applicant. Nevertheless, the applicant should also be aware that the LoV of the aeroplane is not a fixed life; it may be extended as a result of a structural re-evaluation and service action plan, such as it has been developed for certain models under EASA's & FAA's 'Ageing Aeroplane Programme'. Unless the modifier also re-evaluates its STC modification, the shorter goal for the modification could impede extending the design service goal of the modified aeroplanes.

- (5) *Repairs.* New repairs that differ from the repairs contained in the original equipment manufacturer's structural repair manual, but that are comparable in design to such repairs, and that meet CS-25 in other respects, would not necessitate full-scale fatigue testing to support freedom from WFD up to the LoV. For TCH repairs, only extensive major repair solutions (that may be susceptible to WFD) and that utilise different design concepts from the type design would require further testing.

(d) *Use of existing full-scale fatigue test data*

In some cases, especially for derivative models and type design changes accomplished by the type certificate holder, there may be existing full-scale fatigue test data that may be used to support compliance and mitigate the need to perform additional testing.

Any physical differences between the structure originally tested and the structure being considered that could affect its fatigue behaviour must be identified and reconciled. Differences that should be addressed include, but are not limited to, differences in any of the physical attributes listed under section (b)(1) of this Appendix and differences in operational loading. Typical developments that affect the applicability of the original LoV demonstration data are:

- (1) gross weight (e.g. increases);
- (2) cabin pressurisation (e.g. change in maximum cabin or operating altitude);
- (3) flight segment parameters.

The older the test data, the harder it may be to demonstrate that it is sufficient. Often test articles were not conformed, nor were test plans or reports submitted to EASA as part of the compliance data package. Loading sequence rigor varied significantly over the years and from OEM to OEM. Additionally, testing philosophies and protocols were not standardised. For example, post-test evaluations, if any, varied significantly and in some cases consisted of nothing more than limited visual inspections. However, there may be acceptable data from early full-scale fatigue tests that the applicant proposes to use to support compliance. In order to use such data the configuration of the test article and loading must be verified and the issue of the residual strength capability of the article (or teardown data) at the end of the test must be addressed.

(e) *Use of in-service data.* There may be in-service data that can be used to support WFD evaluations. Examples of such data are as follows:

- Documented positive findings of MSD/MED cracks that include location, size and the time in service of the affected aircraft along with a credible record of how the aircraft had been operated since original delivery.
- Documented negative findings from in-service inspections for MSD/MED cracks on a statistically significant number of aircraft with the time in service of each aircraft and a credible record of how each aircraft had been operated since original delivery. For this data to be useful the inspections methods used should have been capable of detecting MSD/MED crack sizes equal to or smaller than those sizes that could reduce the strength of the structure below the residual strength levels specified in CS 25.571(b).
- Documented findings from the destructive teardown inspection of structure from in-service aircraft. This might be structure (e.g. fuselage splices) removed from aircraft that were subsequently returned to service or from retired aircraft. It would also be necessary to have a credible record of the operational loading experienced by the subject structure up to the time it was taken out of service.

- Prior to using in-service data any physical and loading differences that exist between the structure of the in-service or retired aircraft and the structure being certified should be identified and reconciled as discussed above.

Appendix 3 – Methods for inspection threshold determination

Different approaches have been used to calculate inspection thresholds, although these are essentially variants of one of two methods, viz.

- (a) the fatigue (stress-life or strain-life) method, which uses fatigue endurance data collected under constant stress or constant strain conditions, and a linear damage accumulation model (Palmgren-Miner rule);
- (b) the crack growth method, which uses crack propagation and residual strength data to calculate the growth from an assumed initial crack size to a critical crack length, according to fracture mechanics principles.

CS 25.571(a)(4) requires certain types of structure to have thresholds based upon crack growth analyses or test assuming the maximum probable flaw due to manufacturing or service-induced damage. This approach applies to:

- (a) single load path structure; and
- (b) multiple load path 'fail-safe' structure and crack arrest 'fail-safe' structure, where it cannot be demonstrated that the resulting load path failure or partial failure (including arrested cracks) will be safely detected and repaired during normal maintenance, inspection, or operation of an aeroplane prior to failure of the remaining structure.

Section 8(c) of this AMC provides further details on identifying this structure.

In lieu of other data, an acceptable threshold for inspection for the maximum probable manufacturing flaw may be obtained for aluminium alloy airframe structure if an initial corner crack of radius 0.05' (1.27 mm) is assumed at a single typical fastener hole and the total crack growth life is divided by 2. Whether this approach is also sufficient to conservatively address all probable forms of service-induced damage needs careful consideration and is highly design dependent. Where specific test or service data for service damage exists that can be used to reliably establish an appropriate threshold for all likely types of service damage then crack growth analysis may only need to consider the manufacturing flaw.

For structure susceptible to WFD specific methods for setting inspection thresholds are applicable when agreed to be practical; see Section 11 and Appendix 2 of this AMC.

Regardless of the approach used, the calculated thresholds should be supported with appropriate fatigue test evidence. The best sources of fatigue test evidence are from service experience and large component or full-scale fatigue tests. Large component and full-scale fatigue test specimens are generally constructed using the same manufacturing processes as on the actual aircraft. The results of such tests should provide sufficient information to reliably establish the typical manufacturing quality and possibly its lower bound, especially when those results are combined with service experience. Conversely, simple test specimens used to generate fatigue endurance and crack growth data, which are typically assembled under laboratory or workshop conditions, may not be representative of the actual range of manufacturing quality in the structure under consideration. Therefore, in the absence of information from the full-scale fatigue tests and service experience, consideration should be given to generating fatigue endurance and crack growth data on simple test specimens which include artificial damages that are introduced at the beginning of the test, and are representative of the lower bound of manufacturing quality.

Appendix 4 – Examples of changes that may require full-scale fatigue testing

- (a) The following are examples of types of modifications that may require full-scale fatigue testing:
- (1) passenger-to-freighter conversions (including addition of cargo doors);
 - (2) gross weight increases (e.g. increased operating weights, increased zero-fuel weights, increased landing weights, and increased maximum take-off weights);
 - (3) installation of fuselage cut-outs (e.g. passenger entry doors, emergency exit doors or crew escape hatches, fuselage access doors, and cabin window relocations);
 - (4) complete re-engine or pylon change;
 - (5) engine hush kits;
 - (6) wing modifications (e.g. installation of winglets, changes in flight-control settings such as flap droop, and change of wing trailing-edge structure);
 - (7) modified or replaced skin splice;
 - (8) any modification that affects three or more stiffening members (e.g. wing stringers and fuselage frames);
 - (9) a modification that results in operational-mission change, which significantly changes the original equipment manufacturer's load/stress spectrum (e.g. extending the flight duration from 2 hours to 10 hours); and
 - (10) a modification that changes areas of the fuselage from being externally inspectable using visual means to being inspectable (e.g. installation of a large, external fuselage doubler that results in hiding details beneath it).

Appendix 5 – PSE, FCS, and WFD-susceptible structure

(a) Overview

Four key terms used when showing compliance to the damage tolerance and fatigue requirements of CS-25 and EASA requirements for the continued structural integrity of ageing aircraft are: 'Principal Structural Element (PSE)', 'Fatigue-Critical Structure (FCS)', 'Widespread Fatigue Damage (WFD)-susceptible structure' and 'Design Detail Point (DDP)'.

This Appendix provides clarification on the intended meanings of these terms and how they relate to each other.

(b) Principal Structural Element (PSE)

(1) The term 'Principal Structural Element (PSE)' is defined in this AMC as follows:

Principal Structural Element (PSE) is an element that contributes significantly to the carrying of flight, ground or pressurisation loads, and whose integrity is essential in maintaining the overall integrity of the aircraft.

(2) While this definition does not specifically address the fatigue susceptibility of the structure, or environmental or accidental damage, it is intended to address the majority of the structure that must be evaluated according to CS 25.571. CS 25.571(a) states the following:

'This evaluation must be conducted for each part of the structure that could contribute to a catastrophic failure'.

(3) Examples of PSEs are found in Section 7(f) of this AMC.

(4) The above reinforces the notion that the identification of PSEs should be based solely on the importance of the structure to assure the overall aeroplane integrity.

(5) Section 7(f) of this AMC provides guidance for identifying PSEs. Many manufacturers use this list as a starting point for their list of Fatigue-Critical Structure (FCS). Section 25.571(b) is intended to address all structure that could contribute to a catastrophic failure resulting from fatigue, environmental and accidental damage, and therefore may include some structure that is not considered FCS. Nevertheless, all PSE should be considered when developing a list of FCS.

(6) The definitions used by applicants to identify PSEs have not been consistent among applicants and, in some cases, among models produced by the same applicant. The lack of standardisation of the usage and understanding of the term 'PSE,' and the resulting diversity that exists between type design PSE lists, led authorities to introduce the new term 'Fatigue-Critical Structure (FCS)' in the 'Ageing Aircraft Requirements and Guidance Material'.

(c) Fatigue-Critical Structure (FCS)

(1) In AMC 20-20, 'Fatigue-Critical Structure' is defined as aircraft structure that is susceptible to fatigue cracking, which could contribute to a catastrophic failure. Fatigue-critical structure also includes structure which, if repaired or modified, could be susceptible to fatigue cracking and contribute to a catastrophic failure. Structure is most often susceptible to fatigue cracking when subjected to tension-dominated repeated loads during operation. Such structure may be part of the baseline structure or part of a modification.

'Baseline structure' means structure that is designed under the original type certificate or amended type certificate for that aircraft model (i.e. the as-delivered-aeroplane model configuration).

- (2) Fatigue-critical structure is generally a subset of principal structural elements, specifically those elements that are susceptible to fatigue damage. The exception may be a DDP that is susceptible to fatigue and, although not part of a PSE, could result in catastrophic failure if it were to fail (e.g. an undercarriage door hinge has been categorised by some TCHs as a DDP and FCS, when its failure would lead to loss of the door and the door could impact the aircraft with catastrophic results. In this case the door was not classified as a PSE because the TCH had not considered the door to contribute significantly to carrying flight, ground or pressurisation loads. Considering further aspects of the PSE definition now adopted, it might be claimed that the door is not essential to maintain the overall integrity of the aircraft, i.e. the aircraft may be safe without it. However, due to the need to identify all detail design points and FCS whose failure could cause catastrophic failure of the aircraft it is in any case subject to the fatigue and damage tolerance requirements.)

(d) Detail Design Points (DDP)

'Detail Design Point' is an area of structure that contributes to the susceptibility of the structure to fatigue cracking or degradation such that the structure cannot maintain its load carrying capability, which could lead to a catastrophic failure.

(e) Widespread Fatigue Damage (WFD)-susceptible structure

- (1) 'Widespread Fatigue Damage (WFD)' is the simultaneous presence of cracks at multiple structural locations, which are of sufficient size and density such that the structure no longer meets the residual strength requirements of CS 25.571(b).
- (2) 'Multiple Site Damage (MSD)' and 'Multiple Element Damage (MED)' are conditions that, with no intervention, can lead to WFD. The term 'WFD-susceptible structure' refers to areas of structure that, under normal circumstances, could be expected to eventually develop MSD and/or MED cracks, which could lead to WFD.
- (3) Although not explicitly stated, structure susceptible to WFD cannot be inspected reliably to preclude WFD. Unless a flight cycles and/or flight hours limit is placed on an aeroplane, modifications may be needed to preclude WFD. Structure susceptible to WFD is a subset of FCS, which, in turn, is a subset of PSE.

VI. Draft Decision AMC 20-20

(File attached)

VII. Draft Decision AMC to Part-M

Appendix I to AMC M.A.302 'Content of the Maintenance Programme'

...

1.1.13 If applicable, details of specific structural maintenance programmes where issued by the TC/STC or other approval holders including, but not limited to:

- (a) Damage Tolerance-based Inspection Programmes, such as Supplemental Structural Inspection Programme (SSIP);
- (b) Structural Maintenance Programme resulting from the Service Bulletin Review performed by the TC holders;
- (c) Corrosion Prevention and Control Programme (CPCP);
- (d) Damage Tolerance Evaluation of repairs and modifications, Repair Evaluation Guidelines and Repair Assessment Programmes;
- (e) Maintenance actions arising from the WFD evaluation.

The applicable details of the specific structural maintenance programmes mentioned in subparagraphs (a) to (e) are found in AMC 20-20.

C. Appendices

Appendix I: Definitions and acronyms

AATF11 aeroplanes are the original models considered under the Ageing Aircraft Programme. These were aeroplanes over 75 000 lbs that were at a greater risk for age-related structural problems since they had high number of cycles and they were near or over their design service goal. The list is the following: Airbus 300/Boeing 707/720, Boeing 727, certain Boeing 737s, certain Boeing 747s, McDonald Douglas DC-8, DC-9/MD-80, DC-10, Lockheed L-1011, Fokker F-28 and BAC 1-11.

Damage Tolerance (DT) is the attribute of the structure that permits it to retain its required residual strength without detrimental structural deformation for a period of use after the structure has sustained a given level of fatigue, corrosion, and accidental or discrete source damage.

Damage Tolerance data are Damage Tolerance Evaluation (DTE) documentation and Damage Tolerance Inspections (DTIs).

Damage Tolerance Evaluation (DTE) is a process that leads to the determination of maintenance actions necessary to detect or preclude fatigue cracking that could contribute to a catastrophic failure. As applied to repairs and modifications, a DTE includes the evaluation of the repair or modification and the fatigue-critical structure affected by the repair or modification.

Damage Tolerance Inspections (DTIs) are the inspections developed as a result of a DTE. A DTI includes the areas to be inspected, the inspection method, the inspection procedures (including acceptance and rejection criteria), the threshold, and any repetitive intervals associated with those inspections. DTIs may specify a time limit when a repair or modification needs to be replaced or modified.

Fatigue-Critical Baseline Structure (FCBS) is the baseline structure of the aircraft that is classified as fatigue-critical structure.

Design Approval Holder (DAH) is the holder of any design approval, including type certificate, supplemental type certificate or earlier equivalent or repair approval.

Design Service Goal (DSG) is the period of time in flight hours/cycles/years established at design and/or certification that represents the initially anticipated operational life of the aeroplane, during which the principal structure is expected to be reasonably free from significant cracking.

Fatigue-Critical Structure (FCS) is structure that is susceptible to fatigue cracking that could lead to a catastrophic failure of an aircraft. For the purposes of this AMC, FCS refers to the same class of structure that would need to be assessed for compliance with paragraph 25.571(a) at Amendment 25-45, or later. The term FCS may refer to fatigue-critical baseline structure (**FCBS**), fatigue-critical modified structure (**FCMS**), or both.

Limit of Validity (LoV) is not more than the period of time, stated as a number of total accumulated flight cycles or flight hours or both, for which it has been demonstrated that widespread fatigue damage is unlikely to occur in the aeroplane structure; and that the inspections and other maintenance actions and procedures resulting from this demonstration and other elements of the fatigue and damage tolerance evaluation are sufficient to prevent catastrophic failure of the aeroplane structure.

Primary Structure is structure that carries flight, ground, crash or pressurisation loads.

Repair Evaluation Guidelines (REGs) provide a process to establish damage tolerance inspections for repairs that affect Fatigue-Critical Structure.

Repair Assessment Programme (RAP) is a programme to incorporate damage tolerance-based inspections for repairs to the fuselage pressure boundary structure (fuselage skin, door skin, and bulkhead webs) into the operator's maintenance and/or inspection programme.

Widespread Fatigue Damage (WFD) in a structure is characterised by the simultaneous presence of cracks at multiple structural details that are of sufficient size and density whereby the structure no longer meets the residual strength requirement of CS 25.571(b).

Multiple Site Damage (MSD) is a source of widespread fatigue damage characterised by the simultaneous presence of fatigue cracks in the same structural element.

Multiple Element Damage (MED) is a source of widespread fatigue damage characterised by the simultaneous presence of fatigue cracks in similar adjacent structural elements.

Structural Modification Point (SMP) is the point in time when a structural area must be modified to preclude WFD.

Inspection Start Point (ISP) is the point in time when special inspections of the fleet are initiated due to a specific probability of having an MSD/MED condition.

Acronyms

The following list defines the acronyms that are used in this NPA.

AATF	Airworthiness Assurance Task Force
AAWG	Airworthiness Assurance Working Group
AC	Advisory Circular
AD	Airworthiness Directive(Except for AMC for 25.571 where it is used as Accidental Damage)
ALS	Airworthiness Limitations Section
AMC	Acceptable Means of Compliance
ARAC	Aviation Rulemaking Advisory Committee
ASTM	American Society for Testing and Materials
BSF	Base Scatter Factor
BZI	Baseline Zonal Inspection
CAW	Continuing Airworthiness
CAMO	Continuing Airworthiness Maintenance Organisation
CPCP	Corrosion Prevention and Control Programme
CS	Certification Specification
DAH	Design Approval Holder
DDP	Detail Design Point
DSD	Discrete Source Damage
DSG	Design Service Goal

DT	Damage Tolerance
DTE	Damage Tolerance Evaluation
DTI	Damage Tolerance Inspections and other procedures
EAAWG	European Ageing Aircraft Working Group
EASA	European Aviation Safety Agency (Agency)
ESG	Extended Service Goal
FAA	Federal Aviation Administration
FAR	Federal Aviation Regulation
FCBS	Fatigue-Critical Baseline Structure
FCS	Fatigue-Critical Structure
GSHWG	General Structure Harmonization Working Group
ICA	Instructions for Continued Airworthiness
ISC	Industry Steering Committee
ISP	Inspection Start Point
JAA	Joint Aviation Authorities
JAR	Joint Aviation Regulation
LDC	Large Damage Capability
LoV	Limit of Validity
MED	Multiple Element Damage
MRB	Maintenance Review Board
MRBR	Maintenance Review Board Report
MSD	Multiple Site Damage
MSG	Maintenance Steering Group
MTOW	Maximum Take-Off Weight
NAA	National Aviation Authority
NDI	Non-Destructive Inspection
NTSB	National Transportation Safety Board
OEM	Original Equipment Manufacturer
PSE	Principal Structural Element
RAP	Repairs Assessment Programme
REG	Repair Evaluation Guidelines
SB	Service Bulletin
SMP	Structural Modification Point

SRM	Structural Repair Manual
SSID	Supplemental Structural Inspection Document
SSIP	Supplemental Structural Inspection Programme
STC	Supplemental Type Certificate
STG	Structural Task Group
TC	Type Certificate
TCH	Type Certificate Holder
UERF	Uncontained Engine Rotor Failure
WFD	Widespread Fatigue Damage

Appendix II: Excluded aeroplanes

To maximize the safety benefit and to avoid imposing unnecessary cost for the implementation of the ageing aircraft rule, the following criteria for allowing certain aeroplanes to be excluded from compliance with the ageing aircraft rule for existing designs are proposed.

1. For foreign products, no aeroplanes are operated under the EASA operating requirements and it is unlikely that any will do so in the future, or
2. For foreign products, some aeroplanes are operated under the EASA operating requirements; however, none is foreseen to be operating after the rule compliance date. It is unlikely that any will return to service in the future, or
3. An EU Member State is the State of design, some aeroplanes are operated under the EASA operating requirements or by a foreign carrier; however, none is foreseen to be operating after the rule compliance date. It is unlikely that any will return to service in the future.

Proposals from the stakeholders will be considered by EASA within the NPA public consultation period. The list of excluded aircraft will be included in Appendix I to the implementing rule containing Part-26.

The following aeroplanes are excluded from compliance with Part 26.3xx.

(Reserved)

**AMC 20-20 Amdt 1
Continuing Structural Integrity Programme**

TABLE OF CONTENTS

Paragraph	Title	Page
1	Purpose	89
2	Related regulations and documents	89
3	Background	90
4	Definitions and acronyms	92
5	Continuing Structural Integrity Programme and way of working	94
6	Fatigue and Damage Tolerance Evaluation and Supplemental Structural Inspection Programme (SSIP)	96
7	Continued airworthiness procedures, Service Bulletin review and mandatory modification programme	98
8	Corrosion Prevention and Control Programme (CPCP)	99
9	Damage Tolerance Evaluation of repairs and modifications, Repair Evaluation Guidelines and Repair Assessment Programmes	100
10	Limit of Validity (LoV) of the Structural Maintenance Programme and evaluation for Widespread Fatigue Damage (WFD)	103
11	Supplemental type-certificates and modifications	106
12	Implementation	106
Appendix 1	Guidelines for development of a Supplementary Structural Inspection Programme	108
Appendix 2	Guidelines for development of a programme to preclude the occurrence of Widespread Fatigue Damage	115
Annex 1	Full-scale fatigue test evidence	141
Annex 2	Example on how to establish an LoV	148
Appendix 3	Guidelines for establishing instructions for continued airworthiness of structural repairs and modifications	151
Annex 1	Approval process for new repairs	169
Annex 2	Assessment of existing repairs	170
Annex 3	Repairs and modifications to removable structural components	177
Annex 4	Service Bulletin review process	180
Annex 5	List of significant STCs that may adversely affect fatigue-critical structure	184
Appendix 4	Guidelines for development of a corrosion control programme	185
Appendix 5	Guidelines for the development of an SB review and mandatory modification programme	197

1. PURPOSE

- (a) This Acceptable Means of Compliance (AMC) provides guidance to type-certificate holders, STC holders, repair approval holders, maintenance organisations, operators and competent authorities in developing a continuing structural integrity programme to ensure safe operation of ageing aircraft throughout their operational life, including provision to preclude Widespread Fatigue Damage (WFD).
- (b) This AMC is primarily aimed at large aeroplanes that are operate in Commercial Air Transport or are maintained under Part M. However, this material is also applicable to other aircraft types for operators and TCHs wishing to develop robust continuing structural integrity programmes.
- (c) The means of compliance described in this document provides guidance to supplement the engineering and operational judgement that must form the basis of any compliance findings relative to continuing structural integrity programmes.
- (d) Like all acceptable means of compliance material, this AMC is not in itself mandatory, and does not constitute a requirement. It describes an acceptable means, but not the only means, for showing compliance with the requirements. While these guidelines are not mandatory, they are derived from extensive industry experience in determining compliance with the relevant requirements.
- (e) This revision of the AMC also supports compliance with the latest Part-26 regulations for ageing aircraft structural integrity (Ref. Part 26.300 through 26.370) including Limits of Validity (LoV), WFD evaluation, Damage Tolerance for Repairs and Modifications and structural continued airworthiness programmes.

2. RELATED REGULATIONS AND DOCUMENTS

- (a) Implementing Rules and Certification Specifications:
 - Part 21A.61 Instructions for continued airworthiness-
 - Part 21A.120 Instructions for continued airworthiness-
 - Part 26.300 through 26.360 Rules applicable to DAHs,
 - ~~Part 21A~~
 - Part 21A.433 Repair design
 - Part 26.370 Rules applicable to operators,
 - Part M.A.302 Maintenance programme
 - CS 25.571 Damage tolerance and fatigue evaluation of structure
 - ~~CS 25.903 Engines~~
 - CS 25.1529 Instructions for continued airworthiness
- (b) EASA AMC and FAA Advisory Circulars
 - AMC 25.571 Damage Tolerance and Fatigue Evaluation of Structure
 - AC 91-60 The Continued Airworthiness of Older Airplanes, June 13, 1983, FAA

- AC 91-56AB Continuing Structural Integrity for Large Transport Category Airplanes April Airplanes, March 7, 2008, FAA 29-1998 FAA (and later draft 91-56B)
- AC 20-128A Design Considerations for Minimising Hazards Caused by Uncontained Turbine Engine and Auxiliary Power Unit Rotor Failure, March 25, 1997, FAA.
- AC 120-73 Damage Tolerance Assessment of Repairs to Pressurised Fuselages, FAA. December 14, 2000
- AC 120-93 Damage Tolerance Inspections for repairs and alterations
- AC 120-104 Establishing and implementing Limit of Validity to prevent Widespread Fatigue Damage
- AC 25.1529-1A Instructions for continued airworthiness of structural repairs on Transport Airplanes, FAA, November 20, 2007

(c) Related documents

- 'Recommendations for Regulatory Action to Prevent Widespread Fatigue Damage in the Commercial Aeroplane Fleet', Revision A, dated June 29, 1999 [A report of the Airworthiness Assurance Working Group for the Aviation Rulemaking Advisory Committee Transport Aircraft and Engine Issues.]
- AAWG Final Report on Continued Airworthiness of Structural Repairs, Dec 1996.
- ATA report 51-93-01 structural maintenance programme guidelines for continuing airworthiness, May 1993.
- AAWG Report on Structures Task Group Guidelines, Rev 1 June 1996.
- AAWG Report: Recommendations concerning ARAC taskings FR Doc: 04-10816
Ref.: Aging Airplane safety final rule. 14 CFR 121.370a and 129.16
- Federal Aviation Administration 14 CFR Parts 26, 121, and 129 [Docket No FAA-2005-21693; Amendment Nos 26-1, 121-337, 129-44] Damage Tolerance Data for Repairs and Alterations Final Rule.
- Federal Aviation Administration 14 CFR Parts 25, 26, 121, and 129 [Docket No FAA-2006-24281; Amendment Nos 25-132, 26-5, 121-351, 129-48] Aging Airplane Program: Widespread Fatigue Damage Final Rule.

3. BACKGROUND

Service experience has shown there is a need to have continuing updated knowledge on the structural integrity of aircraft, especially as they become older, to ensure they continue to meet the level of safety intended by the certification requirements. The continued structural integrity of aircraft is of concern because such factors as fatigue cracking and corrosion are time-dependent, and our knowledge about them can best be assessed based on real-time operational experience and the use of the most modern tools of analysis and testing.

In April 1988, a high-cycle transport aeroplane en-route from Hilo to Honolulu, Hawaii, suffered major structural damage to its pressurised fuselage during flight. This accident was attributed in part to the age of the aeroplane involved. The

economic benefit of operating certain older technology aeroplanes has resulted in the operation of many such aeroplanes beyond their previously expected retirement age. Because of the problems revealed by the accident in Hawaii and the continued operation of older aircraft, both the competent authorities and industry generally agreed that increased attention needed to be focused on the ageing fleet and on maintaining its continued operational safety.

In June 1988, the FAA sponsored a conference on ageing aircraft. As a result of that conference, an ageing aircraft task force was established in August 1988 as a sub-group of the FAA's Research, Engineering, and Development Advisory Committee, representing the interests of the aircraft operators, aircraft manufacturers, regulatory authorities, and other aviation representatives. The task force, then known as the Airworthiness Assurance Task Force (AATF), set forth five major elements of a programme for keeping the ageing fleet safe. For each aeroplane model in the ageing transport fleet these elements consisted of the following:

- (a) select service bulletins describing modifications and inspections necessary to maintain structural integrity;
- (b) develop inspection and prevention programmes to address corrosion;
- (c) develop generic structural maintenance programme guidelines for ageing aeroplanes;
- (d) review and update the Supplemental Structural Inspection Documents (SSID) which describe inspection programmes to detect fatigue cracking; and
- (e) assess damage tolerance of structural repairs.

Subsequent to these five major elements being identified, it was recognised that an additional factor in the Aloha accident was widespread fatigue cracking. Regulatory and industry experts agreed that, as the transport aircraft fleet continues to age, eventually Widespread Fatigue Damage (WFD) is inevitable. Therefore the FAA determined, and the EASA concurred, that an additional major element of WFD¹ must be added to the ageing aircraft programme. Structures Task Groups sponsored by the Task Force were assigned the task of developing these elements into usable programmes. The Task Force was later re-established as the AAWG of the ARAC. Although there was JAA membership and European operators and industry representatives participated in the AAWG, recommendations for action focused on FAA operational rules which are not applicable in Europe. It was therefore decided to establish the EAAWG on this subject to implement ageing aircraft activities into the Agency's regulatory system, not only for the initial 'AATF eleven' aeroplanes, but also other old aircraft and more recently certified ones. EAAWG recommendations and the development of EASA and new regulations led to the current format of Part-M for continuing airworthiness, associated maintenance programme requirements and to the inclusion of ageing aircraft structures programmes into the AMC Part-M (M.A.302). AMC 20-20 is a major part of the European adoption and adaptation of the AAWG internationally developed recommendations which it follows as closely as practicable.

It is acknowledged that the various competent authorities, type certificate holders and operators have continually worked to maintain the structural integrity of older aircraft on an international basis. This has been achieved through an exchange of in-service information, subsequent changes to inspection programmes and by the development and installation of modifications on particular aircraft. However, it is evident that with the increased use, longer operational lives and experience from in-service aircraft, there is a need for a programme to ensure a high level of structural integrity for all aircraft, and in particular those in the transport fleet.

Accordingly, the inspection and evaluation programmes outlined in this AMC are intended to provide:

- a continuing structural integrity assessment by each type certificate holder, and
- the incorporation of the results of each assessment into the maintenance programme of each operator.

This revision to the AMC supports the latest EASA rulemaking on ageing aircraft structures that includes requirements for various design approval holders to develop certain data and ICA if they have not already done so and make it available to operators. Furthermore, operators in addition to implementing these new ICA as envisaged under Part-M are required by Part 26 to ensure that approved damage tolerance-based inspections are obtained and implemented on all repairs and modifications on aircraft certified for 30 pax or more or for 7 500 lbs or more payload.

4. DEFINITIONS AND ACRONYMS

(a) For the purposes of this AMC, the following definitions apply:

- **Damage Tolerance (DT)** is the attribute of the structure that permits it to retain its required residual strength without detrimental structural deformation for a period of use after the structure has sustained a given level of fatigue, corrosion, and accidental or discrete source damage.
- **Design Approval holder (DAH)** is the holder of any design approval, including type certificate, supplemental type certificate or earlier equivalent, or repair approval.
- **Design Service Goal (DSG)** is the period of time in flight hours/cycles/years, established at design and/or certification that represents the initially anticipated operational life of the aeroplane, during which the principal structure is expected to be reasonably free from significant cracking including widespread fatigue damage.
- **Existing design changes or repairs** are changes and repairs which are to be approved before the entry into force of this rule.
- **Fatigue-Critical Structure (FCS)** is structure that is susceptible to fatigue cracking that could lead to a catastrophic failure of an aircraft. For the purposes of this AMC, FCS refers to the same class of structure that would need to be assessed for compliance with § 25.571(a) at Amendment 25-45, or later. The term FCS may refer to fatigue-critical baseline structure, fatigue-critical modified structure, or both.
- **Inspection Start Point (ISP)** is the point in time when special inspections of the fleet are initiated due to a specific probability of having an MSD/MED condition.
- **Future design changes and repairs** are changes and repairs which are to be approved on or after the entry into force of this rule.

- **Limit of Validity (LoV)** is not more than the period of time, expressed in appropriate units (e.g. flight cycles) stated as a number of total accumulated flight cycles or flight hours or both, for which it has been shown that the established inspections and replacement times will be sufficient to allow safe operation and in particular to preclude development of demonstrated that widespread fatigue damage is unlikely to occur in the aeroplane structure; and that the inspections and other maintenance actions and procedures resulting from this demonstration and other elements of the fatigue and damage tolerance evaluation are sufficient to prevent catastrophic failure of the aeroplane structure.
- **Multiple Element Damage (MED)** is a source of widespread fatigue damage characterised by the simultaneous presence of fatigue cracks in similar adjacent structural elements.
- **Multiple Site Damage (MSD)** is a source of widespread fatigue damage characterised by the simultaneous presence of fatigue cracks in the same structural element. (i.e. fatigue cracks that may coalesce with or without other damage leading to a loss of required residual strength).
- **Primary Structure** is structure that carries flight, ground, crash or pressurisation loads.
- **Published repair data** are instructions for accomplishing repairs which are published for general use in structural repair manuals and Service Bulletins (or equivalent types of documents).
- **Repair Evaluation Guidelines (REG)** provide a process to establish damage tolerance inspections for repairs that affect Fatigue-Critical Structure.
- **Repair Assessment Programme (RAP)** is a programme to incorporate damage tolerance-based inspections for repairs to the fuselage pressure boundary structure (fuselage skin, door skin, and bulkhead webs) into the operator's maintenance and/or inspection programme.
- **Structural Modification Point (SMP)** is the point in time when a structural area must be modified to preclude WFD.
- **Widespread Fatigue Damage (WFD)** in a structure is characterised by the simultaneous presence of cracks at multiple structural details that are of sufficient size and density whereby the structure will no longer meet its damage tolerance requirements (i.e., to maintain its required residual strength after partial structural failure) the applicable residual strength requirements (e.g. JAR 25.571 (b), CS 25.571(b)).

(b) The following list defines the acronyms that are used throughout this AMC:

AAWG	Airworthiness Assurance Working Group
AC	Advisory Circular
AD	Airworthiness Directive
ALS	Airworthiness Limitations Section

AMC	Acceptable Means of Compliance
ARAC	Aviation Rulemaking Advisory Committee
BZI	Baseline Zonal Inspection
CPCP	Corrosion Prevention and Control Programme
CS	Certification Specification
DAH	Design Approval holder
DSD	Discrete Source Damage
DSG	Design Service Goal
DT	Damage Tolerance
DTE	Damage Tolerance Evaluation
DTI	Damage Tolerance Inspections and other procedures
EAAWG	European Ageing Aircraft Working Group
EASA	European Aviation Safety Agency
ESG	Extended Service Goal
FAA	Federal Aviation Administration
FAR	Federal Aviation Regulation
FCBS	Fatigue-Critical Baseline Structure
FCS	Fatigue-Critical Structure
ICA	Instructions for Continued Airworthiness
ISP	Inspection Start Point
JAA	Joint Aviation Authorities
JAR	Joint Aviation Regulation
LDC	Large Damage Capability
LoV	Limit of Validity
MED	Multiple Element Damage
MRB	Maintenance Review Board
MSD	Multiple Site Damage
MSG	Maintenance Steering Group
NAA	National Aviation Authority
NDI	Non-Destructive Inspection
NTSB	National Transportation Safety Board
PSE	Principal Structural Element
RAP	Repairs Assessment Programme
REG	Repair Evaluation Guidelines
SB	Service Bulletin
SMP	Structural Modification Point
SRM	Structural Repair Manual
SSID	Supplemental Structural Inspection Document
SSIP	Supplemental Structural Inspection Programme
STG	Structural Task Group
TCH	Type Certificate Holder
WFD	Widespread Fatigue Damage

5. CONTINUING STRUCTURAL INTEGRITY PROGRAMME AND WAY OF WORKING

(a) General

Part 26.300(f) 'Continued Airworthiness Procedures' requires that TCHs for large aeroplanes establish a new process or validate an existing process which ensures that unsafe levels of fatigue cracking will be precluded in service.

These new or validated procedures and processes must include periodic monitoring of operational usage with comparison to design assumptions.

The programmes and processes described in this and subsequent paragraphs of this AMC are all part of an acceptable process to provide a continuing structural integrity programme that precludes unsafe levels of cracking.

The monitoring of operational usage is best achieved in cooperation with the operators, including implementation of fleet leader programmes to ensure that flight lengths, fuel weights, payloads, altitudes, etc., correspond with the assumptions made when the aircraft was certified or that were used in the development of the ageing aircraft programmes. Where data does not correspond to the original assumptions its potential impact on all ageing aircraft structural programmes and CAW in general must be considered. For a large transport aeroplane in commercial air transport it should be sufficient to review the operational data at 5-year intervals. Obvious changes to usage should be addressed for their impact on fatigue and damage tolerance and when they occur. In particular, aircraft use for conducting surveys, commercial or non-commercial operations should be considered on a case-by-case basis.

In order to show compliance with Part 26.300(f) 'Continued Airworthiness Procedures' the TCH's procedures that address Part 26.300(f) and take into account the guidance of this AMC should be provided to the Agency (see Appendix 5 for further details). For non-EU TCHs, where a bilateral exists, a summary of the TCH's procedures will normally suffice and a recommendation will be requested from the foreign authority responsible for the TCH that those procedures assure compliance with Part 26.300(f).

Furthermore, as part of this process, the assumptions made for fatigue, accidental and environmental damage scenarios during certification should on a regular basis be validated against service experience to see if they remain applicable.

All the ageing aircraft programme elements discussed in this AMC benefit from cooperation between operators and TCHs. The use of Structural Task Groups (STGs) has historically proved very successful in this regard and is recommended.

On the initiative of the TCH and the Agency, a STG should be formed for each aircraft model for which it is decided to put in place an ageing aircraft programme. The STG shall consist of the TCH, selected operator members and Agency representative(s). The objective of the STG is to complete all tasks covered in this AMC in relation to their respective model types, including the following:

- develop model-specific programmes,
- define programme implementation,
- conduct recurrent programme reviews as necessary.

It is recognised that it might not always be possible to form or to maintain an STG, due to a potential lack of resources with the operators or TCH. In this case the above objective would remain with the Agency and operators or TCH as applicable.

An acceptable way of working for STGs is described in the 'Report on Structures Task Group Guidelines' that was established by the AAWG with the additional clarifications provided in the following sub-paragraphs.

(b) Meeting scheduling

It is the responsibility of the TCH to schedule STG meetings. However, if it is found by the Agency that the meeting scheduling is inadequate to meet the STG working objectives, the Agency might initiate itself additional STG meetings.

(c) Reporting

The STG would make recommendations for actions via the TCH to the Agency. Additionally, the STG should give periodic reports (for information only) to AAWG/Agency as appropriate with the objective of maintaining a consistent approach.

(d) Recommendations and decision making

The decision making process described in the AAWG Report on Structures Task Group Guidelines paragraph 7 leads to recommendations for mandatory action from the TCH to the Agency. In addition it should be noted that the Agency is entitled to mandate safety measures related to ageing aircraft structures, in addition to those recommended by the STG, if it finds it necessary.

(e) Responsibilities

- (1) The TCH is responsible for developing the ageing aircraft structures programme for each aircraft type, detailing the actions necessary to maintain airworthiness. Other DAH should develop programmes or actions appropriate to the modification/repair for which they hold approval, unless addressed by the TCH. All DAHs will be responsible for monitoring the effectiveness of their specific programme, and to amend the programme as necessary.
- (2) The operator is responsible for incorporating approved DAH actions necessary to maintain airworthiness into its aircraft-specific maintenance programmes, in accordance with Part-M (Ref. M.A.302).
- (3) The competent authority of the State of registry is responsible for the approval of the aircraft maintenance programme.
- (4) The Agency will approve ageing aircraft structures programmes and may issue ADs to support implementation, where necessary, e.g. where the Agency assumes the responsibilities of the State of design. However, it is intended that Part-M and where necessary Part-26 requirements will be the means of implementation of ageing aircraft programmes in European registered aircraft. The Agency, in conjunction with the DAH, will monitor the overall effectiveness of ageing aircraft structures programmes.

6. FATIGUE AND DAMAGE TOLERANCE EVALUATION AND SUPPLEMENTAL STRUCTURAL INSPECTION PROGRAMME (SSIP)

Aircraft certified to JAR 25 Change 7 or later and FAR 25 Amdt 54 or later are provided with an Airworthiness Limitations Section (ALS) that includes damage tolerance-based inspections. Many aircraft certified to earlier amendments have also been provided with a DT-based ALS.

Part 26.300(a) requires that TCHs for certain large transport aeroplanes create an ALS and include in it inspections and other procedures derived from a fatigue and damage tolerance evaluation. An SSID or ALS developed according to the guidance of this AMC or an SSID mandated under a current EASA Airworthiness Directive will satisfy the requirements of Part 26.300(b). In the absence of an approved damage tolerance-based structural maintenance inspection programme (e.g. MRB report, ALS) and associated SSID or ALS, the TCH, in conjunction with operators, is expected to initiate the development of an SSIP for each aircraft model. Such a programme must be implemented before analysis, tests, and/or service experience indicates that a significant increase in inspection and/or modification is necessary to maintain structural integrity of the aircraft. This should ensure that an acceptable programme is available to the operators when needed. The programme should include procedures for obtaining service information, and assessment of service information, available test data, and new analysis and test data. An SSID should be developed, as outlined in Appendix 1 to of this AMC, from this body of data. The role of the operator is principally to comment on the practicality of the inspections and any other procedures defined by the TCH and to implement them effectively.

The SSID or ALS, along with the criteria used and the basis for the criteria should be submitted to the Agency for review and approval. The SSIP should be adequately defined in the SSID. The SSID or ALS should include inspection threshold, repeat interval and inspection methods. The applicable modification status, associated life limitation and types of operations for which the SSID is valid should also be identified and stated. For an aircraft maintenance programme subject to an LoV under Part 26.300(c) the evaluation need only provide the inspections and other procedures necessary up to the LoV. For other aeroplanes for which a DTE is necessary, all inspections and other procedures must be provided that are anticipated to be applicable throughout the operational life of the aeroplane to prevent catastrophic failure due to fatigue. Unless the ALS provides a limitation on the applicability of the maintenance programme, the programme must be shown to address the maximum potential usage of the aeroplane based on experience with similar products or a conservative assumption. Consideration must be given to the advisory material applicable to the amendment of FAR or JAR or CS 25.571 contained in the certification basis when determining if fail-safety and inspections alone are a practical means to assure continued airworthiness. For an SSIP newly developed to meet Part 26.300 the guidance of this AMC applies. In addition, the inspection access, the type of damage being considered, likely damage sites and details of the resulting fatigue cracking scenario should be included as necessary to support the prescribed inspections.

The Agency's review of the SSID will include both engineering and maintenance aspects of the proposal. Because the SSID is applicable to all operators and is intended to address potential safety concerns on older aircraft, the Agency expects these essential elements to be included in maintenance programmes developed in compliance with Part-M. In addition, the Agency will issue ADs to implement any Service Bulletins or other service information publications found to be essential for safety during the initial SSID assessment process should the SSID not be available in time to effectively control the safety concern. Service Bulletins or other service information publications revised or issued as a result of in-service findings resulting from implementation of the SSID should be added to the SSID or will be implemented by separate AD action, as appropriate.

In the event an acceptable SSID cannot be obtained on a timely basis, the Agency may impose service life, operational, or inspection limitations to assure structural integrity.

As a result of a periodic review, the TCH should revise the SSID whenever additional information shows a need. The original SSID will normally be based on predictions or assumptions (from analyses, tests, and/or service experience) of failure modes, time to initial damage, frequency of damage, typically detectable damage, and the damage growth period. Consequently, a change in these factors sufficient to justify a revision would have to be substantiated by test data or additional service information. Any revision to SSID criteria and the basis for these revisions should be submitted to the Agency for review and approval of both engineering and maintenance aspects.

7. CONTINUED AIRWORTHINESS PROCEDURES, SERVICE BULLETIN REVIEW AND MANDATORY MODIFICATION PROGRAMME

Service Bulletins issued early in the life of an aircraft fleet may utilise inspections (in some cases non-mandatory inspections) alone to maintain structural integrity. Inspections may be adequate in this early stage, when cracking is possible, but not highly likely. However, as aircraft age the probability of fatigue cracking becomes more likely. In this later stage it is not prudent to rely only on inspections alone because there are more opportunities for cracks to be missed and cracks may no longer occur in isolation. In this later stage in the life of a fleet it is prudent to reduce the reliance strictly on inspections, with its inherent human factors limitations, and incorporate modifications to the structure to eliminate the source of the cracking. In some cases reliance on an inspection programme, in lieu of modification, may be acceptable through the increased use of mandatory versus non-mandatory inspections.

The TCH, in conjunction with operators, is expected to initiate a review of all structurally related inspection and modification SBs and determine which require further actions to ensure continued airworthiness, including mandatory modification action or enforcement of special repetitive inspections.

Any aircraft primary structural components that would require frequent repeat inspection, or where the inspection is difficult to perform, taking into account the potential airworthiness concern, should be reviewed to preclude the human factors issues associated with repetitive inspections.

Part 26.300(f) requires that Continued Airworthiness Procedures are established or validated to ensure that unsafe levels of fatigue cracking will be precluded in service. These new or validated procedures and processes must include:

- (a) periodic monitoring of operational usage with comparison to design assumptions;
- (b) a periodic Service Bulletin review process or equivalent that includes an assessment of the need for mandatory changes in cases where inspection alone is not reliable enough to ensure that unsafe levels of cracking are precluded.

Compliance may take into account compliance with this subpart and compliance with previous programmes of SB review, etc.

Significant environmental and accidental damage findings should also be taken into account. Damage scenarios assumed for certification should be compared to those being reported (leading to SB action) and where there are differences, the potential

airworthiness impact should be evaluated. Differences may include the pattern and extent of cracking, corrosion or accidental damage, the time at which it was discovered and the rate of growth.

The SB review is an iterative process consisting of the following items:

- (a) The TCH should review all issued structural inspection and modification SBs to select candidate bulletins, using the following 4 four criteria:
 - (i) There is a high probability that structural cracking exists.
 - (ii) Potential structural airworthiness concern.
 - (iii) Damage is difficult to detect during routine maintenance. (Of particular concern is damage that is found when well developed and closer to being critical rather than in the early stages with several further opportunities available for detection before becoming critical.)
 - (iv) There is adjacent structural damage or the potential for it.

This may be done by the TCH alone or in conjunction with the operators at a preliminary STG meeting.

Each of the criteria should be addressed on a routine basis, also considering new information about operational usage when it becomes available from the monitoring programme.

- (b) The TCH and operator members will be requested to submit information on individual fleet experience relating to candidate SBs. This information will be collected and evaluated by the TCH. The summarised results will then be reviewed in detail at an STG meeting (see point (c) below).
- (c) The final selection of SBs for recommendation of the appropriate corrective action to assure structural continued airworthiness taking into account the in-service experience, will be made during an STG meeting by the voting members of the STG, either by consensus or majority vote, depending on the preference of the individual STGs.
- (d) An assessment will be made by the TCH as to whether or not any subsequent revisions to SBs affect the previous decision made. Any subsequent revisions to SBs previously chosen by the STG for mandatory inspection or incorporation of modification action that would affect the previous STG recommended action should be submitted to the STG for review.
- (e) The TCH should review all new structural SBs periodically to select further candidate bulletins. The TCH should schedule a meeting of the STG to address the candidates.

More guidance on the SB review and Continued Airworthiness Procedures for airframe structure is provided in Appendix 5.

Operator members and the competent authority will be advised of the candidate selection and provided with the opportunity to submit additional candidates.

8. CORROSION PREVENTION AND CONTROL PROGRAMME

A corrosion prevention and control programme (CPCP) is a systematic approach to prevent and to control corrosion in the aircraft's primary structure. The objective of

a CPCP is to limit the deterioration due to corrosion to a level necessary to maintain airworthiness and where necessary to restore the corrosion protection schemes for the structure. A CPCP consists of a basic corrosion inspection task, task areas, defined corrosion levels, and compliance times (implementation thresholds and repeat intervals). The CPCP also includes procedures to notify the competent authority and TCH of the findings and data associated with Level 2 and Level 3 corrosion and the actions taken to reduce future findings to Level 1 or better. See Appendix 4 for definitions and further details.

As part of the ICA, the TCH should provide an inspection programme that includes the frequency and extent of inspections necessary to provide the continued airworthiness of the aircraft. Furthermore, the ICA should include the information needed to apply protective treatments to the structure after inspection. In order for the inspections to be effectively accomplished, the TCH should provide corrosion removal and cleaning procedures and reference allowable limits (e.g. SRM). The TCH should include all of these corrosion-related activities in a manual referred to as the Baseline Programme. This Baseline Programme manual is intended to form a basis for operators to derive a systematic and comprehensive CPCP for inclusion in the operator's maintenance programme. The TCH is responsible for monitoring the effectiveness of the Baseline Programme and, if necessary, to recommend changes based on operators reports of findings. In line with Part-M requirements, when the TCH publishes revisions to their Baseline Programme, these should be reviewed and the operator's programme adjusted as necessary in order to maintain corrosion to Level 1 or better.

An operator may adopt the Baseline Programme provided by the TCH or it may choose to develop its own CPCP, or may be required to if none is available from the TCH. In developing its own CPCP an operator may join with other operators and develop a Baseline Programme similar to a TCH-developed Baseline Programme for use by all operators in the group.

Before an operator may include a CPCP in its maintenance or inspection programme, the competent authority should review and approve that CPCP. The operator should show that the CPCP is comprehensive in that it addresses all corrosion likely to affect primary structure, and is systematic in that it provides:

- (a) step-by-step procedures that are applied on a regular basis to each identified task area or zone, and
- (b) these procedures are adjusted when they result in evidence that corrosion is not being controlled to an established acceptable level (Level 1 or better).

Note: For an aeroplane with an ALS, in addition to providing a suitable baseline programme in the ICA, it is appropriate for the TCH to place an entry in the ALS stating that all corrosion should be maintained to Level 1 or better. (This practice is also described in ATA MSG-3.)

9. DAMAGE TOLERANCE EVALUATION OF REPAIRS AND MODIFICATIONS, REPAIR EVALUATION GUIDELINES AND REPAIR ASSESSMENT PROGRAMMES

Early fatigue or fail-safe requirements (pre-Amdt 45) did not necessarily provide for timely inspection of critical structure so that damaged or failed components could be dependably identified and repaired or replaced before a hazardous condition developed. Furthermore, it is known that application of later fatigue and damage tolerance requirements to repairs was not always fully implemented according to the relevant certification bases.

Repair Evaluation Guidelines (REG) are intended to assure the continued structural integrity of all relevant repaired and adjacent structure, based on damage tolerance principles, consistent with the safety level provided by the SSID or ALS as applied to the baseline structure. To achieve this, the REG should be developed by the TCH and implemented by the operator to ensure that an evaluation is performed of all repairs to structure that is susceptible to fatigue cracking and could contribute to a catastrophic failure.

Even the best maintained aircraft will accumulate structural repairs when being operated. The AAWG conducted two separate surveys of repairs placed on aircraft to collect data. The evaluation of these surveys revealed that 90 % of all repairs found were on the fuselage, hence these are a priority and RAPs have already been developed for the fuselage pressure shell of many large transport aeroplanes not originally certificated to damage tolerance requirements. 40 % of the repairs were classified as adequate and 60 % of the repairs required consideration for possible additional supplemental inspection during service. Nonetheless, following further studies by the AAWG working groups it has been agreed that repairs to all structure susceptible to fatigue and whose failure could contribute to catastrophic failure will be considered. (Ref. AAWG Report: Recommendations concerning ARAC taskings FR Doc: 04-10816 Ref: Aging Airplane safety final rule. 14 CFR 121.370a and 129.16.)

As aircraft operate into high cycles and high times the ageing repaired structure needs the same considerations as the original structure in respect of damage tolerance. Existing repairs may not have been assessed for damage tolerance and appropriate inspections or other actions implemented. Repairs are to be assessed, replaced if necessary or repeat inspections determined and carried out as supplemental inspections or within the baseline zonal inspection programme. A damage tolerance-based inspection programme for repairs will be required to detect damage which may develop in a repaired area, before that damage degrades the load carrying capability of the structure below the levels required by the applicable airworthiness standards.

Part 26.320 requires TCHs of aeroplanes with 30 pax or more or having a payload of 3401,9 kg (7 500 lbs) or more to develop a REG and submit it for approval to the Agency.

The REG should provide data to address repairs to all structure that is susceptible to fatigue cracking and could contribute to a catastrophic failure. The REG may refer to the RAP, other existing approved data such as SRM and SBs or provide specific means for obtaining data for individual repairs.

In accordance with Part 26.320, documentation including existing published repair data, such as the Structural Repair Manual and Service Bulletins, need to be reviewed for compliance with damage tolerance principles and be updated and promulgated consistent with the intent of the REGs.

This fatigue and damage tolerance evaluation of repairs will establish an appropriate inspection programme or a replacement schedule if the necessary inspection programme is too demanding or not possible. Details of the means by which the REGs and the maintenance programme may be developed are incorporated in Appendix 3 of this AMC.

Part 26.370 directs the operator and organisations responsible for the maintenance of large aeroplanes to revise their maintenance programmes to address the potential adverse effects of repairs and modifications to fatigue-critical structure. The primary vehicle for achieving this for repairs will be the REG supplied by the TCH and for modifications the data supplied by the DAH; again further guidance is provided in Appendix 3 to this AMC.

Once a REG has been implemented on an aircraft, all subsequent (future) repairs should also be evaluated for damage tolerance and provided with inspections and other procedures as necessary. Part 26.320, 26.330 and 26.360 ensure as far as possible that appropriate data is available for all repairs from the DAH.

10. LIMIT OF VALIDITY OF THE MAINTENANCE PROGRAMME AND EVALUATION FOR WIDESPREAD FATIGUE DAMAGE

(a) Initial WFD evaluation and LoV

All fatigue and damage tolerance evaluations are finite in scope and also therefore in their long-term ability to ensure continued airworthiness. The maintenance requirements that evolve from these evaluations have a finite period of validity defined by the extent of testing, analysis and service experience that make up the evaluation and the degree of associated uncertainties. The **Limit of Validity (LoV)** is the period of time, expressed in appropriate units (e.g. flight cycles) for which it has been shown that the established inspections and replacement times will be sufficient to allow safe operation and in particular to preclude development of widespread fatigue damage. The LoV should be based on fatigue test evidence. of the engineering data that supports the structural maintenance programme is defined as being not more than the period of time, stated as a number of total accumulated flight cycles or flight hours or both, for which it has been demonstrated that widespread fatigue damage is unlikely to occur in the aeroplane structure; and that the inspections and other maintenance actions and procedures resulting from this demonstration and the other elements of the fatigue and damage tolerance evaluation, are sufficient to prevent catastrophic failure of the aeroplane structure. To support establishment of the LoV, the design approval holder will demonstrate by test evidence, analysis and, if available, service experience and teardown inspection results of high-time aeroplanes, that WFD is unlikely to occur in that aeroplane up to the LoV.

The likelihood of the occurrence of fatigue damage in an aircraft's structure increases with aircraft usage. The design process generally establishes a design service goal (DSG) in terms of flight cycles/hours for the airframe. It was generally expected when fatigue and fail-safe rules were first developed that any cracking that occurs on an aircraft operated up to the DSG will occur in isolation (i.e., local cracking), originating from a single source, such as a random manufacturing flaw (e.g. a mis-drilled fastener hole) or a localised design detail. It is considered unlikely that cracks from manufacturing flaws or localised design issues will interact strongly as they grow. The SSIP described in paragraph 6 and Appendix 1 to of this AMC were intended to find all forms of fatigue damage before they become critical. Nonetheless, it has become apparent that as aircraft have approached and exceeded their DSG only some SSIPs have correctly addressed Widespread Fatigue Damage (WFD) as described below.

It should be noted that the majority of aircraft in the European fleet are now damage tolerance certified and that the JAR and CS damage tolerance requirements have always required consideration of all forms of fatigue damage.

JAR 25.571 at Change 7 stated:

(b) Damage tolerance (fail-safe) evaluation.

The evaluation must include a determination of the probable locations and modes of damage due to fatigue, corrosion, or accidental damage. The determination must be by analysis supported by test evidence and (if available) service experience. Damage at multiple sites due to prior fatigue exposure must be included where the design is such that this type of damage can be expected to occur.

AMC 25.571(a), (b) and (e) stated in Section 2.1.1.:

d. Provisions to limit the probability of concurrent multiple damage, particularly after long service, which could conceivably contribute to a common fracture path.

The achievement of this would be facilitated by ensuring sufficient life to crack initiation.

Examples of such multiple damage are –

- i. A number of small cracks which might coalesce to form a single long crack;
- ii. Failures, or partial failures, in adjacent areas, due to the redistribution of loading following a failure of a single element; and
- iii. Simultaneous failure, or partial failure, of multiple load path discrete elements, working at similar stress levels.

In practice it may not be possible to guard against the effects of multiple damage and failsafe substantiation may be valid only up to a particular life which would preclude multiple damage.'

Nonetheless, it is not clear, even for later aircraft that all applicants followed this guidance, hence the development of the EASA ageing aircraft requirements.

WFD may originate in two basic forms, either as Multiple Site Damage (MSD) or as Multiple Element Damage (MED). With extended usage, uniformly loaded structure may develop cracks in adjacent fastener holes (MSD), or in adjacent similar structural details (MED). The development of cracks at multiple locations (both MSD and MED) may also result in strong interactions that can affect subsequent crack growth, in which case the predictions for local cracking would no longer apply. An example of this situation may occur at any skin joint where load transfer occurs. Simultaneous cracking at many fasteners along a common rivet line may reduce the residual strength of the joint below required levels before the cracks are detectable under the maintenance programme established at time of certification. Furthermore, these cracks, while they may or may not interact, can have an adverse effect on the large damage capability (LDC) of the airframe before the cracks become detectable.

Part 26.300(d) requires TCHs of large transport aeroplanes of MTOM greater than 34 019 kg (75 000 lbs) to establish actions upon which the LoV is dependent. However, the principles described here are applicable to any aircraft that has structural features susceptible to WFD and/or for which the engineering data that supports the maintenance programme is limited. The TCH's role is to perform a WFD evaluation and develop all necessary maintenance actions including modifications, replacement times and inspections that support the LoV, with the intent of precluding operation with WFD. The TCH's role is to perform a WFD evaluation and, in conjunction with operators, is expected to initiate development of a maintenance programme with the intent of precluding operation with WFD. Appendix 2 provides guidelines for development of a programme to preclude the occurrence of WFD. Such a programme must be implemented before analysis, tests, and/or service experience indicates that widespread fatigue damage WFD may develop in the fleet. The operator's role is to provide service experience, to help ensure the practicality of the programme and to ensure it is implemented effectively.

The proposed LoV and results of the WFD evaluation should be presented for review and approval to the Agency for the aircraft model being considered. Since the objective of this evaluation is to preclude WFD from the fleet, it is expected that the results will include recommendations for necessary inspections or modification and/or replacement of structure, as appropriate to support the LoV. It is expected that the TCH will work closely with operators in the development of these programmes to assure that the expertise and resources are available when implemented.

Note: The LoV applies to aeroplanes, not to individual parts. Should there be any concerns about the service life of a removable component containing FCS or PSEs, an ALS limitation or SMP can be mandated on that specific component, which would then need to be tracked.

The Agency's review of the WFD evaluation results will include both engineering and maintenance aspects of the proposal. Per Appendix I to AMC M.A.302 and Part 26.370, any actions necessary to preclude WFD, including the LoV, are to be incorporated in the maintenance programmes developed in compliance with Part-M. Any Service Bulletins or other service information publications revised or issued as a result of in-service MSD/MED findings resulting from implementation of these programmes may require separate AD action.

In the event an acceptable WFD evaluation cannot be completed on a timely basis, the Agency may impose service life, operational, or inspection limitations to assure structural integrity of the subject type design.

(b) Revision of WFD evaluation and LoV

New service experience findings, improvements in the prediction methodology, better load spectrum data, a change in any of the factors upon which the WFD evaluation is based or economic considerations, may dictate a revision to the evaluation. Accordingly, associated new recommendations for service action should be developed including a revised LoV, if appropriate, and submitted to the Agency for review and approval of both engineering and maintenance aspects.

In order to operate an individual aircraft up to an extended LoV, a WFD evaluation should also be performed for all applicable modified or repaired structure to determine if any new structure or any structure affected by the change is susceptible to WFD. This evaluation should be conducted by the DAH for the changed structure in conjunction with the operator prior to the aircraft reaching its existing LoV. For practical purposes it is suggested that the SRM is also reviewed and updated to facilitate its continued applicability up to the extended LoV. If this is not done all SRM-based repairs will require individual approval. The results together with any necessary actions required to preclude WFD from occurring before the aircraft reaches the revised LoV should be presented for review and approval by the Agency.

This process may be repeated such that, subject to Agency approval of the evaluations, a revised LoV may be established and incorporated in the operator's maintenance programme, together with any necessary actions to preclude WFD from occurring before the aircraft reaches the revised LoV.

The LoV and associated actions should be incorporated in the ALS. For an aircraft without an ALS, it may be appropriate for the DAH to create an ALS and to enter the LoV in the ALS, together with a clear identification of inspections and modifications required to allow safe operation up to that limit. Part 26.300 requires this for all large transport aeroplanes above 34 901 kg (75 000 lbs) MTOM.

In all cases, should instructions provided by the DAH in their ICA (e.g. maintenance manual revision) clearly indicate that the maintenance programme is not valid beyond a certain limit, this limit (i.e. LoV) and associated instructions must be adhered to in the operator's maintenance programme as approved by the competent authority under Part-M requirements, unless an EASA approved alternative programme is incorporated and approved.

11. SUPPLEMENTAL TYPE CERTIFICATES AND MODIFICATIONS

Any modification or supplemental type certificates (STC) affecting an aircraft's structure could have an effect on one or all aspects of ageing aircraft assessment as listed above. Such structural changes will need warrant the same consideration as the basic aircraft and the operator should seek support from the STC holder (who has primary responsibility for the design/certification of the STC), or an approved Design Organisation, where, for example an STC holder no longer exists. Appendix 3 provides further details.

STC holders are expected to review existing designs that may have implications for continued airworthiness in the context of ageing aircraft programmes and collaborate with operators and TCHs, where appropriate.

Part 26.330 for ageing aircraft specifies DT evaluations for specific groups of aircraft and modifications prior to their LoV. Part 26.350 for LoV extensions addresses existing modifications on all large transport aeroplanes that must be evaluated for WFD.

12. IMPLEMENTATION

Timescales for DAH development of certain large transport aeroplane programmes are provided in Part 26.300 to 26.350 and in Part 26.370 and for operator implementation of REGs there is further guidance to TCHs showing compliance with Part 26.320 in Appendix 3 to this AMC.

Where the type is not affected by these requirements the following guidance is provided.

In compliance with Part-M, operators must amend their current structural maintenance programmes to comply with and to account for new and/or modified applicable maintenance data promulgated by the DAH. New and/or revised maintenance data promulgated by the DAH becomes applicable when promulgated and when related to the type if they are not specifically intended to be approved by the Agency in the ageing aircraft rules. In cases where the DAH documentation is required to be approved by the Agency (ALS or documentation required by Part 26), the maintenance data only becomes formally applicable when the Agency has approved it. (Note: there are also ADs applicable to certain SSIDs, CPCPs, mod programmes and RAGs)

Appropriate implementation times for operators should be included in the TCH documentation and should be followed by the operator.

As a result of the industry/authority discussions leading to the definition of the programmes detailed in paragraphs 6 to 10 above, appropriate implementation times have emerged. The table below provides some guidelines. These programme implementation times are expressed as a fraction of the aircraft model's DSG. In the absence of other information prior to the implementation of these programmes the limit of validity of existing maintenance programmes should be considered to be as the DSG if it is known.

Programme	Affected structure*	Implementation
CPCP	All primary structure	1/2 DSG
SSIP	PSEs as defined in CS 25.571	1/2 DSG
SB Review	SBs that address a potentially unsafe structural condition	3/4 DSG
REGs and RAPS	Repairs to fatigue-critical structure (FCS)	3/4 DSG
WFD	PSEs susceptible to WFD	Not later than 1 DSG

* *Note:* The certification philosophy for safe-life items under CS 25.571 necessitates no further investigation under ageing aircraft programmes that would provide damage tolerance-based inspections. However, this does not exclude safe-life items such as landing gear from the CPCP and SB review or from reassessment of their safe-life if the aircraft usage or structural loading is known to have changed.

Programme implementation times in flight hours, flight or landing cycles, or calendar period, as appropriate, should may be established by the TC/STC holder based on the above table.

A period of up to one year may be allowed to incorporate the necessary actions into the operator's maintenance programme once they become available from the DAH. Grace periods for accomplishment of actions beyond threshold should address the level of risk and for large fleets the practicalities of scheduling maintenance activities. Typically, for maintenance actions beyond threshold, full implementation of these maintenance actions across the whole fleet should be accomplished within four years of the operator's programme being approved by the competent authority. For REGs and RAGs further advice for TCH development of timescales and operator implementation processes is provided in Appendix 3.

Where there is any doubt about applicability of the programme data or the timescales provided in TCH documentation, the Agency should be consulted by the operators and NAAs concerned.

Unless data is available on the dates of incorporation of repairs and modifications [STCs] they will need to be assumed as having the same age as the airframe.

APPENDIX 1
GUIDELINES FOR THE DEVELOPMENT
OF A SUPPLEMENTARY STRUCTURAL INSPECTION PROGRAMME

1. GENERAL

1.1. Purpose

This Appendix 1 gives interpretations, guidelines and acceptable means of compliance for the SSIP actions. An SSIP or DT-based ALS is required for all large transport aeroplanes addressed by Part 26.300. Other aircraft may benefit from an SSIP and some TCHs have already developed programmes for general aviation types that should also be implemented under Part-M requirements.

1.2. Background

Service experience has demonstrated that there is a need to have continuing updated knowledge concerning the structural integrity of aircraft, especially as they become older. Early fatigue requirements, such as 'fail safe' regulations, did not provide for timely inspection of an aircraft's critical structure to ensure that damaged or failed components could be dependably identified and then repaired or replaced before hazardous conditions developed.

In 1978 the damage tolerance concept was adopted for transport category aeroplanes in the USA as Amendment 25-45 to FAR 25.571. This amended rule required damage tolerance analyses as part of the type design of transport category aeroplanes for which application for type certification was received after the effective date of the amendment. In 1980 the requirement for damage tolerance analyses was also included in JAR 25.571 Change 7.

One prerequisite for the successful application of the damage tolerance approach for managing fatigue is that crack growth and residual strength can be anticipated with sufficient precision to allow inspections to be established that will detect cracking before it reaches a size that will degrade the strength below a specified level. When damage is discovered, airworthiness is ensured by repair or revised maintenance action. Evidence to date suggests that when all critical structure is included, fatigue and damage tolerance-based inspections and procedures (including modification and replacement when necessary) provide the best approach to address aircraft fatigue.

Pre-FAR Part 25 Amendment 25-45 (JAR 25 Change 7) aeroplanes were built to varying standards that embodied fatigue and fail-safe requirements. These aeroplanes, as certified, had no specific mandated requirements to perform inspections for fatigue. Following the amendment of FAR 25 to embody damage tolerance requirements, the FAA published Advisory Circular 91-56. That AC was applicable to pre-Amendment 25-45 aeroplanes with a maximum gross weight greater than 75 000 lbs (34 019 kg). According to the AC, the TCH, in conjunction with operators, was expected to initiate development of an SSIP for each aeroplane model.

AC 91-56A provided guidance material for the development of such programmes based on damage tolerance principles. Many TCHs of large aeroplanes developed SSIPs for their pre-Amendment 25-45 aeroplanes. The documents containing the SSIP are designated Supplemental Structural Inspection Documents (SSID) or Supplemental Inspection Documents (SID).

The competent authorities have in the past issued a series of ADs requiring compliance with these SSIPs. Generally these ADs require the operators to incorporate the SSIPs into their maintenance programmes. Under Part-M requirements it is expected that an operator will automatically incorporate the SSID into their maintenance programme once it is approved by the Agency, unless already mandated by AD.

For post-Amendment 25-45 aeroplanes, it was required that inspections or other procedures should be developed based on the damage tolerance evaluations required by FAR 25.571, and included in the maintenance data. In Amendment 25-54 to FAR 25 and change 7 to JAR-25 it was required to include these inspections and procedures in the ~~Airworthiness Limitations Section ALS~~ of the ~~Instructions for Continued Airworthiness ICA~~ required by 25.1529. At the same amendment, 25.1529 was changed to require applicants for type certificates to prepare ~~Instructions for Continued Airworthiness ICA~~ in accordance with Appendix H to of FAR/JAR-25. Appendix H requires that the ~~Instructions for Continued Airworthiness ICA~~ must contain a section titled Airworthiness Limitations that is segregated and clearly distinguishable from the rest of the document. This section shall contain the information concerning inspections and other procedures as required by FAR/JAR/CS 25.571.

The content of the ~~Airworthiness Limitations Section ALS~~ of the ~~Instructions for Continued Airworthiness ICA~~ is designated by some TCHs as Airworthiness Limitations Instructions (ALI). Other TCHs have decided to designate the same items as Airworthiness Limitations Items (ALI).

~~Compliance with FAR/JAR 25.571 at Amendment 25-45 and Change 7 respectively, or later amendments, results in requirements to periodically inspect aeroplanes for potential fatigue damage in areas where it is most likely to occur.~~

Again, Part-M requires the ALS to be incorporated into the operator's maintenance programme.

2. SUPPLEMENTAL STRUCTURAL INSPECTION PROGRAMME (SSIP)

Increased utilisation, longer operational lives, and the high safety demands imposed on the current fleet of transport aeroplanes indicate the need for a programme to ensure a high level of structural integrity for all aeroplanes in the transport fleet.

This AMC is intended to provide guidance to TCHs and other DAHs to develop or review existing inspection programmes for effectiveness. SSIPs are based on a thorough technical review of the damage tolerance characteristics of the aircraft structure using the latest techniques and changes in operational usage. They lead to revised or new inspection requirements primarily for structural cracking and replacement or modification of structure where inspection is not practical.

Whether the aircraft was originally certified to be damage-tolerant or not, the TCH should review operational usage on a regular basis, say every five years, and ensure that it remains in accordance with the assumptions made at certification or when the SSIP was first developed. Factors such as payload, fuel at take-off and landing, flight profile, etc., should be addressed. For large transport aeroplanes the requirement Part 26.300 stipulates that a CAW process must be in place to achieve this.

Large transport aeroplanes that were certified according to FAR 25.571 Amendment 25-45/54 or JAR 25 Change 7 or later are damage-tolerant. The fatigue requirements are part of the MRB Report, as required by ATA MSG-3. However, for pre-ATA MSG-3 Rev 2 aeroplanes there are no requirements for regular MRB Report review and for post-ATA MSG-3 Rev 2 aeroplanes there is only a requirement for regular MRB Report review in order to assess if the CPCP is effective. Concerning ageing aircraft activities, it is

important to regularly review the part of the MRB Report containing the structural inspections resulting from the fatigue and damage tolerance analysis for effectiveness.

2.1. Pre-Amendment 25-45 aeroplanes

The TCH is expected to initiate development of an SSIP for each aeroplane model. Such a programme must be implemented before analysis, test and/or service experience indicate that a significant increase in inspection and or modification is necessary to maintain structural integrity of the aeroplane. This should ensure that an acceptable programme is available to the operators when needed. The programme should include procedures for obtaining service information, and assessment of service information, available test data, and new analysis and test data.

An SSID should be developed in accordance with Paragraph 3 of this Appendix 1. The recommended SSIP, along with the criteria used and the basis for the criteria, should be submitted by the TCH to the Agency for approval. The SSIP should be adequately defined in the SSID and presented in a manner that is effective. The SSID should include the type of damage being considered, and likely sites; inspection access, threshold, interval method and procedures; applicable modification status and/or life limitation; and types of operation for which the SSID is valid.

The review of the SSID by the Agency will include both engineering and maintenance aspects of the proposal. In the event an acceptable SSID cannot be obtained on a timely basis the competent authority may impose service life, operational, or inspection limitations to assure structural integrity.

The TCH should check the SSID periodically against current service experience. This should include an evaluation of current methods and findings. Any unexpected defect occurring should be assessed as part of the continuing assessment of structural integrity to determine a need for revision to the document.

2.2. Post-Amendment 25-45 aeroplanes

Aeroplanes certificated to FAR 25.571 Amendment 25-45, JAR 25.571 Change 7 and CS-25 or later amendments are damage-tolerant. The airworthiness limitations including the inspections and procedures established in accordance with FAR/JAR/CS 25.571 shall be included in the ~~Instructions for Continuing Airworthiness ICA~~, ref. FAR/JAR/CS 25.1529. Further guidance for the actual contents is incorporated in FAR/JAR/CS-25 Appendix H.

To maintain the structural integrity of these aeroplanes it is necessary to follow up the effectiveness of these inspections and procedures. The DAH should therefore check this information periodically against current service experience. Any unexpected defect occurring should be assessed as part of the continuing assessment of structural integrity to determine a need for revision to this information. The revised data should be developed in accordance with the same procedures as at type certification giving consideration to any additional test or service data available and changes to aeroplanes operating patterns.

3. GUIDELINES FOR DEVELOPMENT OF THE SUPPLEMENTAL STRUCTURAL INSPECTION DOCUMENT

This paragraph is based directly on Appendix 1 to FAA AC 91-56AB which applies to transport category aeroplanes that were certificated prior to Amendment 25-45 of FAR 25 or equivalent requirement.

3.1. General

Amendment 25-45 to § 25.571 introduced wording which emphasises damage-tolerant design. However, the structure to be evaluated, the type of damage considered (fatigue, corrosion, service, and production damage), and the inspection and/or modification criteria should, to the extent practicable, be in accordance with the damage tolerance principles of the current § 25.571 standards. An acceptable means of compliance can be found in AC 25.571-1C ('Damage-Tolerance and Fatigue Evaluation of Structure', dated April 29, 1998) or the latest revision.

It is essential to identify the structural parts and components that contribute significantly to carrying flight, ground, pressure, or control loads, and whose failure could affect the structural integrity necessary for the continued safe operation of the aeroplane. The damage tolerance of these parts and components must be established or confirmed. Following the guidance material of AMC 25.571, it is essential that inspections provided in the SSIP or ALS are practical and effective in maintaining airworthiness. Where this is not the case modifications or replacements must be considered.

Analyses made in respect of the continuing assessment of structural integrity should be based on supporting evidence, including test and service data. This supporting evidence should include consideration of the operating loading spectra, structural loading distributions, and material behaviour. Appropriate allowance should be made for the scatter in life to crack initiation and rate of crack propagation in establishing the inspection threshold, inspection frequency, and, where appropriate, retirement life. Alternatively, an inspection threshold may be based solely on a statistical assessment of fleet experience, if it can be shown that equal confidence can be placed in such an approach.

An effective method of evaluating the structural condition of older aeroplanes is selective inspection with intensive use of non-destructive techniques, and the inspection of individual aeroplanes, involving partial or complete dismantling ('teardown') of available structure.

The effect of repairs and modifications approved by the TCH should be considered. In addition, it may be necessary to consider the effect of repairs and operator-approved or other DAH modifications on individual aircraft. The operator has the responsibility for ensuring notification and consideration of any such aspects in conjunction with the DAH. Guidance on the Agency's requirements for DT of repairs and modifications is found in Appendix 3 to this AMC and further guidance for WFD evaluation of repairs and modifications is provided in Section 7 of Appendix 2.

3.2. Damage-tolerant structures

The damage tolerance assessment of the aircraft structure should be based on the best information available. The assessment should include a review of analysis, test data, operational experience, and any special inspections related to the type design.

A determination should then be made of the site or sites within each structural part or component considered likely to crack, and the time or number of flights at which this might occur.

The growth characteristics of damage and interactive effects on adjacent parts in promoting more rapid or extensive damage should be determined. This determination should be based on study of those sites that may be subject to the possibility of crack initiation due to fatigue, corrosion, stress corrosion, disbonding, accidental damage, or manufacturing defects in those areas shown to be vulnerable by service experience or design judgement. The damage tolerance certification specification of CS 25.571 requires

not only fatigue damage to be addressed but also accidental and environmental damage. Some types of accidental damage (e.g. scribe marks) cannot be easily addressed by the MSG process and require specific inspections based on fatigue and damage tolerance analysis and tests. Furthermore, some applicants may choose to address other types of accidental damage and environmental damage in the SSID or ALS by modelling the damage as a crack and performing a fatigue and damage tolerance analysis. The resulting inspection programme may be tailored to look for the initial type of damage or the resulting fatigue cracking scenario, or both.

The minimum size of damage that is practical to detect and the proposed method of inspection should be determined. This determination should take into account the number of flights required for the crack to grow from detectable to the allowable limit, such that the structure has a residual strength corresponding to the conditions stated under CS 25.571.

Note: In determining the proposed method of inspection, consideration should be given to visual inspection, non-destructive testing, and analysis of data from built-in load and defect monitoring devices.

The continuing assessment of structural integrity may involve more extensive damage than might have been considered in the original fail-safe evaluation of the aircraft, such as:

- (a) a number of small adjacent cracks, each of which may be less than the typically detectable length, developing suddenly into a long crack;
- (b) failures or partial failures in other locations following an initial failure due to redistribution of loading causing a more rapid spread of fatigue; and
- (c) concurrent failure or partial failure of multiple load path elements (e.g. lugs, planks, or crack arrest features) working at similar stress levels.

3.3. Information to be included in the assessment

The continuing assessment of structural integrity for the particular aircraft type should be based on the principles outlined in paragraph 3.2 of this Appendix. The following information should be included in the assessment and kept by the TCH in a form acceptable to the Agency:

- (a) the current operational statistics of the fleet in terms of hours or flights;
- (b) the typical operational mission or missions assumed in the assessment;
- (c) the structural loading conditions from the chosen missions; and
- (d) supporting test evidence and relevant service experience.

In addition to the information specified in paragraph 3.3 above, the following should be included for each critical part or component:

- (a) the basis used for evaluating the damage tolerance characteristics of the part or component;
- (b) the site or sites within the part or component where damage could affect the structural integrity of the aircraft;
- (c) the recommended inspection methods for the area;
- (d) for damage-tolerant structures, the maximum damage size at which the residual strength capability can be demonstrated and the critical design loading case for the latter; and

- (e) for damage-tolerant structures, at each damage site the inspection threshold and the damage growth interval between detectable and critical, including any likely interaction effect from other damage sites.

Note: Where re-evaluation of fail-safety or damage tolerance of certain parts or components indicates that these qualities cannot be achieved, or can only be demonstrated using an inspection procedure whose practicability or reliability may be in doubt, replacement or modification action may need to be defined.

3.4. Inspection programme

The purpose of a continuing airworthiness assessment in its most basic terms is to adjust the current maintenance inspection programme, as required, to assure continued safety of the aircraft type.

In accordance with paragraphs 1 and 2 of this Appendix 1, an allowable limit of the size of damage should be determined for each site such that the structure has a residual strength for the load conditions specified in CS 25.571. The size of damage that is practical to detect by the proposed method of inspection should be determined, along with the number of flights required for the crack to grow from detectable to the allowable limit.

The recommended inspection programme should be determined from the data described in paragraph 3.3 above, giving due consideration to the following:

- (a) fleet experience, including all of the scheduled maintenance checks;
- (b) confidence in the proposed inspection technique; and
- (c) the joint probability of reaching the load levels described above and the final size of damage in those instances where probabilistic methods can be used with acceptable confidence.

Inspection thresholds for supplemental inspections should be established. These inspections would be supplemental to the normal inspections, including the detailed internal inspections.

- (a) For structure with reported cracking, the threshold for inspection should be determined by analysis of the service data and available test data for each individual case.
- (b) For structure with no reported cracking, it may be acceptable, provided sufficient fleet experience is available, to determine the inspection threshold on the basis of analysis of existing fleet data alone. This threshold should be set such as to include the inspection of a sufficient number of high-time aircraft to develop added confidence in the integrity of the structure (see paragraph 1 of this Appendix).

3.5. The Supplemental Structural Inspection Document (SSID)

The SSID should contain the recommendations for the inspection procedures and replacement or modification of parts or components necessary for the continued safe operation of the aircraft up to the LoV. Where an LoV is not provided as a result of needing to meet a specific requirement for an LoV, the applicant must consider all likely fatigue scenarios up to an operational life that is either conservatively set based on experience or rational assumptions of usage or otherwise limited in the ALS. The document should be prefaced by the following information:

- (a) identification of the variants of the basic aircraft type to which the document relates;
- (b) reference to documents giving any existing inspections or modifications of parts or components;
- (c) the types of operations for which the inspection programme is considered valid;
- (d) a list of Service Bulletins (or other service information publication) revised as a result of the structural reassessment undertaken to develop the SSID, including a statement that the operator must account for these service bulletins;
- (e) the type of damage which is being considered (i.e. fatigue, corrosion and/or accidental damage);
- (f) guidance to the operator on which inspection findings should be reported to the type certificate holder.

The document should contain at least the following information for each critical part or component (PSE and FCS):

- (a) a description of the part or component and any relevant adjacent structure, including means of access to the part;
- (b) relevant service experience;
- (c) likely site(s) of damage;
- (d) inspection method and procedure, and alternatives;
- (e) minimum size of damage considered detectable by the method(s) of inspection;
- (f) Service Bulletins (or other service information publication) revised or issued as a result of in-service findings resulting from implementation of the SSID (added as revision to the initial SID);
- (g) initial inspection threshold;
- (h) repeat inspection interval;
- (i) reference to any optional modification or replacement of part or component as terminating action to inspection;
- (j) reference to the mandatory modification or replacement of the part or component at given life, if fail-safety by inspection is impractical; and
- (k) information related to any variations found necessary to 'safe lives' already declared.

The SSID should be compared from time to time against current service experience. Any unexpected defect occurring should be assessed as part of the continuing assessment of structural integrity to determine the need for revision of the SSID. Future structural Service Bulletins should state their effect on the SSID.

APPENDIX 2

GUIDELINES FOR THE DEVELOPMENT OF A PROGRAMME TO PRECLUDE THE OCCURRENCE OF WFD

1. INTRODUCTION

The terminology and methodology in this Appendix are based upon material developed by the AAWG.

2. DEFINITIONS

- **Extended Service Goal (ESG)** is an adjustment to the design service goal established by service experience, analysis, and/or test during which the principal structure will be reasonably free from significant cracking including widespread fatigue damage.
- **Inspection Start Point (ISP)** is the point in time when special inspections of the fleet are initiated due to a specific probability of having an MSD/MED condition.
- **Large Damage Capability (LDC)** is the ability of the structure to sustain damage visually detectable under an operator's normal maintenance that is caused by accidental damage, fatigue damage, and environmental degradation, and still maintain limit load capability with MSD to the extent expected at SMP.
- **Monitoring Period** is the period of time when special inspections of the fleet are initiated due to an increased risk of MSD/MED (ISP) and ending when the SMP is reached.
- **Scatter Factor** is a life reduction factor used in the interpretation of fatigue analysis and fatigue test results.
- **Structural Modification Point (SMP)** is a point reduced from the WFD average behaviour (i.e. lower bound), so that operation up to that point provides equivalent protection to that of a two-lifetime fatigue test. No aircraft should be operated beyond the SMP without modification or part replacement.
- **Test-to-Structure Factor** is a series of factors used to adjust test results to full-scale structure. These factors could include, but are not limited to, differences in:
 - stress spectrum,
 - boundary conditions,
 - specimen configuration,
 - material differences,
 - geometric considerations, and
 - environmental effects.
- **Teardown inspections** can be destructive and can be performed on fatigue tested structural components or those that have been removed from service. Alternatively they involve local teardown (non-destructive) disassembly and subsequent refurbishment of specific areas of high-time aircraft in service. The liberated sections of structure are then inspected using visual and non-destructive inspection technology, to characterise the extent of damage within the structure with regard to corrosion, fatigue, and accidental damage.

- **WFD** (average behaviour) is the point in time when 50 % of the fleet is expected to reach WFD for a particular detail.

3. GENERAL

The likelihood of the occurrence of fatigue damage in an aircraft's structure increases with aircraft usage. The design process generally establishes a design service goal (DSG) in terms of flight cycles/hours for the airframe. It is expected that any cracking that occurs on an aircraft operated up to the DSG will occur in isolation (i.e. local cracking), originating from a single source, such as a random manufacturing flaw (e.g. a mis-drilled fastener hole) or a localised design detail. It is considered unlikely that cracks from manufacturing flaws or localised design issues will interact strongly as they grow.

With extended usage, uniformly loaded structure may develop cracks in adjacent fastener holes, or in adjacent similar structural details. These cracks may or may not interact, and they can have an adverse effect on the LDC of the structure before the cracks become detectable. The development of cracks at multiple locations (both MSD and MED) may also result in strong interactions that can affect subsequent crack growth; in which case, the predictions for local cracking would no longer apply. An example of this situation may occur at any skin joint where load transfer occurs. Simultaneous cracking at many fasteners along a common rivet line may reduce the residual strength of the joint below the required levels before the cracks are detectable under the routine maintenance programme established at the time of certification.

~~Because of the small probability of occurrence of MSD/MED in aircraft operation up to its DSG, maintenance programmes developed for initial certification have generally considered only local fatigue cracking. Therefore, as the aircraft reaches its DSG, it is necessary to take appropriate action in the ageing fleets to preclude WFD so that continued safe operation of the aircraft is not jeopardised.~~

For new type designs, certified to CS-25 Amdt X, AMC 25.571 provides guidance on how to establish an LoV. For existing types the guidance of this AMC applies. The DAH and/or the operator(s) should conduct structural evaluations to determine where and when MSD/MED may occur. Based on these evaluations the DAH and in some cases the operator(s) would provide additional maintenance instructions for the structure, as appropriate. The maintenance instructions include, but are not limited to, inspections, structural modifications, and limits of validity of the new maintenance instructions. In most cases, a combination of inspections and/or modifications/replacements is deemed necessary to achieve the required safety level. Other cases will require modification or replacement if inspections are not viable.

There is a distinct possibility that there could be a simultaneous occurrence of MSD and MED in a given structural area. This situation is possible on some details that were equally stressed. If this is possible, then this scenario should be considered in developing appropriate service actions for structural areas.

4. STRUCTURAL EVALUATION FOR WFD

4.1. General

The evaluation has three objectives:

- (a) Identify primary structure and in particular fatigue-critical structure that may be susceptible to MSD/MED; see paragraph 4.2;
- (b) Predict when it is likely to occur; see paragraph 4.3; and
- (c) Establish additional maintenance actions, as necessary, to ensure continued safe operation of the aircraft; see paragraph 4.4.

4.2. Structure susceptible to MSD/MED

Susceptible structure is defined as that which has the potential to develop MSD/MED. Such structure typically has the characteristics of multiple similar details operating at similar stresses where structural capability could be affected by interaction of multiple cracking at a number of similar details. The following list provides examples of known types of structure susceptible to MSD/MED (the list is not exhaustive):

STRUCTURAL AREA	SEE FIGURE
Longitudinal skin joints, frames, and tear straps (MSD/MED)	A2-1
Circumferential joints and stringers (MSD/MED)	A2-2
Lap joints with milled, chem-milled or bonded radius (MSD)	A2-3
Fuselage frames (MED)	A2-4
Stringer-to-frame attachments (MED)	A2-5
Shear clip end fasteners on shear tied fuselage frames (MSD/MED)	A2-6
Aft pressure dome outer ring and dome web splices (MSD/MED)	A2-7
Skin splice at aft pressure bulkhead (MSD)	A2-8
Abrupt changes in web or skin thickness — Pressurised or un-pressurised structure (MSD/MED)	A2-9
Window surround structure (MSD, MED)	A2-10
Overwing fuselage attachments (MED)	A2-11
Latches and hinges of non-plug doors (MSD/MED)	A2-12
Skin at runout of large doubler (MSD) — Fuselage, wing or empennage	A2-13
Wing or empennage chordwise splices (MSD/MED)	A2-14
Rib-to-skin attachments (MSD/MED)	A2-15
Typical wing and empennage construction (MSD/MED)	A2-16

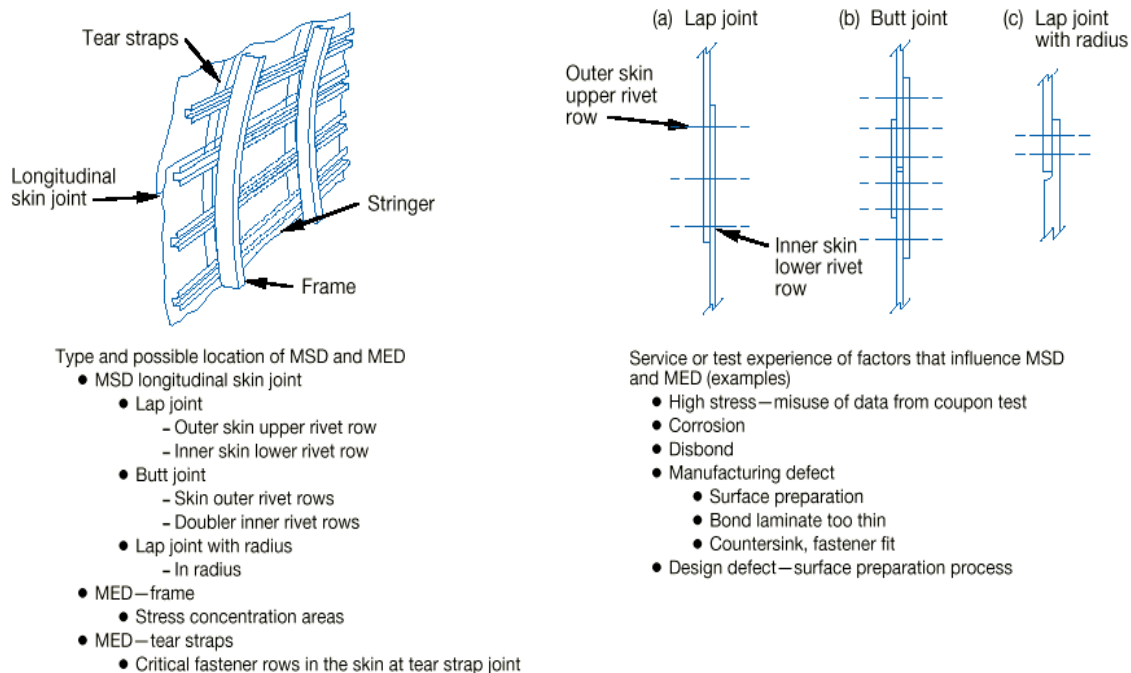
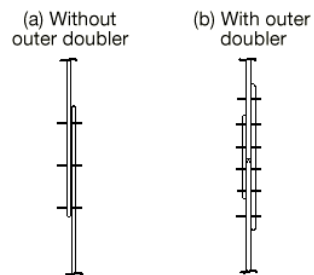
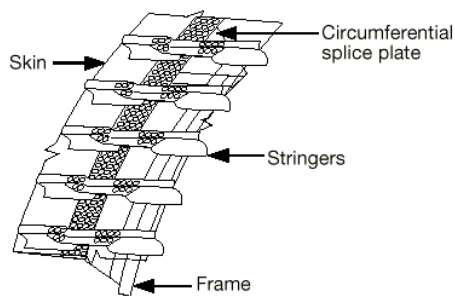

Figure A2-1: Longitudinal skin joints, frames, and tear straps (MSD/MED)



Type and possible location of MSD/MED

- MSD—circumferential joint
 - Without outer doubler
 - Splice plate—between and/or at the inner two rivet rows
 - Skin—forward and aft rivet row of splice plate
 - Skin—at first fastener of stringer coupling
 - With outer doubler
 - Skin—outer rivet rows
 - Splice plate/outer doubler—inner rivet rows
- MED—stringer/stringer couplings
 - Stringer—at first fastener of stringer coupling
 - Stringer coupling—in splice plate area

Service or test experience of factors that influence MSD and/or MED (examples)

- High secondary bending
- High stress level in splice plate and joining stringers (misuse of data from coupon test)
- Poor design (wrong material)
- Underdesign (over-estimation of interference fit fasteners)

Figure A2-2: Circumferential joints and stringers (MSD/MED)

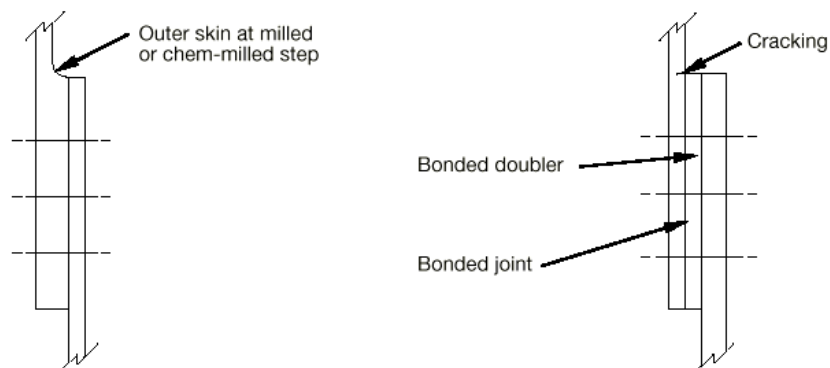

Type and possible location of MSD and MED

- MSD—abrupt cross section change
- Milled radius
- Chem-milled radius
- Bonded doubler runout

Service or test experience of factors that influence MSD and MED (examples)

- High bending stresses due to eccentricity

Figure A2-3: Lap joints with milled, chem-milled or bonded radius (MSD)

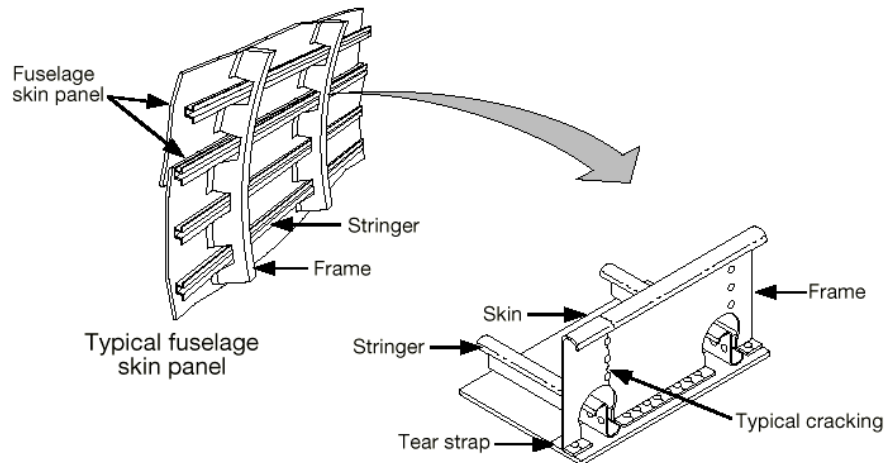

Type and possible location of MSD/MED

- MED—the cracking of frames at stringer cutouts at successive longitudinal locations in the fuselage. The primary concern is for those areas where noncircular frames exist in the fuselage structure. Fractures in those areas would result in panel instability.

Service or test experience of factors that influence MSD and/or MED (examples)

- High bending—noncircular frames
- Local stress concentrations
 - Cutouts
 - Shear attachments

Figure A2-4: Fuselage frames (MED)

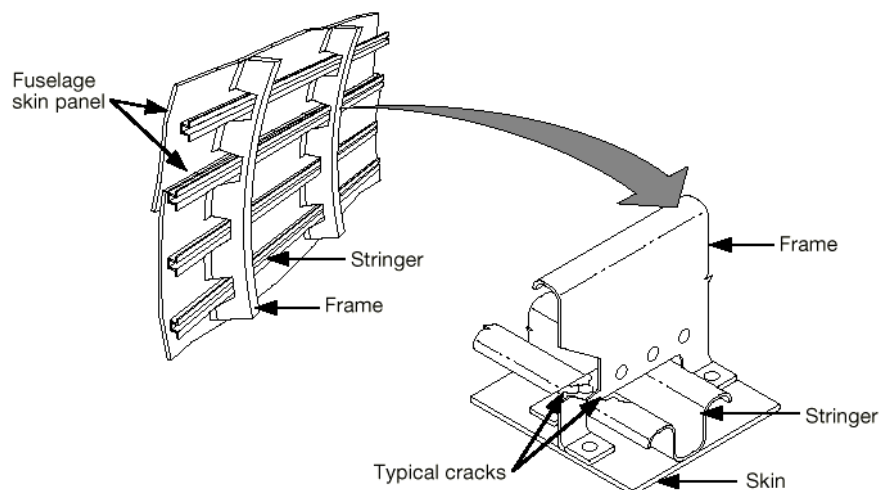

Type and possible location of MED

- MED—any combination of fracture of frames, clips, or stringers, including the attachments, resulting in the loss of the shear tie between the frame and stringer. This condition may occur at either circumferential or longitudinal locations at fuselage frame/stringer intersection.

Service or test experience of factors that influence MSD and/or MED (examples)

- Poor load path connection

Figure A2-5: Stringer-to-frame attachments (MED)

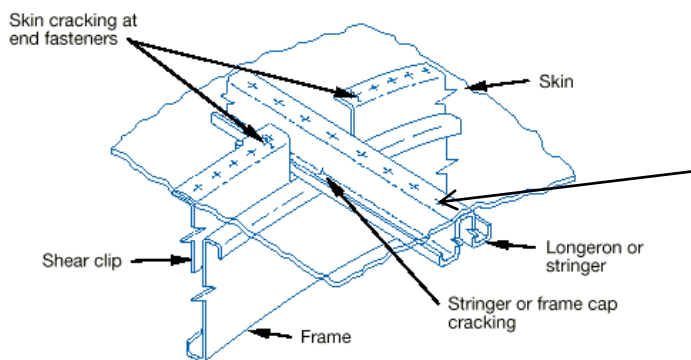

Type and possible location of MSD and MED

- MSD—skin at end fastener of shear clip
- MED—cracking in stringer or longeron at frame attachment
- MED—cracking in frame at stringer or longeron attachment

Service or test experience of factors that influence MSD and MED (examples)

- Preload
- Localized bending due to pressure
- Discontinuous load path

Figure A2-6: Shear clip end fasteners on shear tied fuselage frame (MSD/MED)

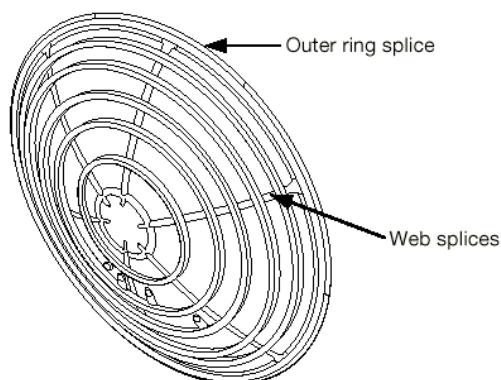

Typical outer ring splices

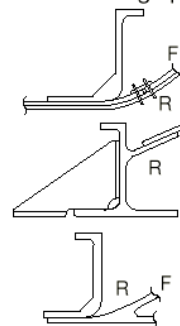

Legend:
 F fastener
 R radius

Type and possible location of MSD/MED

- MSD/MED—outer ring splice
 - Attachment profiles—at fastener rows and/or in radius area
- MED—web splices
 - Bulkhead skin and/or splice plates—at critical fastener rows

Service or test experience of factors that influence MSD and/or MED (examples)

- Corrosion
- High stresses—combined tension and compression
- High induced bending in radius
- Inadequate finish in radius—surface roughness

Figure A2-7: Aft pressure dome outer ring and dome web splices (MSD/MED)

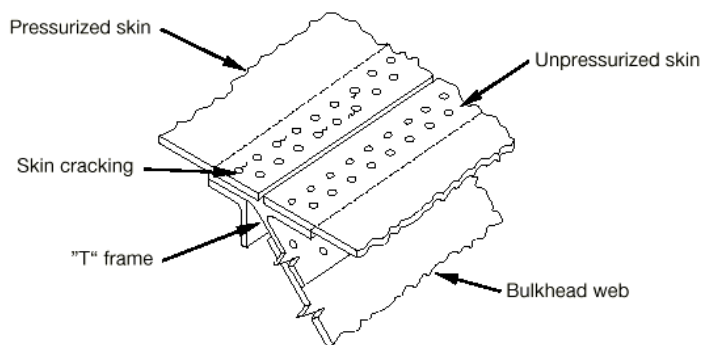

Type and possible location of MSD and MED

- MSD—skin at end fastener holes

Service or test experience of factors that influence MSD and MED (examples)

- Shell discontinuous induced bending stresses
- High load transfer at fastener

Figure A2-8: Skin splice at aft pressure bulkhead (MSD)

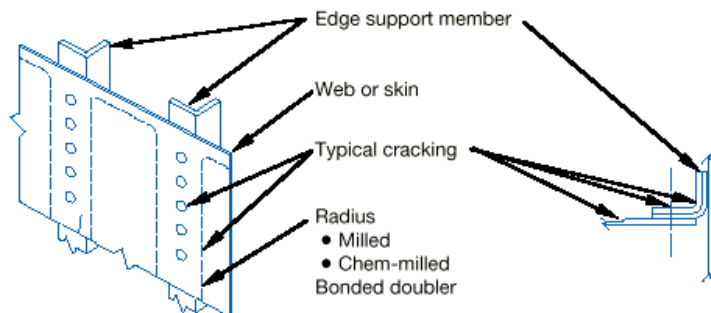

Type and possible location of MSD and MED

- Abrupt change in stiffness*
- Milled radius
 - Chem-milled radius
 - Bonded doubler
 - Fastener row at edge support members
- Edge member support structure
- Edge member - in radius areas

Service or test experience of factors that influence MSD and MED

- Pressure structure
- High bending stresses at edge support due to pressure
- Non-pressure structure
- Structural deflections cause high stresses at edge supports

Figure A2-9: Abrupt changes in web or skin thickness — Pressurised or unpressurised structure (MSD/MED)

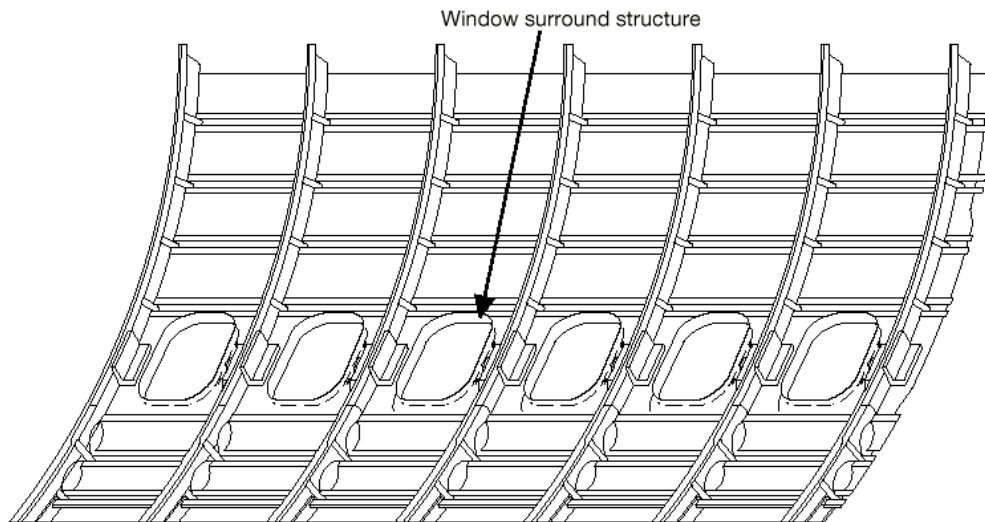

Type and possible location of MSD/MED

- MSD—skin at attachment to window surround structure
- MED—repeated details in reinforcement of window cutouts or in window corners

Service or test experience of factors that influence MSD and/or MED (examples)

- High load transfer

Figure A2-10: Window surround structure (MSD/MED)

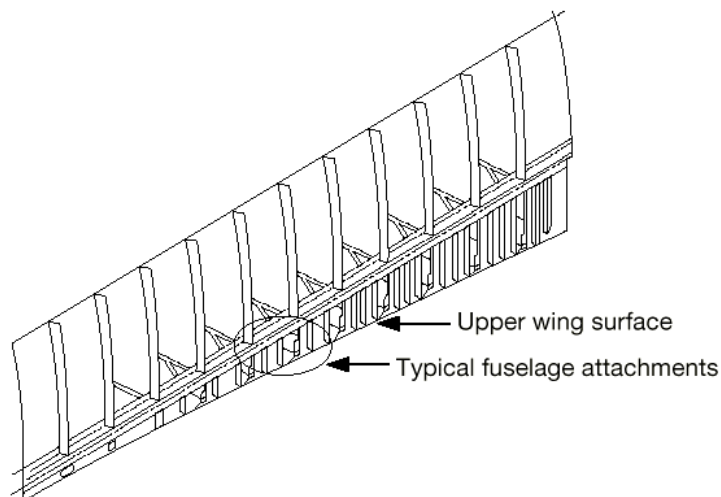

Type and possible location of MSD/MED

- MED—repeated details in overwing fuselage attachments

Service or test experience of factors that influence MSD and/or MED (examples)

- Manufacturing defect—prestress
- Induced deflections

Figure A2-11: Overwing fuselage attachments (MED)

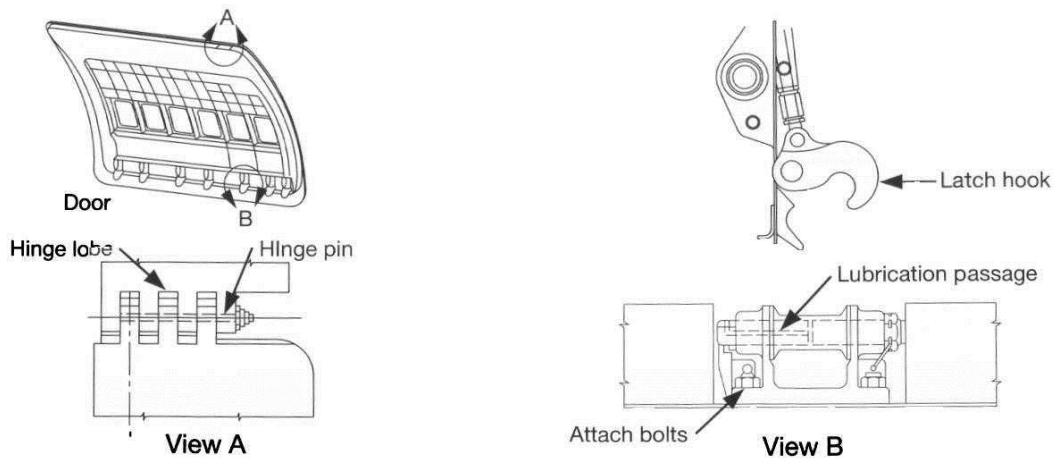

Type and possible location of MSD/MED

- MSD—piano hinge
 - At hinge fastener attachment row
 - In fillet radius
 - Emanating from hole in lobes
- MED—latches
 - In multiple latch hooks
 - At lube channel of latch spool
 - At spool bracket attach bolts (also corrosion)

Service or test experience of factors that influence MSD and/or MED (examples)

- Bending stresses due to fuselage elongation
- High local stress
- Fretting

Figure A2-12: Latches and hinges of non-plug doors (MSD/MED)

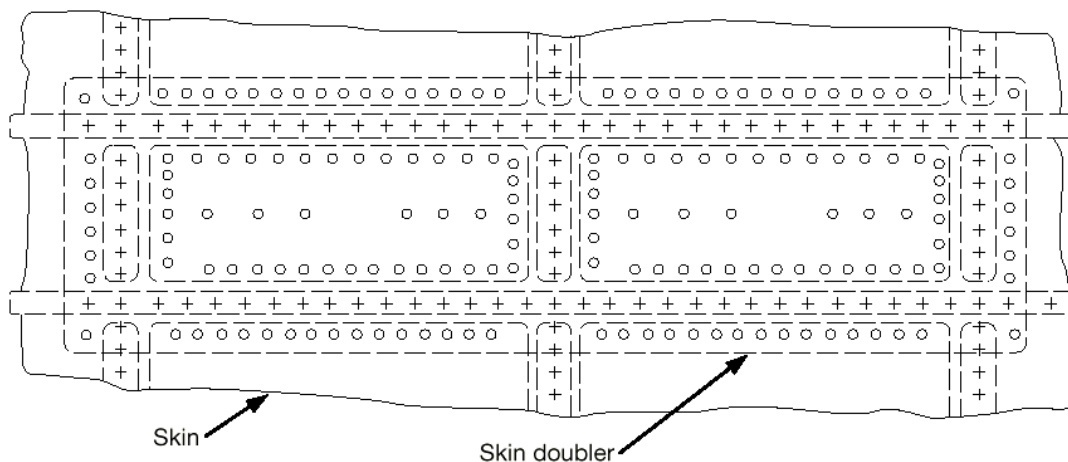

Type and possible location of MSD/MED

- MSD—cracks initiated at multiple critical fastener holes in skin at runout of doubler

Service or test experience of factors that influence MSD and/or MED (examples)

- High load transfer—high local stress

Figure A2-13: Skin at runout of large doubler (MSD) — Fuselage, wing or empennage

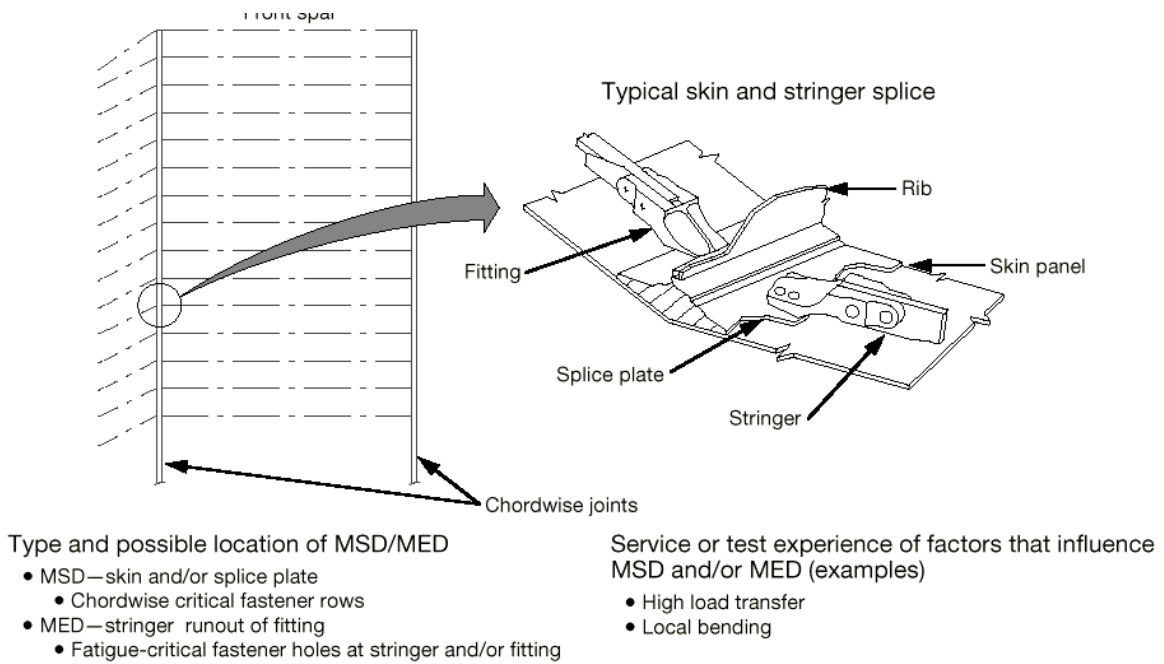

Figure A2-14: Wing or empennage chordwise splices (MSD/MED)

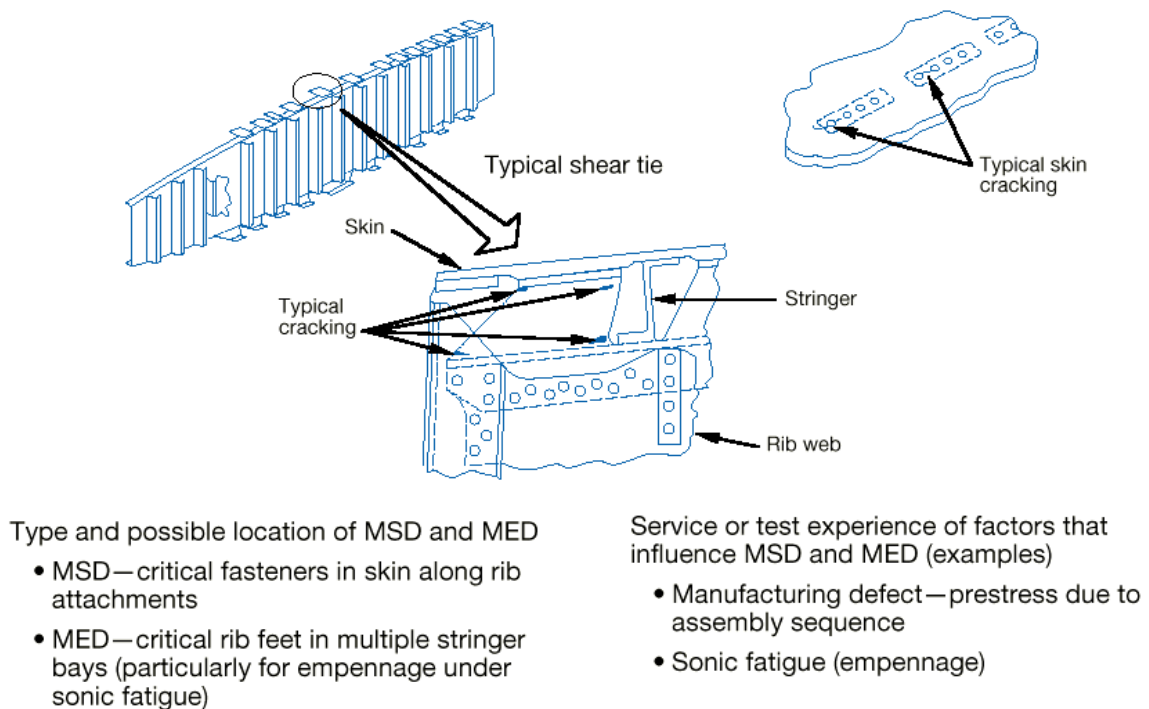

Figure A2-15: Rib-to-skin attachments (MSD/MED)

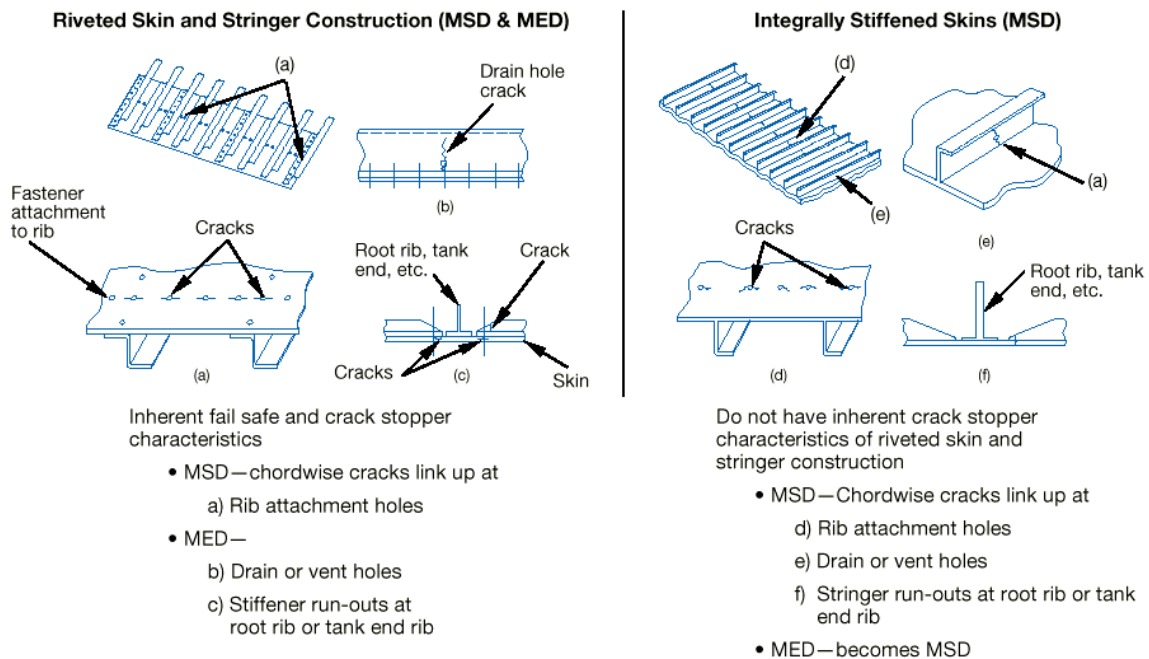

Figure A2-16: Typical wing and empennage construction (MSD/MED)

4.3. WFD evaluation

Part 26.300 requires that an LoV is established according to specified timescales for large transport aeroplanes with MTOM above 34 901 kg (75 000 lbs). For other types it is recommended that by the time the highest-time aircraft of a particular model reaches its DSG, the evaluation for each area susceptible to the development of WFD should be completed. A typical evaluation process is shown in Figure A2-19 below. This evaluation will establish the necessary elements to determine a maintenance programme to preclude WFD in that particular model's aircraft fleet. These elements are developed for each susceptible area and include:

4.3.1. Identification of structure potentially susceptible to WFD

Unless already fully addressed in the existing fatigue and damage tolerance evaluation the TCH should identify each part of the aircraft's structure that is potentially susceptible to WFD for further evaluation. A justification should be given that supports selection or rejection of each area of the aircraft structure. DAHs for modified or repaired structure should evaluate their structure and its effect on existing structure.

Typical examples of structure susceptible to WFD are included in paragraph 4.2 of this Appendix.

4.3.2. Predicting when WFD will occur

(a) Characterisation of events leading to WFD. The fatigue process that leads to WFD is shown in Figure A2-17. This figure is applicable to both damage that occurs in multiple sites (multiple site damage) and damage that occurs in similar structure at more than one location (multiple element damage). For any susceptible structural area, it is not a question of whether WFD will occur, but when it will occur. In Figure A2-17, the 'when' is illustrated by the line titled 'WFD (average behaviour)', which is the point when 50 per cent of the aeroplanes in a fleet would have experienced WFD in the considered area (note that the probability density function for flight cycles or flight hours to WFD has been depicted for reference). The WFD process includes this phase of crack initiation and a crack growth phase. During the crack initiation phase, which generally spans a long

period of time, there is little or no change in the basic strength capability of the structure. The actual residual strength curve depicted in Figure A2-17 is flat, and equal to the strength of the structure in its pristine state. However, at some time after the first small cracks start to grow, residual strength begins to degrade. Crack growth continues until the capability of the structure degrades to the point of the minimum strength required by 25.571(b). In this context, the line in Figure A2-17 called WFD *(average behaviour)* represents a point when 50 per cent of the aeroplanes in a fleet fall below the minimum strength requirements of 25.571(b).

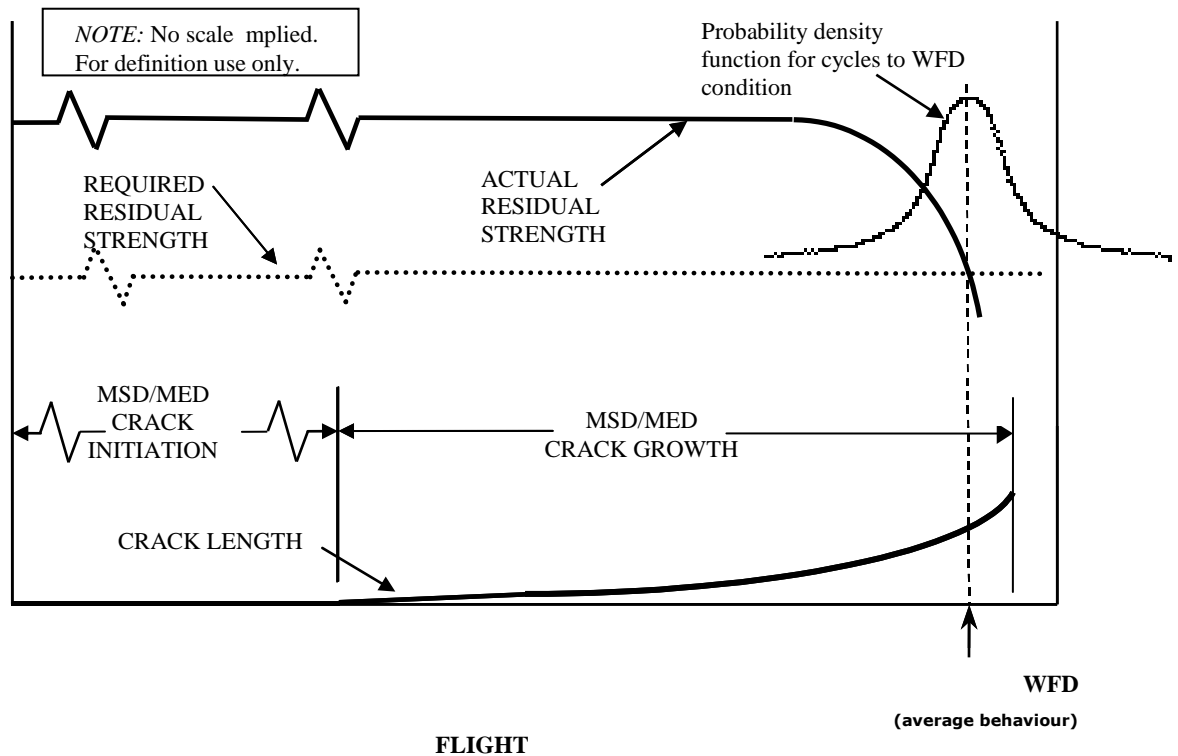

Figure A2-17: Effect on residual strength of developing WFD

(b) Determination of WFD *(average behaviour)* in the fleet

The time in terms of flight cycles/hours defining the WFD *(average behaviour)* in the fleet should be established for each susceptible structural area. The data to be assessed in determining the WFD *(average behaviour)* includes:

- a complete review of the service history of the susceptible areas, to identify any occurrences of fatigue cracking and the continuing validity of loads and mission profiles,
- evaluation of the operational statistics of the fleet in terms of flight hours and landings,
- significant production variants (material, design, assembly method, and any other change that might affect the fatigue performance of the detail),
- fatigue test evidence including relevant full-scale and component fatigue and damage tolerance test data (see subparagraph 4.3.9 and Annex 1 for more details),
- teardown inspections, and
- any fractographic analysis available.

The evaluation of the test results for the reliable prediction of the time to when WFD might occur in each susceptible area should include appropriate test-to-structure factors. If full-scale fatigue test evidence is used, Figure A2-1820 below relates how that data

might be utilised in determining WFD (average behaviour). Evaluation may be analytically determined, supported by test and, where available, service evidence.

Regardless of whether the assessment of WFD (average behaviour) is based on in-service data, full-scale fatigue test evidence, analyses, or a combination of any of these, the following should be considered:

4.3.3. Initial crack/damage scenario

This is an estimate of the size and extent of multiple cracking expected at MSD/MED initiation. This prediction requires empirical data or an assumption of the crack/damage locations and sequence plus a fatigue evaluation to determine the time to MSD/MED initiation. Alternatively, analysis can be based on either:

- the distribution of equivalent initial flaws, as determined from the analytical assessment of flaws found during fatigue test and/or teardown inspections regressed to zero cycles; or
- a distribution of fatigue damage determined from relevant fatigue testing and/or service experience.

4.3.4. Final cracking scenario

This is an estimate of the size and extent of multiple cracking that could cause residual strength to fall certification levels to the minimum required level as shown in A2-17. Techniques exist for 3-D elastic-plastic analysis of such problems; however, there are several alternative test and analysis approaches available that provide an equivalent level of safety. One such approach is to define the final cracking scenario as a subcritical condition (e.g. first crack at link-up at limit load). The use of a subcritical scenario reduces the complexity of the analysis and, in many cases, will not greatly reduce the total crack growth time, because the majority of the time taken to reach the critical condition is generally in the initiation phase.

4.3.5. Crack growth calculation

Progression of the crack distributions from the initial cracking scenario to the final cracking scenario should be developed. These curves can be developed:

- *analytically*, typically based on linear elastic fracture mechanics; or
- *empirically*, from test or service fractographic data.

4.3.6. Potential for Discrete Source Damage (DSD)

A structure susceptible to MSD/MED may also be affected by DSD due to an uncontained failure of high-energy rotating machinery (i.e. turbine engines). The approach described in this guidance material should ensure the MSD sizes and densities, that normally would be expected to exist at the structural modification point, would not significantly change the risk of catastrophic failure due to DSD.

4.3.7. Analysis methodology

Differences between multiple site damage and multiple element damage

Details of the approach used to characterise events leading up to WFD may be different. The differences will largely depend on whether multiple site damage or multiple element damage is being considered. This is especially true for crack interaction.

(a) Crack interaction

Multiple site damage has the potential for strong crack interaction, and the effect of multiple cracks on each other needs to be addressed. Multiple element damage, in most cases, does not have the same potential for strong crack interaction. The differences between interaction effects for multiple site damage and multiple element damage are illustrated in Figure A2-18.

(b) Multiple site damage and multiple element damage interaction

Some areas of an aeroplane are potentially susceptible to both multiple site damage and multiple element damage. Simultaneous occurrence of multiple site damage and multiple element damage is possible, even though it's not common. A comparison of inspection start points or modification start points might indicate the possibility of this occurrence. If so, the evaluation should consider interaction between multiple site damage and multiple element damage.

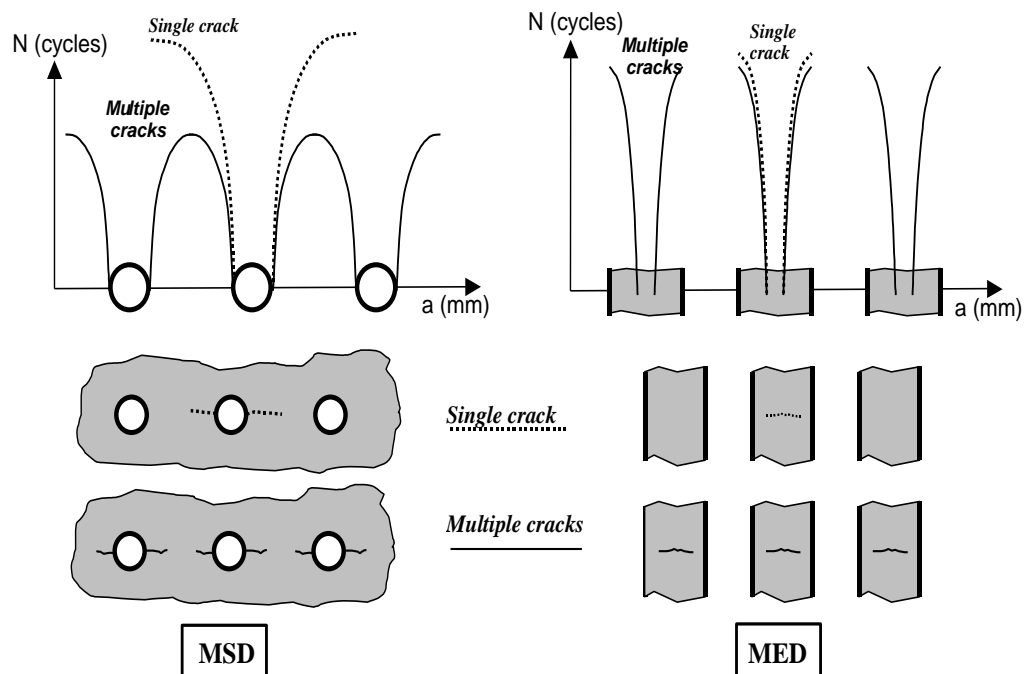

Figure A2-18: Difference between MSD and MED interaction effects

The evaluation methods used to determine the WFD average behaviour and associated parameters will vary. The report 'Recommendations for Regulatory Action to Prevent Widespread Fatigue Damage in the Commercial Aeroplane Fleet', Revision A, dated June 29, 1999 (a report of the AAWG for the ARAC's Transport Aircraft and Engine Issues Group), discusses two Round Robin exercises developed by the TCHs to provide insight into their respective methodologies. One outcome of the exercises was the identification of key assumptions or methods that had the greatest impact on the predicted WFD behaviour. These assumptions were:

- the flaw sizes assumed at initiation of crack growth phase of the analysis;
- material properties used (static, fatigue, fracture mechanics);
- ligament failure criteria;
- crack growth equations used;

- statistics used to evaluate the fatigue behaviour of the structure (e.g. time to crack initiation);
- methods of determining the structure modification point (SMP);
- detectable flaw size assumed;
- initial distribution of flaws; and
- factors used to determine bound behaviour as opposed to mean behaviour.

(c) Multiple element damage

When considering multiple element damage, where interaction between cracks in different elements is not a factor, the following should be considered:

(1) In a structure containing large numbers of similar elements there is not normally a high probability that, after a crack initiates in an element, a second crack will initiate in the element right next to it. If this does happen, however, the consequences to the overall structure may be severe. This is because having two structural members fail right next to each other can completely negate any ability of the structure to tolerate additional damage. Consequently, when performing an evaluation, make conservative assumptions and assume failures to be adjacent to each other.

(2) When an element fails completely, the load that has to be redistributed onto the non-failed structure can be large and can have a significant impact on the strength of both cracked and uncracked structure, therefore the effects of load redistribution must be included in the evaluation.

(d) Establishing maintenance actions

The following parameters are developed from paragraphs 4.3.2 through 4.3.7 above, and are necessary to establish an MSD/MED maintenance programme for the area under investigation.

Fatigue damage is the gradual deterioration of a material subjected to repeated loads. This gradual deterioration is a function of use and can be statistically quantified. The term WFD is used, and can be statistically quantified, at the end of the deterioration process — when the structure is no longer able to carry the residual strength loads. WFD can never be absolutely precluded because there is always some probability, no matter how small, that it will occur. Therefore, modifying or replacing structure at a predetermined, analytically-derived time stated in flight cycles or flight hours, minimises the probability of having WFD in the fleet. Modification or replacement is the most reliable method for precluding WFD. The point at which a modification is undertaken is referred to as the 'structural modification point' (SMP) and it is illustrated in Figure 6-3. The SMP is generally a fraction of the number representing the point in time when WFD (average behaviour) will occur, and should result in the same reliability as a successful two-lifetime fatigue test. This level of reliability for setting the SMP is acceptable if multiple site damage or multiple element damage inspections are shown to be effective in detecting cracks. If the inspections are effective, they must be implemented before the SMP. The implementation times for these inspections are known as the 'inspection start point.' Repeat inspections are usually necessary to maintain this effectiveness in detecting cracks. If multiple site damage or multiple element damage inspections are not effective in detecting cracks, then the SMP should be set at the time of inspection start point. For the purposes of this AMC, an inspection is effective if, when performed by

properly trained maintenance personnel, it will readily detect the damage in question⁵. The SMP should minimise the extent of cracking in the susceptible structural area in a fleet of affected aeroplanes. In fact, if this point is appropriately determined, a high percentage of aeroplanes would not have any multiple site damage or multiple element damage by the time the SMP is reached.

Due to the redundant nature of semi-monocoque structure, MED can be difficult to manage in a fleet environment. This stems from the fact that most aircraft structures are built-up in nature, and that makes the visual inspection of the various layers difficult. Also, visual inspections for MED typically rely on internal inspections, which may not be practical at the frequency necessary to preclude MED due to the time required to gain access to the structure. However, these issues are dependent on the specific design involved and the amount of damage being considered. In order to implement a viable inspection programme for MED, static stability must be maintained at all times and there should be no concurrent MED with MSD in a given structural area.

4.3.8. Inspection Start Point (ISP)

This is the point at which inspection starts if a monitoring period is used. Inspection is not practical for all applications and cannot replace the SMP. The ISP is determined through a statistical analysis of crack initiation based on fatigue testing, teardown, or service experience of similar structural details. It is assumed that the ISP is equivalent to a lower bound value with a specific probability in the statistical distribution of cracking events. Alternatively, the ISP may be established by applying appropriate factors to the average behaviour.

Inspection start point. If an inspection is determined to be effective, you will need to establish when those inspections should start. This point is illustrated in Figure 6-1. The start point is determined through a statistical analysis of crack initiation based on fatigue testing, teardown, or in-service experience of similar structure. The inspection start point is assumed to be equivalent to a lower-bound value with a specific probability in the statistical distribution of cracking events. Alternatively, an inspection start point may be established by applying appropriate factors (e.g. dividing the full-scale test result by a factor of 3) to the number representing WFD (average behaviour).

Inspection interval. The interval between inspections depends on the detectable crack size, the critical crack lengths and the probability that the cracks will be detected with the specific inspection method. Conservative scenarios should be assumed for developing the inspection interval unless other assumptions can be consistently supported by test and service experience.

⁵ The cracking identified in the FAA Airworthiness Directive (AD) 2002-07-09 is an example of the type of cracking that MSD inspections are effective in detecting. These cracks grow from the fastener holes in the lower row of the lower skin panel in such a way that the cracking is readily detectable using non-destructive inspection methods. The cracking identified in the FAA AD 2002-07-08 is an example of places where MSD inspections are not effective. These cracks grow in the outer surface and between the fastener holes in the lower row of the lower skin panel in such a way that the cracking is not readily detectable using non-destructive inspection methods. Modification is the only option to address this type of cracking.

4.3.9. Considerations:

~~Due to the redundant nature of semi-monocoque structure, MED can be difficult to manage in a fleet environment. This stems from the fact that most aircraft structures are built up in nature, and that makes the visual inspection of the various layers difficult. Also, visual inspections for MED typically rely on internal inspections, which may not be practical at the frequency necessary to preclude MED due to the time required to gain access to the structure. However, these issues are dependent on the specific design involved and the amount of damage being considered. In order to implement a viable inspection programme for MED, the following conditions must be met:~~

- ~~a) Static stability must be maintained at all times.~~
- ~~b) Large damage capability should be maintained.~~
- ~~c) There is no concurrent MED with MSD in a given structural area.~~

4.3.9.10. Structural Modification Point (SMP)

The SMP should be established as a point in time when structure should be modified or replaced to prevent WFD from occurring. This is typically established by:

- calculating when WFD would first occur in the structure (predicted using the WFD (average behaviour)).
- setting a time before the predicted occurrence of WFD to perform modifications or replacements that will prevent it.

The applicant should demonstrate that the proposed SMP established during the evaluation has the same confidence level as current regulations require for new certification. In lieu of other acceptable methods, the SMP can be established as a point reduced from the WFD (average behaviour), based on the viability of inspections in the monitoring period. The SMP can be determined by dividing the WFD (average behaviour) by a factor of 2 if there are viable inspections, or by a factor of 3 if inspections are not viable.

An aircraft should not be operated beyond the SMP unless the structure is modified or replaced, or unless additional approved data is provided that would extend the SMP. However, if during the structural evaluation for WFD a TCH/DAH finds that the flight cycles and/or flight hours SMP for a particular structural detail have been exceeded by one or more aircraft in the fleet, the TCH/DAH should expeditiously evaluate selected high-time aircraft in the fleet to determine their structural condition. From this evaluation, the TCH/DAH should notify the competent authorities and propose appropriate service actions.

As an example, the SMP may be determined by dividing the number representing the timing of when WFD (average behaviour) will occur by a factor of 2 if there are effective inspections, or by a factor of 3 if inspections are not effective.

A DAH may find that the SMP for a particular structural area has been exceeded by one or more aeroplanes in the fleet. In that case, the DAH should expedite the evaluation of those high-time aeroplanes to determine their structural condition and notify the airworthiness authorities and propose appropriate maintenance actions specific to those aeroplanes.

The initial SMP may be adjusted based on the following:

- (a) ~~Extension of SMP. In some cases, the SMP may be extended without changing the required reliability of the structure, i.e. projection to that of a two life time full scale fatigue test. These cases may generally be described under the umbrella of additional fatigue test evidence and include either or a combination of any or all of the following:~~ The tasks required to extend an SMP include the following:
- (1) Additional fatigue or residual strength tests, or both, on a full-scale aeroplane structure or a full-scale component followed by detailed inspections and analyses.
 - (2) Fatigue tests of new structure or structure from in-service aeroplanes on a smaller scale than full component tests (i.e. subcomponent or panel tests, or both). If a subcomponent test is used, the SMP would be extended only for that subcomponent.
 - (3) Teardown inspections (destructive) on structural components that have been removed from service.
 - (4) Teardown inspections (non-destructive) accomplished by selected, limited disassembly and subsequent reassembly of specific areas of high-time aeroplanes.
 - (5) Analysis of in-service data (e.g. inspections) from a statistically significant number of aeroplanes. ~~close to the original SMP showing no cracking compared with the predictions, taking into account future variability in service usage and loading compared to the surveyed aircraft. This data may be used to support increasing the original SMP by an amount that is agreed by the competent authority.~~
- (b) If cracks are found in the structural detail for which the evaluation was done during either the monitoring period or the modification programme, the SMP should be re-evaluated to ensure that the SMP does provide the required confidence level. If it is shown that the required confidence level is not being met, the SMP should be adjusted and the adjustment reflected in the appropriate Service Bulletins to address the condition of the fleet. Additional regulatory action may be required.

4.3.10. Inspection interval and method

An interval should be chosen to provide a sufficient number of inspections between the ISP and the SMP so that there is a high confidence that no MSD/MED condition will reach the final cracking scenario without detection. The interval is highly dependent on the detectable crack size and the probability of detection associated with the specific inspection method. If the crack cannot be detected, the SMP must be re-evaluated to ensure there is a high confidence level that no aircraft will develop MSD/MED before modification.

4.4. Evaluation of maintenance actions

For all areas that have been identified as susceptible to MSD/MED, the current maintenance programme should be evaluated to determine if adequate structural maintenance and inspection programmes exist to safeguard the structure against unanticipated cracking or other structural degradation. The evaluation of the current maintenance programme typically begins with the determination of the SMP for each area.

Each area should then be reviewed to determine the current maintenance actions and compare them to the maintenance needs established in this evaluation. Issues to be considered include the following:

- (a) Determine the inspection requirements (method, inspection start point, and repeat interval) of the inspection for each susceptible area (including that structure which is expected to arrest cracks) that is necessary to maintain the required level of safety.
- (b) Review the elements of the existing maintenance programmes already in place.
- (c) Revise and highlight elements of the maintenance programme necessary to maintain safety.

For susceptible areas approaching the SMP, where the SMP will not be increased or for areas that cannot be reliably inspected, a programme should be developed and documented that provides for replacement or modification of the susceptible structural area.

4.4.1. Period of WFD evaluation validity

At whatever point the WFD evaluation is made, it should support the LoV of the maintenance programme. Consistent with the use of test evidence to support individual SMPs, as described above in paragraph 4.3.9~~10~~, the LoV of the maintenance programme should be based on fatigue test evidence. For an existing ageing aircraft type, the initial WFD evaluation of the complete airframe will typically cover a significant forward estimation of the projected aircraft usage beyond its DSG, also known as the 'proposed ESG' and is effectively a proposed LoV. An evaluation through at least an additional 25 % of the DSG would provide a realistic forecast, with reasonable planning time for necessary maintenance action. However, it may be appropriate to adjust the evaluation validity period depending on issues such as:

- (a) the projected useful life of the aircraft at the time of the initial evaluation;
- (b) current non-destructive inspection (NDI) technology; and
- (c) airline advance planning requirements for introduction of new maintenance and modification programmes, to provide sufficient forward projection to identify all likely maintenance/modification actions essentially as one package.

Upon completion of the evaluation and publication of the revised maintenance requirements, the 'proposed ESG' becomes the LoV.

Note: This assumes that all other aspects of the maintenance programme that are required to support the LoV (such as SSID, CPCP, etc.) are in place and have been evaluated to ensure they too remain valid up to the LoV.

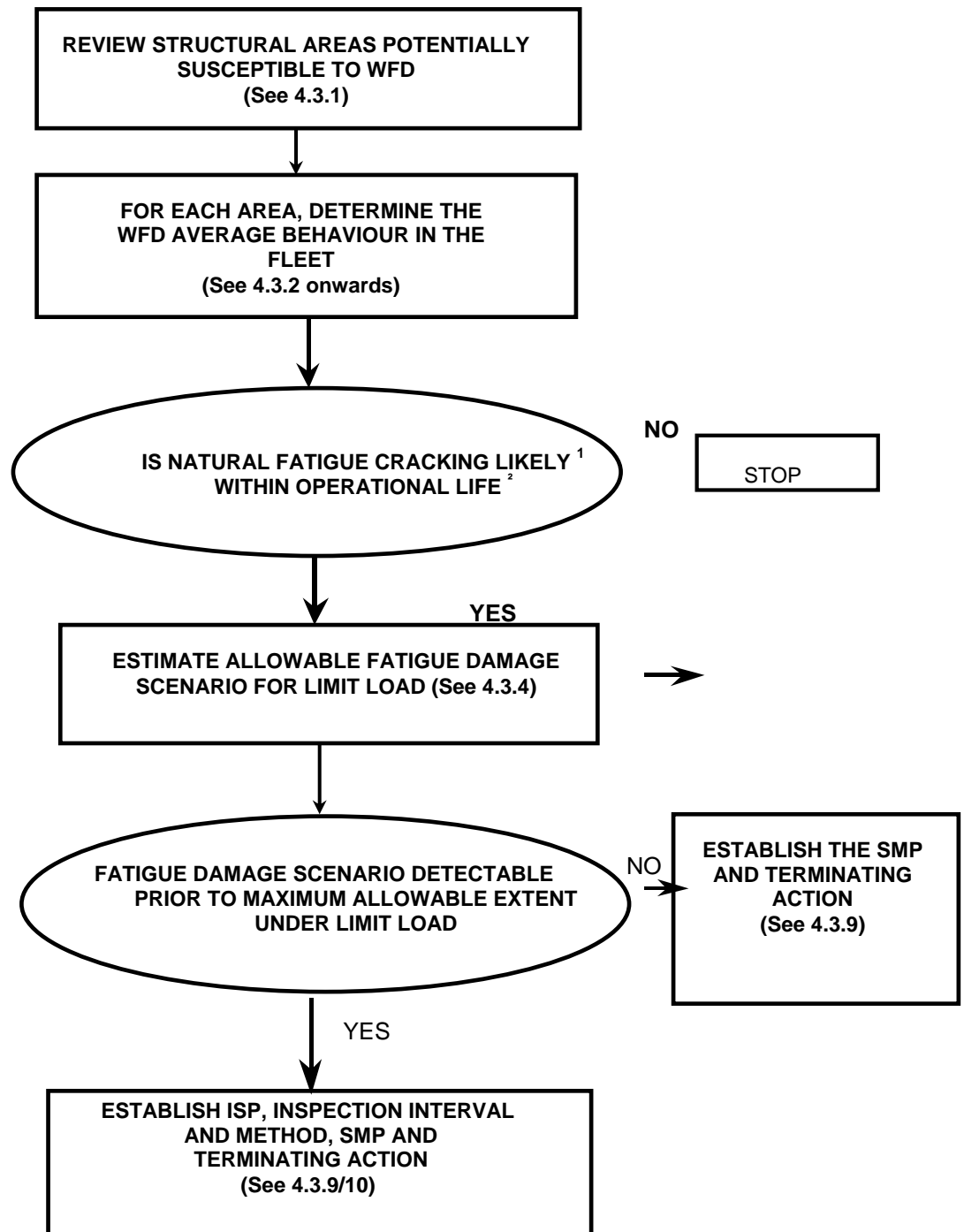

NOTES

1. Fatigue cracking is defined as likely if the factored fatigue life is less than the projected LoV of the aircraft at time of WFD evaluation.
2. The operational life is the projected LoV of the aircraft at time of WFD evaluation. (See 4.4.1)

Figure A2-19: Aircraft evaluation process

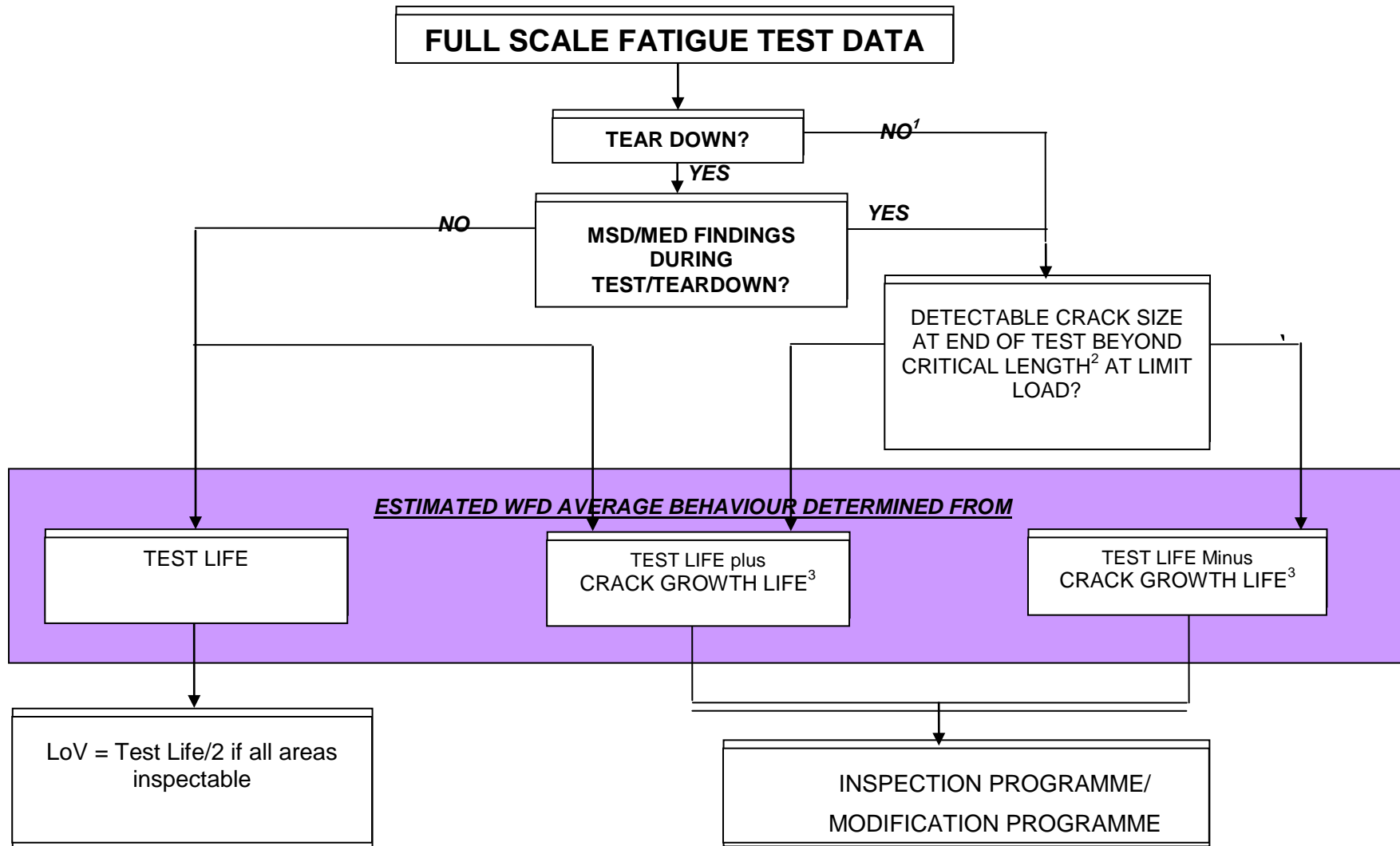

- 1 **ASSUMED STATE AT END OF TEST:** Best estimate of non-detected damage from inspection method used at the end of the test or during teardown.
- 2 **CRITICAL CRACK LENGTH:** First link-up of adjacent cracks at limit load (locally) or an adequate level of large damage capability.
- 3 **CRACK GROWTH LIFE:** Difference between assumed or actual state at the end of the test and critical crack length.

Figure A2- 20: Use of fatigue test and teardown information to determine WFD average behaviour

5. DOCUMENTATION

Any person seeking approval of an LoV of an aircraft type design should develop a document containing all the necessary ISPs, inspection procedures, replacement times, SMPs, and any other maintenance actions necessary to preclude WFD, and to support the LoV. That person must revise the SSID or ALS as necessary, and/or prepare Service Bulletins that contain the aforementioned maintenance actions. Since WFD is a safety concern for all operators of older aircraft, the Agency will make mandatory the identified inspection and modification programmes. In addition, the Agency may consider separate AD action to address any Service Bulletins or other service information publications revised or issued as a result of in-service MSD/MED findings resulting from implementation of these programmes.

The following items should be contained in the front of the documentation supporting the LoV:

- (a) identification of the variants of the basic aircraft type to which the document relates;
- (b) summary of the operational statistics of the fleet in terms of hours and flights;
- (c) description of the typical mission, or missions;
- (d) the types of operations for which the inspection programme is considered valid;
- (e) reference to documents giving any existing inspections, or modification of parts or components; and
- (f) the LoV of the maintenance programme in terms of flight cycles or flight hours or both as appropriate to accommodate variations in usage.

The document should contain at least the following information for each critical part or component:

- (a) description of the primary structure susceptible to WFD;
- (b) details of the monitoring period (inspection start point, repeat inspection interval, SMP, inspection method and procedure (including crack size, location and direction, and alternatives) when applicable;
- (c) any optional modification or replacement of the structural element as terminating action to inspection;
- (d) any mandatory modification or replacement of the structural element;
- (e) Service Bulletins (or other service information publications) revised or issued as a result of in-service findings resulting from the WFD evaluations (added as a revision to the initial WFD document); and
- (f) guidance to the operator on which inspection findings should be reported to the TCH/DAH, and appropriate reporting forms and methods of submission.

6. REPORTING REQUIREMENTS

Operators, TCHs and STC holders are required to report in accordance with various regulations (e.g. Part 21.3, Part 145.60). The regulations to which this AMC relates do not require any reporting requirements in addition to the current ones. Due to the potential

threat to structural integrity, the results of inspections must be accurately documented and reported in a timely manner to preclude the occurrence of WFD. The current system of operator and TCH communication has been useful in identifying and resolving a number of issues that can be classified as WFD concerns. MSD/MED has been discovered via fatigue testing and in-service experience. TCHs have been consistent in disseminating related data to operators to solicit additional service experience. However, a more thorough means of surveillance and reporting is essential to preclude WFD.

When damage is found while conducting an approved MSD/MED inspection programme, or at the SMP where replacement or modification of the structure is occurring, the TCHs, STC holders and the operators need to ensure that greater emphasis is placed on accurately reporting the following items:

- (a) a description (with a sketch) of the damage, including crack length, orientation, location, flight cycles/hours, and condition of structure;
- (b) results of follow-up inspections by operators that identify similar problems on other aircraft in the fleet;
- (c) findings where inspections accomplished during the repair or replacement/modification identify additional similar damage sites; and
- (d) adjacent repairs.

Operators must report all cases of MSD/MED to the TCH, STC holder or the competent authority as appropriate, irrespective of how frequently such cases occur. Cracked areas from in-service aircraft (damaged structure) may be needed for detailed examination. Operators are encouraged to provide fractographic specimens whenever possible. Aeroplanes undergoing heavy maintenance checks are perhaps the most useful sources for such specimens.

Operators should remain diligent in the reporting of potential MSD/MED concerns not identified by the TCH/DAH. Indications of a developing MSD/MED problem may include:

- (a) damage at multiple locations in similar adjacent details;
- (b) repetitive part replacement; or
- (c) adjacent repairs.

Documentation will be provided by the TCH and STC holder as appropriate to specify the required reporting format and time frame. The data will be reviewed by the TCH or STC holder, operator(s), and the Agency to evaluate the nature and magnitude of the problem and to determine the appropriate corrective action.

7. WFD EVALUATION FOR STRUCTURAL MODIFICATIONS AND REPAIRS

7.1. Background

In principle, all major modifications (STCs) and repairs that create, modify, or affect structure that is susceptible to MSD/MED should be evaluated to demonstrate freedom from WFD in the airframe assuming that all necessary maintenance actions are in place that are required in order to safely reach the LoV. Typically designers have minimised WFD in practice through adherence to design criteria for durability and economic reasons that often preclude WFD up to at least the DSG. While this is not true in all cases (as witnessed by numerous ADs addressing MSD and MED), it is fair to say that lessons have been learned.

The risk of WFD in existing repairs and modifications (changes) with DTI implemented following a DTE according to their certification basis, or Part 26.320, or Part 26.330, or FAA Part 26 requirements, is considered remote. Nonetheless, if the LoV is subsequently extended, assumptions made by the TCH supporting this extension may be invalidated by existing and new repairs.

In the context of the EASA DAH requirements for DT evaluation of existing repairs this means that up to the first LoV published in compliance with the EASA ageing aircraft regulation Part 26.300, no additional F&DT analysis is required beyond that approved for compliance with FAR Part 26 or Part 26.320 and 26.330 unless the certification basis is CS 25. Amdt X or equivalent or later.

In any case, when certifying repairs or modifications to structure originally certified to earlier amendments of CS and JAR requirements the associated ACJ or AMC should be considered, e.g. this approach is outlined in JAR 25 ACJ 25.571(a) 2.1.1 d.:

'Provisions to limit the probability of concurrent multiple damage, particularly after long service, which could conceivably contribute to a common fracture path. The achievement of this would be facilitated by ensuring sufficient life to crack initiation. Examples of such multiple damage are:

- (i) A number of small cracks which might coalesce to form a single long crack;
- (ii) Failures, or partial failures, in adjacent areas, due to the redistribution of loading following a failure of a single element; and
- (iii) Simultaneous failure, or partial failure, of multiple load path discrete elements, working at similar stress levels.

In practice it may not be possible to guard against the effects of multiple damage and fail-safe substantiation may be valid only up to a particular life which would preclude multiple damage.'

This practice as followed by some approval holders for many years is similar to declaring an SMP.

Nonetheless, in accordance with Part 26.350 those existing changes and repairs intended to remain on the aircraft up to an extended LoV should be evaluated for fatigue and damage tolerance including WFD and maintenance actions provided to preclude catastrophic failure up to the aircraft's LoV. Maintenance actions could mean modification, replacement and/or inspections. New applications for repairs and changes applicable to a type with an extended LoV must also comply with Part 26.350.

Many DAHs have historically assessed WFD type cracking scenarios using simple assumptions and criteria that have proved very effective, especially for limited areas of structure.

Repairs that deserve particular attention and may attract an SMP are:

- (a) long lengths of repaired or replaced skin splice;
- (b) any repair that affects more than two frame bays; and

(c) multiple adjacent repairs.

The following Acceptable Means of Compliance are provided for repairs complying with Part 26.350 and that are designed using similar principles to the baseline structure.

The first step is to evaluate susceptibility of the repair to WFD in a similar way to that of the baseline structure. Also checking existing inspection requirements in the repaired area, utilising the ALS of the ICA, the structural inspections of the maintenance programme and any applicable ADs or Service Bulletins.

If the repair location and repair are not considered susceptible to WFD then inspections still need to be developed assuming rational cracking scenarios and means of developing thresholds appropriate to the certification basis.

No specific WFD evaluation is required for an isolated repair where the crack length visible beyond the reinforcing doubler can be detected in a safe and practical inspection period assuming a critical crack arising from MSD is fully developed under the doubler and such damage can be shown not to lead to rapid decompression of the aircraft or severe fuel leak. DT evaluation and associated inspection requirements can be based on the detectable crack beyond the doubler and the associated residual strength.

For repairs less than two frame bays, if the repair is being applied at a point in the aircraft's life greater than one half of the current LoV, no SMP is required, provided practical detailed inspections are derived based on cracking scenarios, including MSD, likely to arise in the remaining life of the repair. Thresholds for these inspections may be set using a calculated mean fatigue SN life of the WFD-susceptible area of the repair divided by 5, provided all out-of-plane bending effects have been accounted for in a rational or conservative manner, or where there is supporting representative test evidence a scatter factor of 3 may be used.

For existing isolated fuselage skin repairs comprised of reinforcing doublers less than two frame bays in length no SMP is required to be established provided practical detailed inspections are derived based on cracking scenarios likely to arise in the remaining life of the repair.

As is always the case, if the inspection interval is too short or the probability of detection questionable, then modification or replacement may be the only solution. Thresholds for these inspections may be set using the calculated mean fatigue SN life of the WFD-susceptible area of the repair divided by 5 provided all out-of-plane bending effects have been accounted for in a rational or conservative manner.

For existing repairs on an aircraft for which an extension of the LoV is sought the threshold should be calculated from the point of application of the repair. If this is not known, the repair should be inspected upon reaching the LoV unless a threshold calculated assuming the repair was applied when the aircraft was first delivered is greater.

If the above approaches are not possible, in order to limit the probability of concurrent multiple damage, particularly after long service, the repair should be designed with sufficient life to crack initiation to exceed the LoV from the point of repair implementation or a life limit (repair replacement) imposed.

For certain existing modifications, DAHs supporting an extension of an LOV must perform a WFD evaluation according to Part 26.350.

The operator is responsible together with the DAH for ensuring the accomplishment of appropriate evaluations for each modified aircraft. The operator may first need to conduct an assessment on each of its aircraft to determine what modifications or repairs exist and would be susceptible to MSD/MED. The following are some examples of types of modifications and repairs that present such concerns:

- (a) passenger-to-freighter conversions (including addition of main deck cargo doors);
- (b) gross weight increases (increased operating weights, increased zero fuel weights, increased landing weights and increased maximum take-off weights);
- (c) installation of fuselage cut-outs (passenger entry doors, emergency exit doors or crew escape hatches, fuselage access doors and cabin window relocations);
- (d) complete re-engine and/or pylon modifications;
- (e) engine hush kits and nacelle modifications;
- (f) wing modifications, such as the installation of winglets or changes in flight control settings (flap droop), and changes to wing trailing edge structure;
- (g) modified or replaced skin splice;
- (h) any modification that affects several frame bays; and
- (i) multiple adjacent modifications repairs.

Other potential areas that must be considered include:

- (a) a modification that covers structure requiring periodic inspection by the operator's maintenance programme (modifications must be reviewed to account for the differences with TCH baseline maintenance programme requirements);
- (b) a modification that results in operational mission change that significantly changes manufacturer's load/stress spectrum (for example, a passenger-to-freighter conversion); and
- (c) a modification that changes areas of the fuselage from being externally inspectable using visual means to being uninspectable (for example, a large external fuselage doubler that resulted in hidden details, rendering them visually uninspectable).

Consideration must be given to mods following similar processes to those given in section 4 above. Guidance on the supporting test evidence required is given in AMC to CS 25.571.

8. RESPONSIBILITY FOR WFD EVALUATION

While the primary responsibility is with the DAH to perform the analyses and supporting tests. However it is expected that where extensive maintenance actions will be necessary, the practicality of their implementation will be evaluated in a cooperative effort between the operators and TCHs/DAHs, with participation of the Agency.

ANNEX 1

FULL-SCALE FATIGUE TEST EVIDENCE

Contents

- (a) Overview
- (b) Full-scale fatigue test evidence
- (c) Key elements of a full-scale fatigue test programme
 - (1) Article
 - (2) Test set-up and loading
 - (i) Test set-up
 - (ii) Test loading
 - (3) Test duration
 - (i) New type certificates and derivatives
 - (ii) Repairs and type design changes
 - (4) Post-test evaluation
 - (i) Residual strength tests
 - (ii) Teardown inspections
- (d) Scope of full-scale fatigue test article
 - (1) New type designs
 - (2) Derivative models
 - (3) Type design changes — Service Bulletins
 - (4) Type design changes — Supplemental type certificates (STC)
 - (5) Major repairs
- (e) Use of existing full-scale fatigue test data
- (f) Use of in-service data

(a) Overview

CS 25.571(b) Amdt X requires that special consideration for WFD be included where the design is such that this type of damage could occur. CS 25.571(b) Amdt X requires the effectiveness of the provisions to preclude the possibility of WFD occurring within the limits of validity of the maintenance programme to be demonstrated with sufficient full-scale fatigue test evidence. The determination of what constitutes 'sufficient full-scale test evidence' requires a considerable amount of engineering judgment and is a matter that should be discussed and agreed to between an applicant and EASA early in the planning stage of a certification project.

(b) Full-scale fatigue test evidence

In general, sufficient full-scale fatigue test evidence consists of full-scale fatigue testing to at least two times the LoV, followed by specific inspections and analyses to determine that WFD has not occurred. The following factors should be considered in determining the sufficiency of the evidence:

Factor 1: The comparability of the load spectrum between the test and the projected usage of the aeroplane.

Factor 2: The comparability of the airframe materials, design and build standards between the test article and the certified aeroplane.

Factor 3: The extent of post-test teardown inspection and analysis for determining if widespread fatigue cracking has occurred.

Factor 4: The duration of the fatigue testing.

Factor 5: The size and complexity of a design or build standard change. This factor applies to design changes made to a model that has already been certified and for which full-scale fatigue test evidence for the original structure should have already been determined to be sufficient. Small, simple design changes, comparable to the original structure, could be analytically determined to be equivalent to the original structure in their propensity for WFD. In such cases, additional full-scale fatigue test evidence should not be necessary.

Factor 6: In the case of major changes and STCs, the age of an aeroplane being modified. This factor applies to aeroplanes that have already accumulated a portion of their design service goal prior to being modified. An applicant should only be required to demonstrate freedom from WFD up to the LoV in place for the original aeroplane.

(c) Key elements of a full-scale fatigue test programme

The following guidance addresses key elements of a test programme that is intended to generate the data necessary to support compliance. It is generally applicable to all certification projects.

- (1) Article. The test article should be representative of the structure of the aeroplane to be certified (i.e. ideally a production standard article). The attributes of the type design that could affect MSD/MED initiation, growth and subsequent residual strength capability should be replicated as closely as possible on the test article. Critical attributes include, but are not limited to, the following:
 - material types and forms,
 - dimensions,
 - joining methods and details,
 - coating and plating,
 - use of faying surface sealant,
 - assembly processes and sequences, and
 - influence of secondary structure (e.g. loads induced due to proximity to the structure under evaluation).
- (2) Test set-up and loading. The test set-up and loading should result in a realistic simulation of expected operational loads.
 - (i) Test set-up. The test set-up dictates how loads are introduced into the structure and reacted. Every effort should be made to introduce and react loads as realistically as possible. When compromise is made (e.g. wing air loading) the resulting internal loads should be evaluated (e.g. using finite element methods) to ensure that the structure is not being unrealistically underloaded or overloaded locally or globally.
 - (ii) Loading spectrum. The test loading spectrum should include loads from all damaging sources (e.g. cabin pressurisation, maneuvers, gusts, engine thrust, control surface deflection, landing impact) that are significant for the structure being evaluated. Consideration should also be given to temperature and other environmental effects that may affect internal loads. Supporting rationale should be provided when a load source is not represented in a sequence. Additionally, differences between the test sequence and expected operational sequence should be justified. For example it is standard practice to eliminate low loads that are considered to be non-damaging and clip high infrequent loads that may unconservatively bias the outcome, but care should be taken in both cases so that the test results are representative.
- (3) Test duration. AMC 20-20 includes guidance on how to establish mandatory maintenance actions for WFD-susceptible structure needed to preclude an occurrence of WFD in that structure. For any WFD-susceptible area the average time in flight cycles and/or hours to develop WFD must first be determined. This is referred to as the WFD (average behaviour) for the subject area. The AMC 20-20 guidance states that the area should be modified/replaced at one third of this time unless inspection for MSD/MED is practical. If inspection is practical the guidance states that inspection should start at one third of the WFD (average behaviour) with modification/replacement at one half of that time. It is standard practice to interpret the unfactored fatigue life of one specimen as the average life. It follows that if one full-scale fatigue test article survives a test duration of X time without an occurrence of WFD it can be conservatively assumed that the WFD (average behaviour) of all susceptible areas is equal to X. Based on this and assuming that the susceptible areas are impractical to inspect for MSD/MED, the

guidance of AMC 20-20 would require that replacement/modification be implemented at X/3. For areas where MSD/MED inspections were practical replacement/modification could be deferred until X/2, but MSD/MED inspections would have to start at X/3. The procedure should be kept in mind when deciding what the test duration will be.

- (4) Post-test evaluation. One of the primary objectives of the full-scale fatigue test is to generate data needed to determine the absolute WFD (average behaviour) for each susceptible area or establish a lower bound. Recall that the definition of WFD (average behaviour) is the average time required for MSD/MED to initiate and grow to the point that the static strength capability of the structure is reduced below the residual strength requirements of § 25.571(b). Some work is required at the end of the test to determine the strength capability of the structure either directly or indirectly.
- (i) Residual strength tests. The direct way to demonstrate freedom from WFD at the end of a full-scale fatigue test is to subject the article to the required residual strength loads specified in § 25.571(b). If the test article sustains the loads it can be concluded that the point of WFD has yet to be reached for any areas. However, because fatigue cracks that might exist at the end of the test are not quantified it is not possible to determine how far beyond the test duration WFD would occur in any of the susceptible areas without accomplishing additional work (e.g. teardown inspection). Additionally, metallic test articles may be unconservatively compromised relative to their future fatigue performance if static loads in excess of representative operational loads are applied. Residual strength testing could preclude the possibility of using an article for additional fatigue testing.
- (ii) Teardown inspections. The residual strength capability may be evaluated indirectly by performing teardown inspections to quantify the size of any MSD/MED cracks that might be present or to establish a lower bound on crack size based on inspection method capability. Once this is done the residual strength capability can be estimated analytically. Depending on the results crack growth analyses may also be required to project backwards or forwards in time to estimate the WFD (average behaviour) for an area. As a minimum teardown inspection methods should be capable of detecting the minimum size of MSD or MED cracking that would result in a WFD condition (i.e. residual strength degraded below the level specified in 25.571(b)). Ideally it is recommended that inspection methods be used that are capable of detecting MSD/MED cracking before it degrades strength below the required level. Effective teardown inspections required to demonstrate freedom from WFD typically require significant resources. They typically require disassembly (e.g. fastener removal) and destruction of the test article. All areas that are or may be susceptible to WFD should be identified and examined.

(d) Scope of full-scale fatigue test article

The following examples offer some guidance on the types of data sets that might constitute 'sufficient evidence' for some kinds of certification projects. The scope of the test specimen and the duration of the test are considered.

- (1) New type designs. Normally this type of project would necessitate its own full-scale fatigue test of the complete airframe to represent the new structure and its

loading environment. Nevertheless, prior full-scale fatigue test evidence from earlier tests performed by the applicant, or others, may also be used and could supplement additional tests on the new model. Ultimately, the evidence needs to be sufficient to conclude with confidence that, within the design service goal of the airframe, WFD will not occur. Factors 1 through 4 should be considered in determining the sufficiency of the evidence.

A test duration of a minimum of twice the design service goal for the aeroplane model would normally be necessary if the loading spectrum is realistic, the design and construction for the test article principal structure is the same as for the certified aeroplane, and post-test teardown is exhaustive. If conformance to Factors 1 through 3 is less than ideal, a significantly longer test duration would be needed to conclude with confidence that WFD will not occur within the design service goal. Moreover, no amount of fatigue testing will suffice if conformance to Factors 1 through 3 above is not reasonable. Consideration should also be given to the possible future need for life extension or product development, such as potential weight increases, etc.

- (2) Derivative models: The default position would be to test the entire airframe. However, it may be possible to reliably determine the occurrence of WFD for part or all of the derivative model from the data that the applicant generated or assembled during the original certification project. Nevertheless, the evidence needs to be sufficient to allow confidence in the calculations which show that WFD will not occur within the design service goal of the aeroplane. Factors 1 through 5 should be considered in determining the sufficiency of the evidence for derivative models. For example, a change in structural design concept, a change in aerodynamic contour, or a modification of structure that has a complex internal load distribution might well make analytical extrapolation from the existing full-scale fatigue test evidence very uncertain. Such changes might well necessitate full-scale fatigue testing of the actual derivative principal structure. On the other hand, a typical derivative often involves extending the fuselage by inserting 'fuselage plugs' that consist of a copy of the typical semi-monocoque construction for that model with slightly modified material gauges. Normally this type of project would not necessitate its own full-scale fatigue test, particularly if very similar load paths and operating stress levels are retained.
- (3) Type design changes — Service Bulletins. Normally this type of project would not necessitate its own full-scale fatigue test because the applicant would have generated, or assembled, sufficient full-scale fatigue test evidence during the original certification project that could be applied to the change. Nevertheless, as cited in the previous example, the evidence needs to be sufficient to allow confidence in the calculations which show that WFD will not occur within the design service goal of the aeroplane. In addition, Factor 5 'The size and complexity of a design change' should be considered.
- (4) Type design changes — Supplemental type certificates (STC)
- (i) Sufficient full-scale test evidence for structure certified under an STC may necessitate additional full-scale fatigue testing, although the extent of the design change may be small enough to use Factor 5 to establish the sufficiency of the existing full-scale fatigue test evidence. In addition, although the applicant for an STC may not have access to the original equipment manufacturer's full-scale fatigue test data, the applicant may

assume that the basic structure was shown to comply with the regulation, unless EASA has taken, or intends to take, Airworthiness Directive (AD) action to alleviate a WFD condition. This assumption implies that sufficient full-scale fatigue test evidence exists, demonstrating that WFD will not occur within the design service goal of the aeroplane. For the purpose of the STC applicant's demonstration, it may be assumed that model types certified under CS 25.571 and which are not subject to AD action to alleviate a WFD condition, have received two full design service goals of fatigue testing, under realistic loads, and have received a thorough post-test inspection that did not detect any WFD. With this assumption, and Factors 1 through 5, the STC applicant may be able to demonstrate that WFD will not occur on its modification (or the underlying original structure) within the design service goal. If, however, the modification significantly affects the distribution of stress in the underlying structure, or significantly alters loads in other parts of the aeroplane, or significantly alters the intended mission of the aeroplane, or if the modification is significantly different in structural concept from the certified aeroplane being modified, additional representative fatigue test evidence would be necessary.

- (ii) In addition, Factor 6 'The age of the aeroplane being modified' comes into play for modifications made to older aeroplanes. The STC applicant should demonstrate freedom from WFD up to the LoV of the aeroplane being modified. For example, an applicant for an STC to an aeroplane that has reached an age equivalent to 75 per cent of its LoV should demonstrate that the modified aeroplane will be free from WFD for at least the remaining 25 per cent of the LoV. Although an applicant could attempt to demonstrate freedom from WFD for a longer period, this may not be possible unless the original equipment manufacturer cooperates by providing data for the basic structure. A short design service goal for the modification could simplify the demonstration of freedom from WFD for the STC applicant. Nevertheless, the applicant should also be aware that the LoV of the aeroplane is not a fixed life; it may be extended as a result of a structural re-evaluation and service action plan, such as it has been developed for certain models under EASA's and FAA's 'Aging Aeroplane Programme'. Unless the modifier also re-evaluates its STC modification, the shorter goal for the modification could impede extending the design service goal of the modified aeroplanes.

- (5) Major repairs. New repairs that differ from repairs contained in the original equipment manufacturer's structural repair manual, but that are comparable in design to such repairs, and that meet CS-25 requirements in other respects, would not necessitate full-scale fatigue testing to support freedom from WFD up to the LoV. For TCH repairs, only extensive major repair solutions (that may be susceptible to WFD) and that utilise different design concepts from the type design would require further testing.

- (e) Use of existing full-scale fatigue test data

In some cases, especially for derivative models and type design changes accomplished by the type certificate holder, there may be existing full-scale fatigue test data that

may be used to support compliance and mitigate the need to perform additional testing.

Any physical differences between the structure originally tested and the structure being considered that could affect its fatigue behaviour must be identified and reconciled. Differences that should be addressed include, but are not limited to, differences in any of the physical attributes listed under point (b)(1) of this Appendix and differences in operational loading. Typical developments that affect the applicability of the original LoV demonstration data are:

- gross weight (e.g. increases),
- cabin pressurisation (e.g. change in maximum cabin or operating altitude),
- flight segment parameters.

The older the test data, the harder it may be to demonstrate that it is sufficient. Often test articles were not conformed, neither were test plans or reports submitted to EASA as part of the compliance data package. Loading sequence rigor varied significantly over the years and from OEM to OEM. Additionally, testing philosophies and protocols were not standardised. For example post-test evaluations, if any, varied significantly and in some cases consisted of nothing more than limited visual inspections. However, there may be acceptable data from early full-scale fatigue tests that the applicant proposes to use to support compliance. In order to use such data the configuration of the test article and loading must be verified and the issue of the residual strength capability of the article (or teardown data) at the end of the test must be addressed.

- (f) Use of in-service data. There may be in-service data that can be used to support WFD evaluations. Examples of such data are as follows:
- Documented positive findings of MSD/MED cracks that include location, size and the time in service of the affected aeroplane along with a credible record of how the aircraft had been operated since original delivery.
 - Documented negative findings from in-service inspections for MSD/MED cracks on a statistically significant number of aeroplanes with the time in service of each aircraft and a credible record of how each aircraft had been operated since original delivery. For this data to be useful the inspections methods used should have been capable of detecting MSD/MED crack sizes equal to or smaller than those sizes that could reduce the strength of the structure below the residual strength levels specified in CS 25.571(b).
 - Documented findings from the destructive teardown inspection of structure from in-service aircraft. This might be structure (e.g. fuselage splices) removed from the aircraft that were subsequently returned to service or from retired aircraft. It would also be necessary to have a credible record of the operational loading experienced by the subject structure up to the time it was taken out of service.

Prior to using in-service data any physical and loading differences that exist between the structure of the in-service or retired aeroplanes and the structure being certified should be identified and reconciled as discussed above.

ANNEX 2

EXAMPLE OF HOW TO ESTABLISH AN LOV

This Annex provides a simplified example of how to establish an LoV for a specified aeroplane structural configuration. **The process for establishing an LoV involves four steps:**

Step 1. Identifying a candidate LoV for the aeroplane structural configuration.

Step 2. Identifying WFD-susceptible structure. For this evaluation it was determined that the aeroplane structural configuration had six areas with WFD-susceptible structure.

Step 3. Performing a WFD evaluation for each of the six areas of WFD-susceptible structure to determine whether there are inspection start points and structural modification points for the candidate LoV identified. This allows evaluation of the candidate LoV.

Figure 2-1, shown below, shows the WFD behaviour for one WFD-susceptible area. The figure also shows three different candidate LoVs. Candidate LoV1 is at a point that occurs significantly before the WFD average behaviour line. This LoV won't require any maintenance actions. Candidate LoV2 occurs before the WFD average behaviour line, but closer to it. As a result, inspection will need to start before the LoV. Although candidate LoV3 occurs before the WFD average behaviour line, with this LoV the probability of WFD in the fleet is unacceptable and inspection and subsequent modification or replacement is required before the aeroplane reaches LoV3. Note that for LoV2 and LoV3, if inspections were determined to be unreliable, then the SMP would occur at the point on the chart where the ISP is. Using this example, this decision-making process needs to be repeated for all six WFD-susceptible areas.

Evaluate candidate LoVs and results of WFD evaluations for each susceptible area.

Figure 2-1: Comparison of WFD-susceptible structure to aircraft LoV

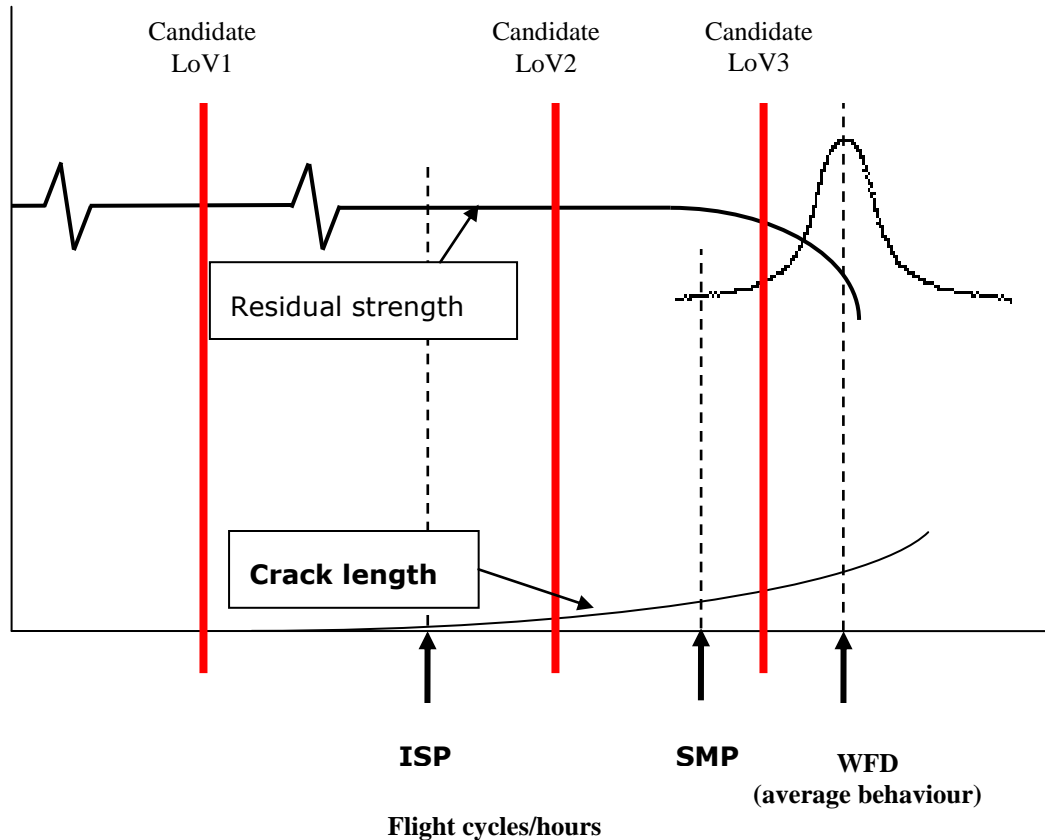

Step 4. Finalising the LoV. Once all susceptible areas have been evaluated, the final step is to determine where to establish the LoV that will be proposed for compliance (204.d.). Figure 7-2 shows the results of the WFD evaluation of the six WFD-susceptible areas. As it is shown, there are inspections and modifications or replacements that must be performed over time to preclude WFD. Any LoV can be valid as long as it is demonstrated that, based on its inherent fatigue characteristics and any required maintenance actions, the aeroplane model will be free from WFD up to the LoV. The example in Figure 2-2 includes three LoVs that could be proposed for compliance.

- LoV1: Maintenance actions are not required to address WFD.
- LoV2: Inspection and modification or replacement of area four are required to address WFD.
- LoV3: The design approval holder may propose an LoV that is greater than LoV2. However, as shown in Figure 2-2, that would result in more maintenance actions than identified for LoV2. Operators would be required to perform maintenance

actions in five out of the six WFD-susceptible areas. Areas 1, 2 and 4 will have to be inspected prior to the LoV. Areas 3 and 5 are free from WFD maintenance actions. Area 4 would be required to be inspected and modified, and then the modification would be required to be inspected prior to the LoV. Area 6 would require modification prior to reaching the LoV. Some of the maintenance actions required for the LoV may have already been issued in a Service Bulletin and mandated by an Airworthiness Directive. For the rest, Airworthiness Directives will need to be issued.

Figure 2-2: Aeroplane maintenance actions

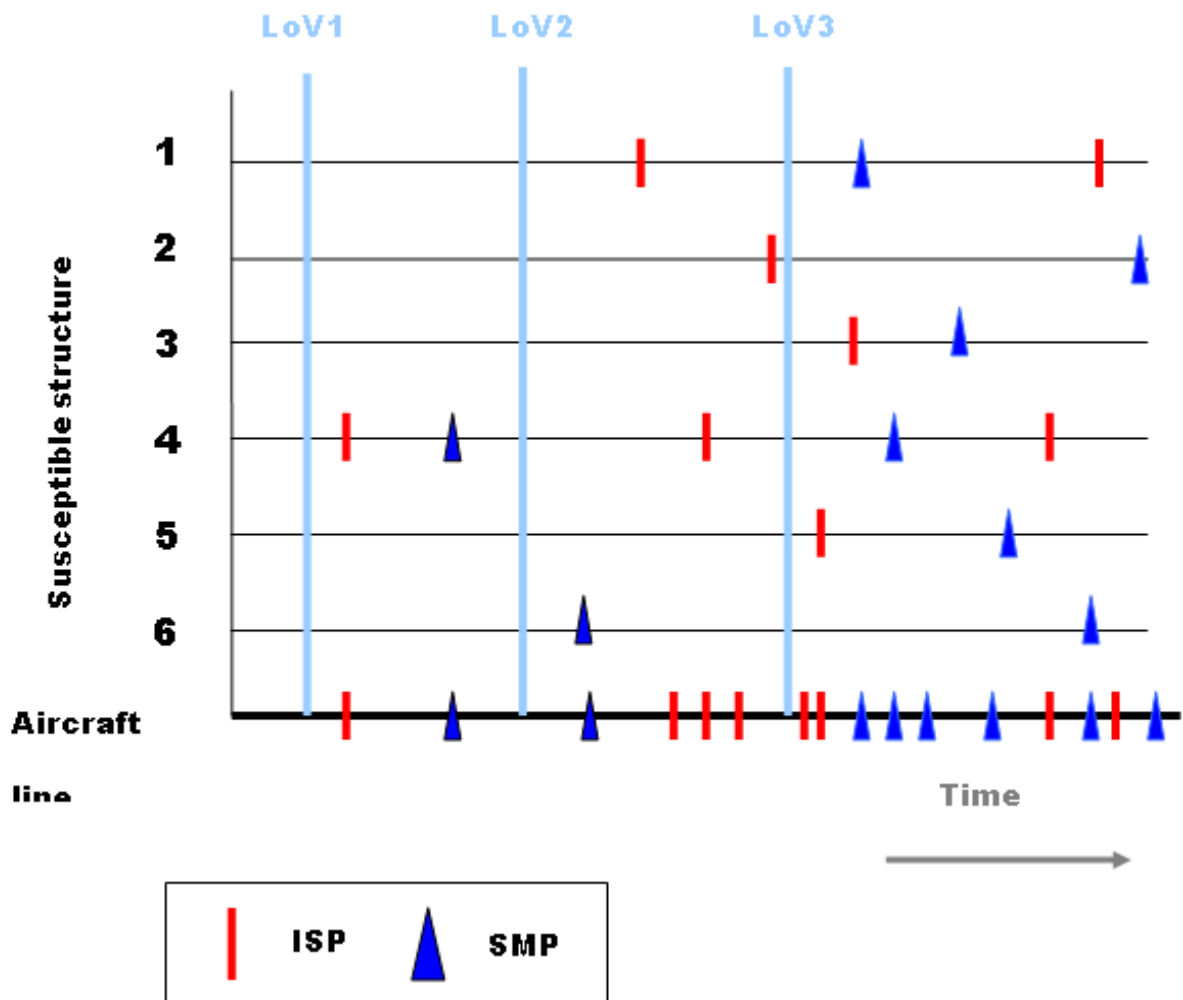

APPENDIX 3

GUIDELINES FOR ESTABLISHING INSTRUCTIONS FOR CONTINUED AIRWORTHINESS OF STRUCTURAL REPAIRS AND MODIFICATIONS

1. INTRODUCTION

With an SSID, CPCP, mandatory modifications and LoV in place an individual aircraft may still not meet the intended level of airworthiness for ageing aircraft structures. Repairs and modifications to aircraft structure also warrant investigation. It is recommended that for large transport aeroplanes all repairs and modifications that affect FCS should be assessed using some form of damage tolerance-based evaluation. A regulatory requirement for damage tolerance was not applied to aeroplane design types certified before 1978, and even after this time implementation of DTE on repairs and modifications was not consistent. Therefore, the damage tolerance characteristics of repairs and modifications may vary widely and are largely unknown. In view of these concerns it is necessary to perform an assessment of repairs and modifications on aircraft in service to establish their damage tolerance characteristics.

Part 26.320 through 26.370 define which repairs and modifications must be addressed using damage tolerance.

The need to address WFD for certain repairs and modifications is addressed in Appendix 2 above.

2. DEFINITIONS

For the purposes of this Appendix, the following definitions apply:

- **Damage Tolerance Data (DTD)** are damage tolerance evaluation (DTE) documentation and damage tolerance inspections (DTIs).
- **Damage Tolerance Evaluation (DTE)** is a process that leads to a determination of maintenance actions necessary to detect or preclude fatigue cracking that could contribute to a catastrophic failure. As applied to repairs and modifications, a DTE includes the evaluation of the repair or modification and the fatigue-critical structure affected by the repair or modification. The process utilises the damage tolerance procedures as described in CS-25 AMC 25.571.
- **Damage Tolerance Inspections (DTIs)** are the inspections developed as a result of a DTE. A DTI includes the areas to be inspected, the inspection method, the inspection procedures, including acceptance and rejection criteria, the threshold, and any repeat intervals associated with those inspections. DTIs may specify a time limit when a repair or modification needs to be replaced or modified. If the DTE concludes that DT-based supplemental structural inspections are not necessary, the DTI documentation should include a statement that the normal zonal inspection programme is sufficient.
- **Fatigue-Critical Baseline Structure (FCBS)** is the baseline structure of the aircraft that is classified as fatigue-critical structure.

3. ESTABLISHMENT OF A DAMAGE TOLERANCE-BASED INSPECTION PROGRAMME FOR REPAIRS AFFECTING FCS

Repairs are a concern on older aircraft because of the possibility that they may develop, cause, or obscure metal fatigue, corrosion, or other damage during service. This damage might occur within the repair itself or in the adjacent structure and might ultimately lead to structural failure.

In general, repairs present a more challenging problem to solve than the original structure because they are unique and tailored in design to correct particular damage to the original structure. While the performance of the original structure may be predicted from tests and from experience on other aircraft in service, the behaviour of a repair and its effect on the fatigue characteristics of the original structure are generally known to a lesser extent than for the basic unrepaired structure.

Repairs may be of concern as time in service increases for the following reasons:

As aircraft age, both the number and age of existing repairs increase. Along with this increase is the possibility of unforeseen repair interaction, failure, or other damage occurring in the repaired area. The continued operational safety of these aircraft depends primarily on a satisfactory maintenance programme (inspections conducted at the right time, in the right place, using the most appropriate technique, or in some cases replacement of the repair). To develop this programme, a damage tolerance evaluation of repairs to aircraft structure is essential. The longer an aircraft is in service, the more important this evaluation and a subsequent inspection programme become.

The practice of repair justification has evolved gradually over the last 20 plus years. Some repairs described in the aircraft manufacturers' SRMs were not designed to fatigue and damage tolerance principles (Ref. AAWG Report: Recommendations concerning ARAC taskings FR Doc 04-10816; Aging Aircraft Safety Final Rule. 14 CFR 121.370a and 129.16.). Repairs accomplished in accordance with the information contained in the early versions of the SRMs may require additional inspections if evaluated using the fatigue and damage tolerance methodology.

Damage tolerance is a structural design and inspection methodology used to maintain safety considering the possibility of metal fatigue or other structural damage (i.e. safety is maintained by adequate structural inspection until the damage is repaired). One prerequisite for the successful application of the damage tolerance approach for managing fatigue is that crack growth and residual strength can be anticipated with sufficient precision to allow inspections to be established that will detect cracking before it reaches a size that will degrade the strength below a specified level. A damage tolerance evaluation entails the prediction of sites where fatigue cracks are most likely to initiate in the aircraft's structure, the prediction of the crack path and rates of growth under repeated aircraft structural loading, the prediction of the size of the damage at which strength limits are exceeded, and an analysis of the potential opportunities for inspection of the damage as it progresses. This information is used to establish an inspection programme for the structure that will be able to detect cracking that may develop before it precipitates a major structural failure.

The evidence to date is that when all critical structure is included, damage tolerance-based inspections and procedures, including modification and replacement, provide the best assurance of continued structural integrity that is currently available. In order to apply this concept to existing transport aeroplanes, the competent authorities issued a series of ADs requiring compliance with the first supplemental inspection programmes resulting from application of this concept to existing aeroplanes. Generally, these ADs require that operators incorporate SSIDs into their maintenance programmes for the affected aeroplanes. These documents were derived from damage tolerance assessments of the originally certified type designs for these aeroplanes. For this reason, the majority of ADs written for the SSIP did not attempt to address issues relating to damage tolerance of repairs that had been made to the aeroplanes. The objective of this programme is to provide the same level of assurance for areas of the structure that have been repaired as that achieved by the SSIP for the baseline structure as originally certified.

The fatigue and damage tolerance evaluation of a repair would be used in an assessment programme to establish an appropriate inspection programme, or a replacement schedule if the necessary inspection programme is too demanding or not possible. The objective of the repair assessment is to assure the continued structural integrity of the repaired and adjacent structure based on damage tolerance principles. Any identified supplemental inspections are intended to detect damage which may develop in a repaired area, before that damage degrades the load carrying capability of the structure below the levels required by the applicable airworthiness standards.

The following guidance is intended to help TCHs and operators establish and implement a damage tolerance-based maintenance programme for repairs affecting FCBS. Additional guidance for repairs to modified structure is provided in paragraph 4.

3.1. Overview of the TCH tasks for repairs that may affect FCBS

- (a) Identify the affected aircraft model, models, aircraft serial numbers, and DSG stated as a number of flight cycles, flight hours, or both.
- (b) Identify the certification level.
- (c) Identify and develop a list of FCBS.
- (d) Submit the list of FCBS to EASA for approval, and make it available to operators and STC holders.
- (e) Review and update published repair data as necessary.
- (f) Submit any new or updated published repair data to EASA for approval, and make it available to operators.
- (g) Develop Repair Evaluation Guidelines (REGs) and submit them to EASA for approval, and make the approved REGs available to operators.

3.2. Certification level

In order to understand what data is required, the TCH should identify the amendment level of the original aircraft certification relative to CS 25.571. The amendment level is useful in identifying what DT data may be available and what standard should be used for developing new DT data. The two relevant aircraft groups are:

Group A Aircraft certified to CAR 4b or FAR § 25.571, prior to Amendment 25-45 or JAR 25 Change 7 or equivalent. These aircraft were not evaluated for damage tolerance as part of the original type certification. Unless previously accomplished, existing and future repairs to FCBS will need DT data to be developed.

Group B Aircraft certified to JAR 25 Change 7 or FAR 25.571, Amendment 25-45 or later. These aircraft were evaluated for damage tolerance as part of the original type certification. As noted in the introduction, some of these repairs may not have repair data that includes appropriate DTI and the TCH and operators may need to identify and perform a DTE of these repairs and develop DTI.

3.3. Identifying Fatigue-Critical Baseline Structure (FCBS)

TC holders should identify and make available to operators a list of baseline structure that is susceptible to fatigue cracking and which could contribute to a catastrophic failure. The term 'baseline' refers to the structure that is designed under the original type certificate or amended type certificate for that aircraft model (that is, the 'as delivered aircraft model configuration'). Guidance for identifying this structure can be found in CS-

25 AMC 25.571. This structure is referred to in this AMC as 'fatigue-critical baseline structure.' The purpose of requiring identification and listing of fatigue-critical structure (FCS) is to provide operators with a tool that will help in evaluating existing and future repairs or modifications. In this context, FCS is any structure that is susceptible to fatigue that could contribute to a catastrophic failure, and should be subject to a damage tolerance evaluation (DTE). DTE would determine if DTIs need to be established for the repaired or modified structure. For the purpose of this AMC, structure that is modified after aircraft delivery from the TCH is not considered to be 'baseline' structure.

CS 25.571(a) states that 'An evaluation of the strength, detail design, and fabrication must show that catastrophic failure due to fatigue environmental and accidental damage, will be avoided throughout the operational life of the aeroplane. This evaluation must be conducted... for each part of the structure which could contribute to a catastrophic failure (such as wing, empennage, control surfaces, fuselage, engine mounts, and their related primary attachments)...'. When identifying FCBS, it is not sufficient to consider only that structure identified in the supplemental structural inspection document (SSID) or airworthiness limitation section (ALS). Some SSIDs or ALSs might only include supplemental inspections of the most highly stressed elements of the FCBS. An SSID and ALS often refer to this structure as a Principal Structural Element (PSE). If repaired, other areas of structure not identified as a PSE in the SSID or ALS may require supplemental inspections. The term PSE has, at times, been interpreted narrowly by industry. The narrow application of the term PSE could incorrectly limit the scope of the structure that would be considered relative to fatigue if repairs or modifications exist or are made subsequently. The relationship between PSE and FCS could vary significantly depending on the TCH's working definition of PSE. In addition, there may be structure whose failure would be catastrophic, but due to low operational loads on that part, the part will not experience fatigue cracking. However, if the subject part is repaired or modified, the stresses in that part may be increased to a level where it is now susceptible to fatigue cracking. These types of parts should be considered as FCS.

TC holders should develop the list of FCBS and include the locations of FCS and a diagram showing the extent of FCS. TC holders should make the list available to STC holders and to operators.

3.4. Certification standard applied when performing DTE

For Group A aircraft, the TC holder should use the requirements of JAR 25.571 Change 7 or § 25.571, at Amendment 25-45, as a minimum standard. For Group B aircraft, the TC holder should use the requirements that correspond to the original certification basis as a minimum standard. For each repair requiring a DTE, the DAH should apply not less than the minimum standard when developing new or revised DT data. The certification standard applied by the TC holder in performing a DTE for repairs should be included in the relevant approved documentation to the operator.

3.5. Performing DTE on a repair that affects FCBS

When performing a DTE on a repair that affects FCBS, the DTE would apply to the affected FCBS and repair. This may consist of an individual analysis or the application of a DT-based process such as RAGs that would be used by an operator. The result of the DTE should lead to developing DTI that address any adverse effects the repair may have on the FCBS. If the DTE results determine that DTIs are not required to ensure the continued airworthiness of the affected FCBS, the TC holder should note that in the DTE documentation.

The term 'adverse effects' refers to a degradation in the fatigue life or inspectability of the affected FCBS. Degradation in fatigue life (earlier occurrence of critical fatigue cracking) may result from an increase in internal loading, while degradation of

inspectability may result from physical changes made to the structure. The DTE should be performed within a time frame that ensures the continued airworthiness of affected FCBS.

3.6. Review of published repair data

Published repair data are generally applicable instructions for accomplishing repairs, such as those contained in SRMs and SBs. TCHs should review their existing repair data and identify each repair that affects FCBS. For each such repair, unless previously accomplished, the TCH must perform a DTE and develop any necessary DTI for the affected FCBS and repair data. For some repairs, the results of the DTE will conclude that no new DTI will be required for the affected FCBS or repair. For these cases, the TCH should provide a means that informs the operator a DTE was performed for the subject repair. This may be accomplished, for example, by providing a statement in a document, such as an SRM, stating that all repairs contained in this manual have had a DTE performed. This should preclude operators from questioning those repairs that do not have DTIs. TCHs should provide a list of their published repair data to operators and a statement that a DTE has been performed on this data. The following examples of published repair data developed by the TCH should be reviewed and included in this list:

- (a) SRMs,
- (b) SBs,
- (c) documents containing AD-mandated repairs, and
- (d) other documents available to operators (e.g. some sections of aircraft maintenance manuals and component maintenance manuals) that may contain approved repair data.

3.7. Developing DT data for existing published repair data

3.7.1. SRMs

The TCH should review the repair data contained in each SRM and identify repairs that affect FCBS. For these repairs, the TCH will need to determine if the SRM needs revising to provide adequate DTI. In determining the extent to which an SRM may need to be revised for compliance, the following should be considered:

- (a) Whether the existing SRM contains an adequate description of DTIs for the specific model.
- (b) Whether normal maintenance procedures (e.g. the inspection threshold and/or existing normal maintenance inspections) are adequate to ensure that the continued airworthiness (inspectability) is equal to the unrepaired surrounding structure.
- (c) Whether SRM Chapter 51 standard repairs have a DT evaluation.
- (d) Whether all SRM-specific repairs affecting FCBS have had a DTE performed.
- (e) Whether there is any guidance on proximity of repairs.
- (f) Whether existing superseded repairs are addressed and how a DTE will be performed for repairs that are likely to be superseded in the future and how any DTI will be made available.

3.7.2. SBs

The TCH should review the repair data contained in its SBs and identify those repairs that affect FCBS. For those repairs, the TCH should then determine if a new DTE will need to

be performed. This review may be done in conjunction with the review of SBs for modifications that affect FCBS.

3.7.3. ADs

The TCH should review ADs that provide maintenance instructions to repair FCBS and determine if the instructions include any necessary DT data. While maintenance instructions supporting ADs are typically contained in SBs, other means of documentation may be used.

3.7.4. Other forms of data transmission

In addition to SRMs, SBs, and documentation for ADs, the TCH should review any other documents (e.g. aircraft maintenance manuals and component maintenance manuals) that contain approved repair data. Individual repair data not contained in the above documents will be identified and DT data obtained through the Repair Evaluation Guidelines process.

3.8. Developing DT data for future published repair data

Following the completion of the review and revision of existing published data any subsequent repair data proposed for publication should also be subject to DTE and DTI provided.

3.9. Approval of DT data developed for published repair data

For existing published repair data that requires new DT data for repairs affecting FCBS, the TCH should submit the revised documentation to EASA for approval unless otherwise agreed. The DT data for future published repair data may be approved according to existing processes.

3.10. Documentation of DT data developed for published repair data

TCH should include the means used to document any new DTI developed for published repair data. For example, in lieu of revising individual SBs, the TCH may choose to establish a collector document that would contain new DTI developed and approved for specific repairs contained in various SBs.

3.11. Existing repairs

TCHs should develop processes that will enable operators to identify and obtain DTI for existing repairs on their aircraft that affect FCBS. Collectively, these processes are referred to as REGs and are addressed below.

3.12. Future repairs

Repairs to FCS conducted after the operator has incorporated the REGs into their maintenance programme must have a DTE performed. This includes blend-outs, trim-outs, etc., that are beyond published limits. For new repairs, the applicant may, in conjunction with an operator, use the three-stage approval process provided in Annex 1 to this Appendix. This process involves incremental approval of certain engineering data to allow an operator to return its aircraft to service before all DT data are developed and approved. The applicant should document this process for the operator's reference in their maintenance programme if it intends to apply it.

3.13. Repair evaluation guidelines

REGs provide instructions to the operator on how to survey aircraft, how to obtain DTI, and an implementation schedule that provides timelines for these actions. An effective REG may require that certain DT data be developed by the TCH and made available to operators. Updated SRMs and SBs, together with the existing, expanded, or new RAG documents, form the core of the information that will need to be made available to the operator to support this process. In developing REGs the TCH will need to determine what DT data are currently available for repairs and what new DT data will need to be developed to support operator compliance. The REGs should include:

- (a) a process for conducting surveys of affected aircraft that will enable identification and documentation of all existing repairs that affect fatigue-critical baseline structure;
- (b) a process for obtaining DTI for repairs affecting FCBS that are identified during an aircraft survey; and
- (c) an implementation schedule that provides timelines for:
 - (1) conducting aircraft surveys,
 - (2) obtaining DTI, and
 - (3) incorporating DTI into the operator's maintenance programme.

3.13.1. Implementation schedule

- (a) The schedule provided in this section is applicable to REGs produced in compliance with Part 26.320. In cases where a REG is deemed necessary, the TCH should propose a schedule for approval by EASA based on the guidance given in paragraph 12 of the main body of this AMC that takes into account the distribution of the fleet relative to $\frac{3}{4}$ DSG, the extent of the work involved, and the airworthiness risk. The Agency notes that many fleets are currently approaching or exceeding DSG and this should be given priority in the implementation schedule.

- (b) Survey schedule for EASA-approved REGs applicable to aircraft maintained under Part-M.

The following basis for accomplishing the aircraft repair assessment survey is approved by EASA and may be used by operators maintaining aircraft according to Part-M and Part-26 requirements:

The repair survey, the first step of the repair assessment, must be carried out at the earliest convenient opportunity (e.g. next heavy maintenance check) without exceeding the DSG or a period of seven years following the approval by EASA of this REG, whichever occurs later.

To ensure the TCH can support the operators' requests for data following the survey, operators should not defer the implementation of the programme across their fleet until the end of the allowed time period.

- (c) Obtaining DTI and incorporation of the Damage Tolerance Inspection (DTI) into the maintenance program must be completed as follows:

For existing, non-published repairs and deviations to published repairs identified in the survey, if REGs direct operators to contact the TC holder to obtain DTIs, the TC holder should approve the DTI within 12 months after identification, unless the TCH uses another process agreed by EASA. To facilitate this, the operator should

provide the TC holder with that request and associated information within 3 months from the identification.

For repairs covered by TC holder published repair data, operators should obtain and incorporate into their maintenance program DTIs for existing repairs within 6 months after accomplishing the aeroplane survey. For non-published repairs found during the survey, incorporation should be completed no later than 6 months after approval of the data (see Annex 2 of this AMC for the DTI assessment process).

3.13.2. Developing a process for conducting surveys on affected aircraft

The TCH should develop a process to be used by operators to conduct aircraft surveys. These aircraft surveys are conducted by operators to identify and document repairs and repairs to modifications that may be installed on their aircraft. The survey is intended to help the operators determine which repairs may need a DTE in order to establish the need for DTI. Identification of repairs that need DTI should encompass only existing repairs that reinforce (e.g. restore strength) the FCBS. This typically excludes maintenance actions such as blend-outs, plug rivets, trim-outs, etc., unless there are known specific risks associated with these actions in specific locations. The process the TCH develops to conduct surveys should include:

- (a) a survey schedule;
- (b) areas and access provisions for the survey;
- (c) a procedure for repair data collection that includes:
 - (1) repair dimensions,
 - (2) repair material,
 - (3) repair fastener type,
 - (4) repair location,
 - (5) repair proximity to other repairs,
 - (6) repairs covered by published repair data, and
 - (7) repairs requiring DTI;
- (d) a means to determine whether a repair affects FCBS or not.

3.13.3. Developing a process to obtain DT data for repairs

- (a) The TCH must develop a process that operators can use to obtain DTIs that address the adverse effects repairs may have on FCBS. In developing this process, TCHs will need to identify all applicable DTIs they have developed that are available to operators. This may include updated SRMs and SBs, existing RAGs, expanded or new RAGs, and other sources of DTIs developed by the TCH. For certain repairs, the process may instruct the operators to obtain direct support from the TCH. In this case, the TCH evaluates the operator's request and makes available DTI for a specific repair or group of repairs, as needed. These may include operator or third-party developed/approved repairs, and repairs that deviate from approved published repair data.
- (b) The process should state that existing repairs that already have DTIs developed and in place in the maintenance programme require no further action. For existing repairs identified during an individual aircraft survey that need DTIs established, the process may direct the operators to obtain the required DTIs from the following sources:

- (1) TCH published service information such as DT-based SRMs, SBs, or other documents containing applicable DT data for repairs.
- (2) Existing approved RAG documents (developed for compliance with SFAR § 121.107).
- (3) Expanded or newly developed RAG documents. In order to expedite the process for an operator to obtain the necessary DTI to address the adverse effects repairs may have on FCBS, the TCH may determine that the existing RAG document should be expanded to address other FCBS of the aircraft's pressure limits. In addition, for aircraft that do not currently have a RAG, the TCH may determine that in order to fully support operators in obtaining DTI, a new RAG document may need to be developed. General guidance for developing this material can be found in Annex 2 below, which is similar to FAA AC 120-73, *Damage Tolerance Assessment of Repairs to Pressurised Fuselages*.
- (4) Procedures developed to enable operators to establish DTIs without having to contact the TCH for direct support. These procedures may be similar in concept to the RAG documents.
- (5) Direct support from the TCH for certain repairs. The operator directly solicits DTIs from a TCH for certain individual repairs as those repairs are identified during the survey.

3.14. Repairs to removable structural components

Fatigue-critical structure may include structure on removable structural parts or assemblies that can be exchanged from one aircraft to another, such as door assemblies and flight control surfaces. In principle, the DT data development and implementation process also applies to repairs to FCS on removable components. During their life history, however, these parts may not have had their flight times recorded on an individual component level because they have been removed and reinstalled on different aircraft multiple times. These actions may make it impossible to determine the component's age or total flight hours or total flight cycles. In these situations, guidance for developing and implementing DT data for existing and new repairs is provided in Annex 3 to this Appendix.

3.15. Training

The complexity of the repair assessment and evaluation may require adequate training for proper implementation. In that case, it is necessary that each TCH consider providing training to all operators of the aircraft considered in this AMC.

4. MODIFICATIONS AND REPAIRS TO MODIFICATIONS

4.1. TCH and STC holder tasks – Modifications and repairs to modifications

The following is an overview of the TCH and STC holder tasks necessary for modifications that affect FCBS. This overview also includes TCH and STC holder tasks necessary for repairs that may affect any FCS of the subject modifications. These tasks are applicable to those modifications that have been developed by the TCH or STC holder.

- (a) Establish a list of modifications that may affect FCBS. From that list establish a list of modifications that may contain FCS.
- (b) In consultation with operators, determine which aircraft have the modification(s) installed.
- (c) STC holders should obtain a list of FCBS from the TCH for the aircraft models identified above.
- (d) STC holders should identify:
 - modifications that affect FCBS, or
 - modifications that contain FCS.
- (e) Determine if DT data exist for the identified modifications.
- (f) Develop additional DT data, if necessary.
- (g) Establish an implementation schedule for modifications.
- (h) Review existing DT data for published repairs made to modifications that affect FCBS.
- (i) Develop additional DT data for published repairs made to modifications that affect FCBS.
- (j) Establish an implementation schedule for published repairs made to modifications.
- (k) Prepare documentation, submit it to EASA for approval, and make it available to operators.

4.2. Specific modifications to be considered

The TCH should consider modifications and any STCs they own for modifications that fall into any of the categories listed in Annex 5 to this Appendix. STC holders should do the same for their STC modifications. For modifications that are not developed by a TCH or STC holder, the operator should consider whether the modification falls into any of the categories listed in Annex 5 to this Appendix.

4.3. Modifications that need DT data

Using the guidance provided in AMC 25.571 and the detailed knowledge of the modification and its effect on the FCBS, the TCH and STC holder, and in certain cases the operator, should consider the following situations in determining what DT data need to be developed.

4.3.1. Modifications that affect FCBS

Any modification identified in Annex 5 that is installed on FCBS should be evaluated regardless of the size or complexity of the modification. In addition, any modification which indirectly affects FCBS (e.g. modifications which change the fatigue loads environment, or affect the inspectability of the structure, etc.) must also have a DT evaluation performed to assess its impact.

4.3.2. Modifications that contain new FCS

For any modification identified in Annex 5 to this Appendix that affects FCBS, the TCH or STC holder should identify any FCS of the modification. Any modification that contains new FCS should be evaluated regardless of the size or complexity of the modification. Examples of this type of modification may be a modification that adds new structural splices, or increases the operational loads causing existing structure to become fatigue critical. If a modification does not affect FCBS, then it can be assumed that this modification does not contain FCS.

4.4. Reviewing existing DT data for modifications that affect FCBS

Based on the CS 25.571 certification amendment level and other existing rules, the modification's approval documentation may already provide appropriate DT data.

The TCH or STC holder should identify modifications that have existing approved DT data. Acceptable DT data contain a statement of DTE accomplishment and are approved. Confirmation that approved DT data exists should be provided to the operators.

Modifications that have been developed by a TCH may affect FCBS. These include ATCs design changes and in some cases STCs. These changes to type design also require review for appropriate DT data.

4.5. Developing additional DT data for modifications that affect FCBS

DT data may be submitted for approval and published as follows:

- (a) **STC modifications:** Additional DT data for existing modifications may be approved as a change to the existing STC by the STCH and published in the form of amended STC, a supplemental compliance document, or an individual approval for example as a supplement to the ALS.
- (b) **TC holder modifications:** The Additional DT data for existing modifications may be published in the form of an amended TC, a revised ALS, SSID and TCH service information, etc.
- (c) **Modifications not developed by a TCH or STC holder:** For modifications identified in Annex 5 to this Appendix that affect FCBS and were not developed by a TCH or STC holder, the operator is responsible for obtaining DT data for those modifications. For those existing individual modifications that do not have DT data or other procedures implemented, establish DT data according to an implementation plan approved by the competent authority. The approval of such data will be under a new STC.

Note: The TCH and STC holder should submit data that describes and supports the means used to determine if a modification affects FCBS, and the means used for establishing FCS of a modification.

4.6. DT data implementation schedule when the TCH or STC holder is no longer in business or a TC or STC is surrendered

For those modifications where the TCH or STC holder is no longer in business or the TC or STC is surrendered, this paragraph provides guidance for an operator to produce a DT data implementation schedule for that modification. The operator's DT data implementation schedule should contain the following information:

- (a) a description of the modification;
- (b) the affected aircraft and the affected FCS;
- (c) the DSG of the affected aircraft;
- (d) a list of the modification FCS (if it exists);
- (e) the 25.571 certification level for determining DT data;
- (f) a plan for obtaining DT data for the modification (e.g. former contract with a Part-21 Subpart J approved third party to produce DT data within a specified compliance time; and
- (g) a DT data implementation schedule for incorporating DT data once they are received.

Note: An alternative may be to remove the modification and return the structure to its original certified condition.

5. DEVELOPMENT OF TCH AND STC HOLDER DOCUMENTATION AND EASA APPROVAL

TCH, STC holders, operators and airworthiness authorities should work together to develop model-specific documentation with oversight provided by those authorities and assistance from the ARAC AAWG. It is anticipated that TCHs will utilise structural task groups (STGs) to support their development of model-specific documents. EASA will approve the TCH or STC holder submissions of the REGs and any other associated documentation required by the operator to provide appropriate DTI to all repairs and modifications to FCS whether submitted as separate documents or in a consolidated one.

6. OPERATOR TASKS — REPAIRS, MODIFICATIONS AND REPAIRS TO MODIFICATIONS

- (a) Review the applicable documents supplied by TCH and STC holders.
- (b) Identify modifications that exist in the operators' fleet that affect FCBS.
- (c) Obtain or develop additional DT data for modifications not addressed by the TCH or STC holder's documents.

Note: If the TCH or STC holder no longer exists or is unwilling to comply with this request, it becomes the responsibility of the operator to develop or obtain approved DT data. The data should be provided by a design organisation with an appropriate DOA.

- (d) Incorporate the necessary actions into the maintenance programme for approval by the competent authority.

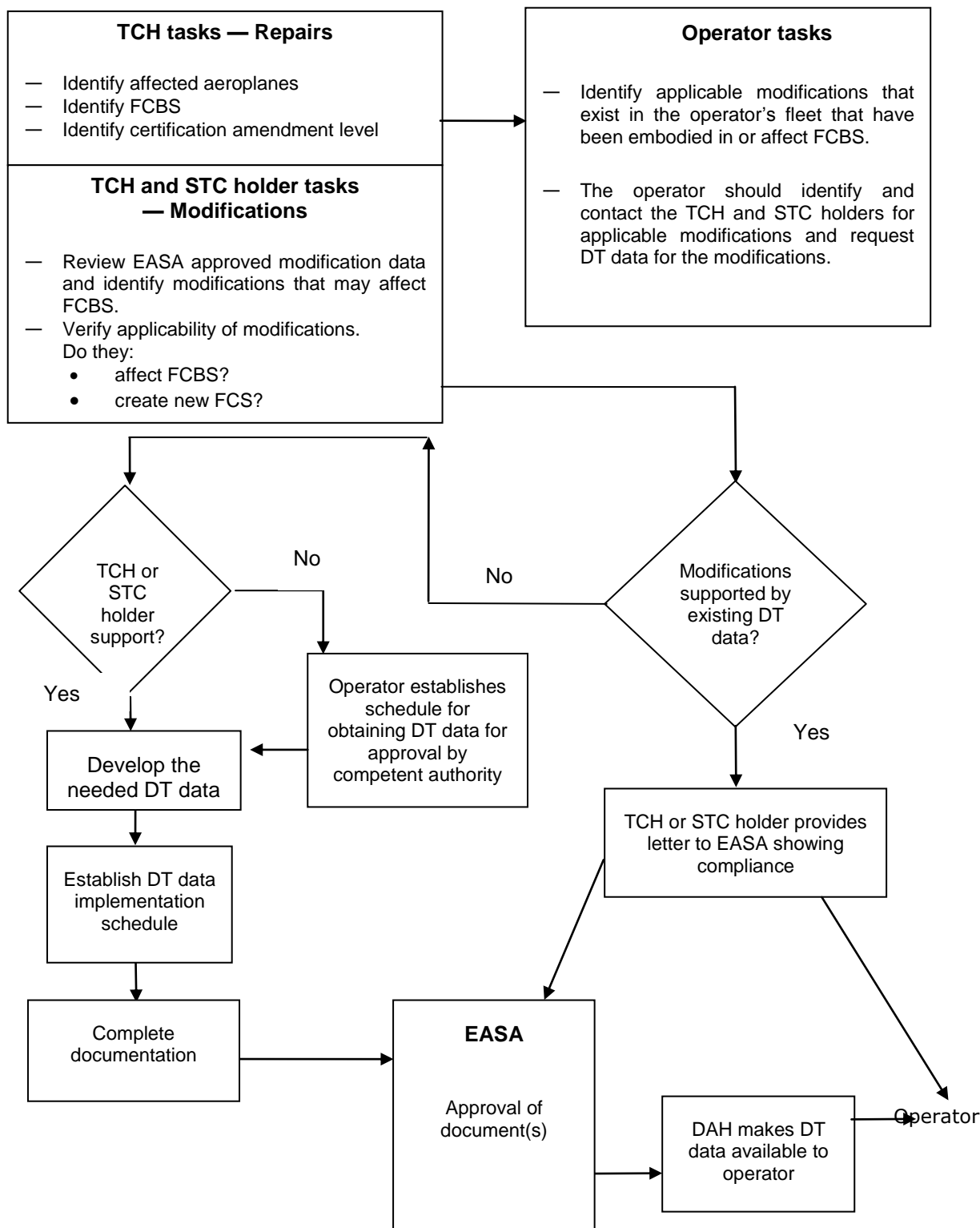

Figure A3-1: Developing a means of compliance for modifications

6.1. Contents of the maintenance programme

- (a) The operator should include the following in their maintenance programme:
- (1) A process to ensure that all new repairs and modifications that affect FCBS will have DT data and DTI or other procedures implemented.
 - (2) A process to ensure that all existing repairs and modifications to FCBS are evaluated for damage tolerance and have DTI or other procedures implemented. This process includes:
 - (i) a review of the operator processes to determine if DT data for repairs and modifications affecting FCBS have been developed and incorporated into the operator's maintenance programme for the operational life of the aircraft. If an operator is able to demonstrate that these processes ensure that DT data are developed for all repairs and modifications affecting FCBS, then no further action is required for existing repairs and modifications;
 - (ii) a process to identify or survey existing repairs (using the survey parameters from Annex 3 to this Appendix) and modifications that affect FCBS and determine DTI for those repairs and modifications. This should include an implementation schedule that provides timing for incorporation of DT data into the operator's maintenance programme, within the time frame given in the applicable TCH or STC holder's approved documentation.
- (b) Figure A3-2 below outlines one possible means an operator can use to develop an implementation plan for aircraft in their fleet.

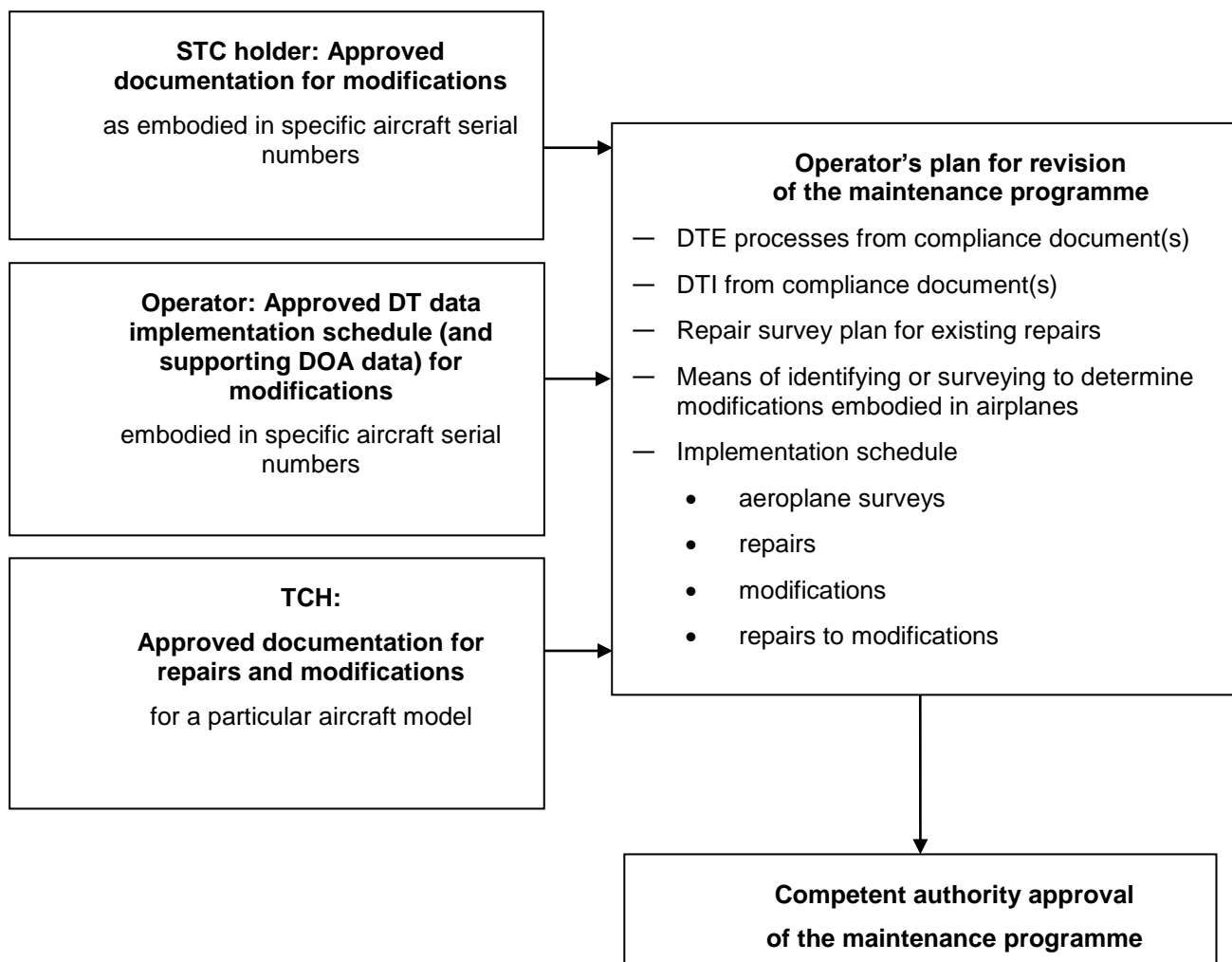

Figure A3-2: Operator's maintenance programme approval process

6.1.1. Implementation plan for repairs

Repair survey plan. The maintenance programme should include a repair survey schedule to identify repairs that may need DT data developed. The TCH's REG may be used as a basis for this plan. (See paragraph 3.13 above and Annex 2 for further information)

6.1.2. Implementation plan for modifications

- (a) The plan should include a process for producing a list of modifications that affect FCBS on an operator's aircraft. The list ~~may~~ should first be developed by obtaining data through a review of the aircraft records ~~and by a survey of the aircraft. If the means for identifying the subject modifications is by records review,~~ The operator will need to show to their competent authority that the aircraft records are a reliable means for identifying modifications that affect FCBS. As per guidance in paragraph (3)(c) below, the operator may identify modifications developed by TCH and STC holders by performing a records review. ~~A records review, however, may not be adequate to identify modifications not developed by a TCH or STC Holder. Under Part-M requirements the aircraft records should be sufficient to help identify whether DTI exists for all modifications (Ref. M.A.305(d) and AMC M.A.305(d)). However, for some older aircraft a records review may not always be adequate to identify all modifications that have an adverse effect on FCBS. An aircraft survey may need to be conducted to identify such modifications, which could be done at the time of the repair survey.~~ For each modification that affects FCBS, the process should document the means of compliance for incorporating DT data associated with that modification, whether through a TCH or STC holder compliance document, an operator's DT data implementation schedule, or existing DT-based ICA.
- (b) The plan should:
- (1) include the process for when and how to obtain DT data for those modifications included in a DT data implementation schedule;
 - (2) include a means of ensuring that the aircraft will not be operated beyond the time limit established for obtaining DT data;
 - (3) include DT data associated with a modification that is provided in a compliance document; and
 - (4) identify how DT data will be incorporated into the operator's maintenance programme.
- (c) To support identification of modifications that TCH and STC holders need to address, the operators should — concurrent with the TC and STC holders' tasks — identify the TCH or STC holder-developed modifications that exist in their aircraft fleet. This may be done by reviewing the operator's aircraft configuration records, if record keeping is complete. During the review, the TCH and STC holder of each specific modification should be identified. The operator should then establish which modifications have been installed on or are likely to affect FCBS and prepare a list of modifications by aircraft. Modifications not developed by a TCH or STC holder that affect FCBS should be identified at the time the operator conducts their aircraft survey for repairs.
- (1) Compile a listing of all TCH and STC holder-developed modifications that are currently installed on their active fleet.
 - (2) Delete from the listing those modifications that do not affect FCBS. Documents from the TCH may be used to identify FCBS.
 - (3) The remaining modifications that affect FCBS on this list require DTE and DT data, unless previously accomplished.

- (4) The operator must review each modification to determine whether:
 - (i) DT data already exist; or
 - (ii) DT data need to be developed.
- (5) Notify the STC holder, the competent authority and EASA when STCs owned by the STC holder are identified in the operator's fleet and that DT data are required.

Note: The operator should ideally begin developing this modifications list as soon as the TCHs make their FCBS listing available.

- (d) The operator should consider the list of modifications contained in Annex 5 to this AMC in determining which modifications may affect FCBS on a model-specific basis.
- (e) The operator should submit a letter that provides a list of modifications they have on their active fleet to the competent authority and a status of the TCH or STC holders' support for developing required DT data.
- (f) The operator should also contact the TCH or STC holder for the applicable modification to determine if DT data are available for that modification. If data do not exist, and the TCH or STC holder intends to support the development of DT data, and this modification is likely to exist on other operators' fleets, the group of affected operators may wish to collectively meet with the TCH or STC holder. If the TCH or STC holder no longer exists, or is unwilling to support the modification, or if a modification affecting FCBS has not been approved under a TC or STC, it is the responsibility of the operator(s) to acquire the data, with the appropriate design approval.
- (g) Some individual modifications may not be easily identified through a review of the aircraft maintenance records. In these situations, the means of compliance is a plan to survey the aircraft for modifications in the similar manner as repairs and repairs to modifications as given in paragraph 3 of this Appendix. DT data for those modifications identified in the survey should be developed and implemented into an operator's maintenance programme. It is anticipated that most aircraft will need to be surveyed in order to ensure that all modifications are identified. This survey can be conducted at the same time the survey for repairs is performed.

6.1.3. DT data implementation process

- (a) Use the regular maintenance or inspection programme for repairs where the inspection requirements utilise the chosen inspection method and interval. Repairs or modifications added between the predetermined maintenance visits, including Category B and C repairs (see Annex 2 to this Appendix) installed at remote locations, should have a threshold greater than the predetermined maintenance visit. Repairs may also be individually tracked to account for their unique inspection method and interval requirements. This ensures the airworthiness of the structure until the next predetermined maintenance visit, when the repair or modification will be evaluated as part of the repair maintenance programme.
- (b) Where inspection requirements are not fulfilled by the chosen inspection method and interval, Category B or C repairs will need additional attention. These repairs will either require upgrading to allow utilising the chosen inspection method and interval, or individual tracking to account for the repair's unique inspection method and interval requirements.

6.2. Maintenance programme changes

When a maintenance or inspection programme interval is revised, the operator should evaluate the impact of the change on the repair assessment programme. If the revised

maintenance or inspection programme intervals are greater than those in the BZI, the previous classification of Category A repairs may become invalid. The operator may need to obtain approval of an alternative inspection method, upgrade the repair to allow utilisation of the chosen inspection method and interval, or recategorise some repairs and establish unique supplemental inspection methods and intervals for specific repairs. Operators using the 'second technique' of conducting repetitive repair assessments at predetermined maintenance visits would evaluate whether the change to the predetermined maintenance visit continues to fulfil the repair inspection requirements in accordance with the guidance provided in Annex 2 to this AMC.

6.3. Schedule for identifying modifications, ensuring that approved DTI exists or is developed and approved and implementing DTI

Part 26.320 and 26.330 require DAHs to develop DTI for modifications (design changes) within a certain timescale. Part 26.370 requires operators to revise the maintenance programme to show how approved DTI data will be obtained and used to address the potential adverse effects of repairs and modifications to fatigue-critical structure and submit it for approval to the competent authority. The maintenance programme should reflect the requirements of Part 26.320 and 26.330 for DTI for design changes and modifications, allowing a maximum of 12 months for incorporation of the DTI provided directly by the DAH into the maintenance programme.

Operators should accomplish the first inspection of an change according to the DTI schedule. If the age of the modification is unknown, use the aircraft age in total flight cycles or total flight hours, as applicable.

For aircraft which have not reached the inspection threshold for a DTI, accomplish the first inspection of the modification before the inspection threshold. If this is not practical or the aircraft has already exceed the threshold, acquire revised instructions and support from the DAH to vary the threshold. In any case the inspection should be accomplished no later than the time limit equivalent to a C-check interval, from incorporation of the DTI into the operator's approved maintenance programme.

For modifications not identified until the time of the aircraft survey (6.1.2 (a)) or modifications for which DTI has not been provided by the DAH, acquire the data according to the schedule based on the guidance provided in Section 4.6 of this Appendix.

7. ROLE OF THE COMPETENT AUTHORITY

The competent authority is responsible for ~~approving the means for incorporating the Agency Approved DT data for repairs and modifications into the operator's maintenance programme~~ ensuring that the TCH's REG and Agency-approved DT data for repairs and modifications are incorporated into the operator's approved maintenance programme. Furthermore, for aircraft affected by Part 26.370(a)(5) the competent authority should ensure that the programme is revised to address the adverse effects of all modifications to FCS or including FCS.

ANNEX 1

APPROVAL PROCESS FOR NEW REPAIRS

In the past, FAA AC 25.1529-1 *Instructions for Continued Airworthiness of Structural Repairs on Transport Aircraft*, August 1, 1991, described a two-stage approach for approving repairs to principal structural elements. The two-stage approach consisted of:

- evaluating type design strength requirements per CS 25.305 before return to service; and
- performing a damage tolerance evaluation and developing DT data to demonstrate compliance with CS 25.571 within 12 months from return to service.

~~The FAA guidance material in AC 25.1529-1 is now embodied in this AMC, and is modified to describe a three-stage approach now commonly used in the aviation industry. The three-stage approach is in lieu of the two-stage approach discussed above.~~

The approval process for new repairs may be modified to a three-stage approach as now commonly used in the aviation industry and also described in FAA AC 120-93.

DT data include inspection requirements, such as inspection threshold, inspection method, and inspection repetitive interval, or may specify a time limit when a repair or modification needs to be replaced or modified. The required data may be submitted all at once, prior to the aircraft's return to service, or it may be submitted in stages. The following three-stage approval process is available, which involves incremental approval of engineering data to allow an aircraft to return to service before all the engineering data previously described are submitted. The three stages are described as follows:

- (a) The first stage is approval of the static strength data and the schedule for submission of DT data. This approval is required prior to returning an aircraft to service.
- (b) The second stage is approval of DT data. Sufficient data to substantiate continued safe operation This should be submitted not later than 12 months after the aircraft was returned to service, unless a temporary limitation was substantiated by sufficient fatigue and damage tolerance evaluation data and approved at the first stage of approval, in which case the second stage DT data should be approved before the temporary limit is reached. At the this-second stage, the DT data need only contain the threshold when inspections are required to begin as long as a process is in place to develop the required inspection method and repetitive intervals before the threshold is reached. In this case, the submission and approval of the remaining DT data may be deferred to the third stage. The approved threshold acts as a limitation of the repair data.
- (c) The third stage is approval of the inspection method and the repetitive intervals. This final element of the repair certification data in compliance with CS 25.571 must be submitted and approved prior to the inspection threshold being reached.

The applicant should inform the operator if this process is being used and the expected timelines for the data delivery.

ANNEX 2

ASSESSMENT OF EXISTING REPAIRS

A DTI assessment process consists of an aircraft repair survey, identification and disposition of repairs requiring immediate action and development of damage tolerance-based inspections, as described below.

1. AIRCRAFT REPAIR SURVEY

A survey will be used to identify existing repairs and repair configurations on all FCBS and provide a means to categorise those repairs. The survey would apply to all affected aircraft in an operator's fleet, as defined in the maintenance programme, using the process contained in the REG or similar document. The procedure to identify repairs that require DTE should be developed and documented using CS 25.571 and AMC 25.571 (dependent on aircraft certification level), together with additional guidance specific to repairs, such as:

- (a) Size of the repair;
- (b) Repair configuration:
 - (1) SRM standards,
 - (2) other;
- (c) Proximity to other repairs; and
- (d) Potential effect on FCS:
 - (1) inspectability (access and method),
 - (2) load distribution.

See Paragraph 4 of this Annex for more details.

2. IDENTIFICATION AND DISPOSITION OF REPAIRS REQUIRING IMMEDIATE ACTION

Certain repairs may not meet the minimum requirements because of cracking, corrosion, dents, or inadequate design. The operator should use the guidance provided in the compliance document to identify these repairs and, once identified, take appropriate corrective action. In some cases, modifications may need to be made before further flight. The operator should consider establishing a fleet campaign if similar repairs may have been installed on other aircraft.

3. DAMAGE TOLERANCE INSPECTION DEVELOPMENT

This includes the development of the appropriate maintenance plan for the repair under consideration. During this step determine the inspection method, threshold, and repeat interval. Determine this information from existing guidance information as documented in the RAG (see Paragraph 4), or from the results of an individual damage tolerance evaluation performed using the guidance in AMC 25.571. Then determine the feasibility of an inspection programme to maintain continued airworthiness. If the inspection programme is practical, incorporate the DTI into the individual aircraft maintenance programme. If the inspection is either impractical or impossible, incorporate a replacement time for the repair into the individual aircraft maintenance programme. The three-stage approach discussed in Annex 1 to this AMC may be used, if appropriate.

4. REPAIR ASSESSMENT GUIDELINES

4.1. Criteria to assist in developing the repair assessment guidelines

The following criteria are those developed for the fuselage pressure boundary, similar to those found in FAA AC 120-73 and previous JAA and EASA documentation. DAHs may find it appropriate to develop similar practice for other types of aircraft and areas of the structure.

The purpose is to develop repair assessment guidelines requiring specific maintenance programmes, if necessary, to maintain the damage tolerance integrity of the repaired airframe. The following criteria have been developed to assist in the development of that guidance material:

- (a) Specific repair size limits for which no assessment is necessary may be selected for each model of aircraft and structural location. This will enable to minimise the burden on the operator while ensuring that the aircraft's baseline inspection programme remains valid.
- (b) Repairs that are not in accordance with SRM must be reviewed and may require further action.
- (c) Repairs must be reviewed where the repair has been installed in accordance with SRM data that have been superseded or rendered inactive by new damage-tolerant designs.
- (d) Repairs in close proximity to other repairs or modifications require review to determine their impact on the continued airworthiness of the aircraft.
- (e) Repairs that exhibit structural distress should be replaced before further flight.

4.2. Repair assessment methodology

The next step is to develop a repair assessment methodology that is effective in evaluating the continued airworthiness of existing repairs for the fuselage pressure boundary. Older aircraft models may have many structural repairs, so the efficiency of the assessment procedure is an important consideration. In the past, evaluation of repairs for damage tolerance would require direct assistance from the DAH. Considering that each repair design is different, that each aircraft model is different, that each area of the aircraft is subjected to a different loading environment, and that the number of engineers qualified to perform damage tolerance assessment is small, the size of an assessment task conducted in that way would be unmanageable. Therefore, a new approach has been developed as an alternative.

Since repair assessment results will depend on the model-specific structure and loading environment, the DAHs should create an assessment methodology for the types of repairs expected to be found on each affected aircraft model. Since the records of most of these repairs are not readily available, locating the repairs will necessitate surveying the structure of each aircraft. A survey form is created by the DAH that may be used to record key repair design features needed to accomplish a repair assessment. Airline personnel not trained as damage tolerance specialists can use this form to document the configuration of each observed repair.

Some DAHs have developed simplified methods using the information from the survey form as input data to determine the damage tolerance characteristics of the surveyed repairs. Although the repair assessments should be performed by well trained personnel familiar with the model-specific repair assessment guidelines, these methods enable appropriate staff, not trained as damage tolerance specialists, to perform the repair assessment without the assistance of the TCH. This methodology should be generated by

the aircraft TCH. Model-specific repair assessment guidelines will be prepared by the TCHs.

From the information on the survey form, it is also possible to classify repairs into one of three categories:

Category A: A permanent repair for which the baseline zonal inspection (BZI) (typical maintenance inspection intervals assumed to be performed by most operators) is adequate to ensure continued airworthiness.

Category B: A permanent repair that requires supplemental inspections to ensure continued airworthiness.

Category C: A temporary repair that will need to be reworked or replaced prior to an established time limit. Supplemental inspections may be necessary to ensure continued airworthiness prior to this limit.

When the LoV of the maintenance programme is extended the initial categorisation of repairs may need review by the TCH applicant for the LoV extension and the operator to ensure these remain valid up to the new LoV.

4.3. Repair assessment process

There are two principal techniques that can be used to accomplish the repair assessment. The first technique involves a three-stage procedure. This technique could be well suited for operators of small fleets. The second technique involves the incorporation of the repair assessment guidelines as part of an operator's routine maintenance programme. This approach could be well suited for operators of large fleets and would evaluate repairs at predetermined planned maintenance visits as part of the maintenance programme. DAHs and operators may develop other techniques, which would be acceptable as long as they fulfil the objectives of this proposed rule, and are approved by the Agency.

The first technique generally involves the execution of the following three stages (see Figure A3(2)-1):

Stage 1: Data collection

This stage specifies what structure should be assessed for repairs and collects data for further analysis. If a repair is on a structure in an area of concern, the analysis continues, otherwise the repair does not require classification per this programme.

Repair assessment guidelines for each model will provide a list of structure for which repair assessments are required. Some DAHs have reduced this list by determining the inspection requirements for critical details. If the requirements are equal to normal maintenance checks (e.g. BZI checks), those details maybe excluded from this list.

Repair details are collected for further analysis in Stage 2. Repairs that do not meet the minimum design requirements or are significantly degraded are immediately identified, and corrective actions must be taken before further flight.

Stage 2: Repair categorisation

Repair categorisation is accomplished by using the data gathered in Stage 1 to answer simple questions regarding structural characteristics.

If the maintenance programme is at least as rigorous as the BZI identified in the TCH's model-specific repair assessment guidelines, well designed repairs in good condition meeting size and proximity requirements are Category A. Simple condition and design criteria questions are provided in Stage 2 to define the lower bounds of Category B and C repairs. The process continues for Category B and C repairs.

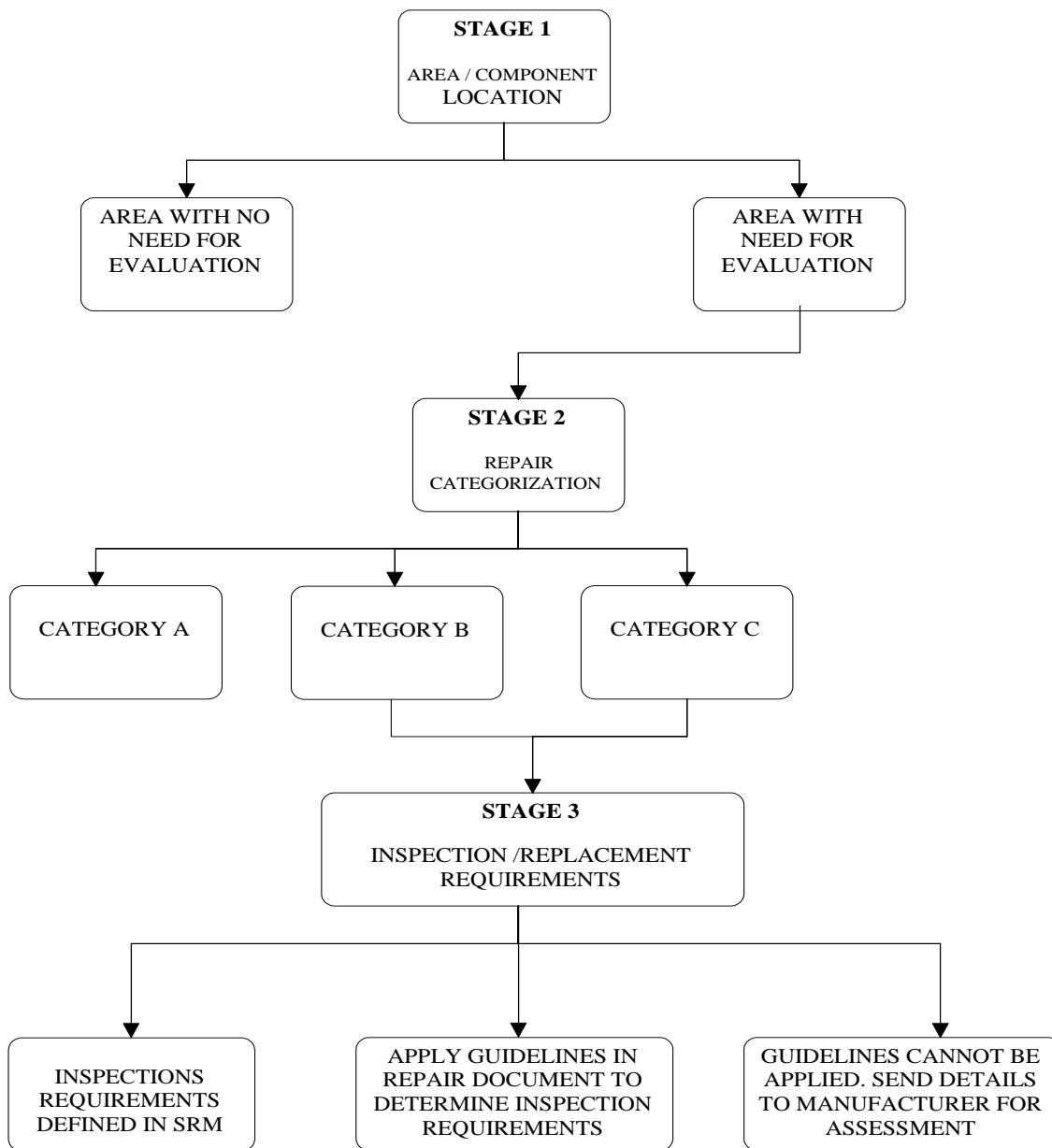

Figure A3(2)-1: Repair assessment stages

Stage 3: Determination of structural maintenance requirements

The specific supplemental inspection and/or replacement requirements for Category B and C repairs are determined in this stage. Inspection requirements for the repair are determined by calculation or by using predetermined values provided by the DAH, or other values obtained using an Agency-approved method.

In evaluating the first supplemental inspection, Stage 3 will define the inspection threshold in flight cycles measured from the time of the repair installation. If the time of the repair installation is unknown and the aircraft has exceeded the assessment implementation times or has exceeded the time for first inspection, the first inspection should occur by the next 'C-check' interval, or equivalent cycle limit after the repair data is gathered (Stage 1).

The operator may choose to accomplish all three stages at once, or just Stage 1. In the latter case, the operator would be required to adhere to the schedule specified in the Agency-approved model-specific repair assessment guidelines for completion of Stages 2 and 3. Incorporating the maintenance requirements for Category B and C repairs into an operator's individual aircraft maintenance or inspection programme completes the repair assessment process for the first technique.

The second technique would involve setting up a repair maintenance programme to evaluate all applicable structure as detailed in paragraph 2.61 at each predetermined maintenance visit to confirm that they are permanent. This technique would require the operator to choose an inspection method and interval in accordance with the Agency-approved repair assessment guidelines. The repairs whose inspection requirements are fulfilled by the chosen inspection method and interval would be inspected in accordance with the approved maintenance programme. Any repair that is not permanent, or whose inspection requirements are not fulfilled by the chosen inspection method and interval, would either be:

- (a) upgraded to allow utilisation of the chosen inspection method and interval; or
- (b) individually tracked to account for the repair's unique inspection method and interval requirements.

This process is then repeated at the chosen inspection interval.

Repairs added between the predetermined maintenance visits, including interim repairs installed at remote locations, would be required either to have a threshold greater than the length of the predetermined maintenance visit or to be tracked individually to account for the repair's unique inspection method and interval requirements. This would ensure the airworthiness of the structure until the next predetermined maintenance visit, at which time the repair would be evaluated as part of the repair maintenance programme.

5. MAINTENANCE PROGRAMME CHANGES

When a maintenance or inspection programme interval is revised, the operator should evaluate the impact of the change on the repair assessment programme. If the revised maintenance or inspection programme intervals are greater than those in the BZI, the previous classification of Category A repairs may become invalid. The operator may need to obtain approval of an alternative inspection method, upgrade the repair to allow utilisation of the chosen inspection method and interval, or recategorise some repairs and establish unique supplemental inspection methods and intervals for specific repairs. Operators using the 'second technique' of conducting repetitive repair assessments at

predetermined maintenance visits would evaluate whether the change to the predetermined maintenance visit continues to fulfil the repair inspection requirements.

6. SRM UPDATE

The general section of each SRM will contain brief descriptions of damage tolerance considerations, categories of repairs, description of BZIs, and the repair assessment logic diagram. In updating each SRM, existing location-specific repairs should be labelled with appropriate repair category identification (A, B or C), and specific inspection requirements for B and C repairs should also be provided as applicable. SRM descriptions of generic repairs will also contain repair category considerations regarding size, zone and proximity. Detailed information for the determination of inspection requirements will have to be provided for each model. Repairs which were installed in accordance with a previous revision of the SRM, but which have now been superseded by a new damage-tolerant design, will require review. Such repairs may be reclassified to Category B or C, requiring additional inspections and/or rework.

7. STRUCTURE MODIFIED BY AN STC

The current repair assessment guidelines provided by the TCH ~~do not generally apply to structure modified by an STC.~~ are not always applicable to structure modified by an STC. Nonetheless, it is expected that all structure modified by STC should be evaluated by the operator and if possible in conjunction with the STC holder. Part 26.370 requires the operator to amend their maintenance programme to address all such repairs and a conservative extension of the TCHs REG to all STCs containing FCS can be envisaged to ensure all repairs to FCS are identified. Subsequently each repair can be subject to DTE with the support of a DAH and DTI provided. The STC holder should ~~develop, submit, and gain Agency approval of guidelines to evaluate repairs to such structure or~~ conduct specific damage tolerance assessments of known published repairs (SRM, SBs, etc.) and provide appropriate instructions to the operator.

It is expected that the STC holder will assist the operators by preparing the required documents. If the STC holder is ~~out of~~ no longer in business, or is otherwise unable to provide assistance, the operator would have to acquire the Agency-approved guidelines independently. ~~To keep the aircraft in service, it is always possible for operators, individually or as a group, to hire the necessary expertise to develop and gain approval of repair assessment guidelines and the associated DSG.~~ Ultimately, the operator remains responsible for the continued safe operation of the aircraft.

ANNEX 3

REPAIRS AND MODIFICATIONS TO REMOVABLE STRUCTURAL COMPONENTS

1. DETERMINING THE AGE OF A REMOVABLE STRUCTURAL COMPONENT

Determining the actual component's age or assigning a conservative age provides flexibility and reduces operator burden when implementing DT data for repairs and modifications to structural components. In some cases, the actual component's age may be determined from records. If the actual age cannot be determined this way, the component's age may be conservatively assigned using one of the following fleet leader concepts, depending upon the origin of the component:

- (a) If component times are not available, but records indicate that no part changes have occurred, aircraft flight cycles or flight hours can be used.
- (b) If no records are available, and the parts could have been switched from one or more older aircraft under the same maintenance programme, it should be assumed that the time on any component is equal to the oldest aircraft in the programme. If this is unknown, the time should be assumed equal to the same model aircraft that is the oldest or has the most flight cycles or flight hours in the world fleet.
- (c) A manufacturing date marked on a component may also be used to help establish the component's age in flight cycles or flight hours. This can be done by using the above reasoning and comparing it to aircraft in the affected fleet with the same or older manufacturing date.

If none of these options can be used to determine or assign a component age or total number of flight cycles or flight hours, a conservative implementation schedule can be established by using the guidelines applied in paragraph 3 of this Appendix, for the initial inspection, if required by the DT data.

2. TRACKING

An effective, formal control or tracking system should be established for removable structural components that are identified as FCBS or that contain FCS. This will help ensure compliance with the maintenance programme's requirements specific to repairs and modifications installed on an affected removable structural component. Paragraph 4 of this Appendix provides options that could be used to alleviate some of the burden associated with tracking all repairs to affected removable structural components.

3. DEVELOPING AND IMPLEMENTING DT DATA

(a) Repairs

Accomplish the initial repair assessment of the affected structural component at the same time as the aircraft level repair survey for the aircraft on which the component is installed. Develop DT data according to the process given in Step 3 of Appendix 6 and incorporate DTI into the maintenance programme.

(b) Modifications

Accomplish the initial modification assessment of the affected structural component at the same time as the aircraft level modification assessment for the aircraft on which the component is installed. Develop DT data and incorporate DTI into the maintenance programme.

If the actual age of the repairs or modification installation, or the total number of flight cycles or flight hours is known, use that information to establish when the initial

inspection of the component should be performed. Repeat the inspection at the intervals provided by the TCH or STC holder for the repair or modification installed on the component.

If the actual age of the repairs or modifications installation, or the total number of flight cycles or flight hours is unknown, but the component's age or total number of flight cycles or flight hours is known, or can be assigned conservatively, use the component's age, or total number of flight cycles or flight hours to establish when the initial inspection of the component should be performed. Repeat the inspection at the intervals provided by the TCH or STC holder for the repairs and modifications against the component.

As an option, accomplish the initial inspection of the affected component at the next C-check (or equivalent interval) following the repair assessment. Repeat the inspection at the intervals provided by the TCH or STC holder for the repairs and modifications against the component.

4. EXISTING REPAIRS AND MODIFICATIONS — COMPONENTS RETRIEVED FROM STORAGE

- (a) If the time on the component (in flight cycles or flight hours) is known, or can be conservatively assigned, perform the following:
 - (1) survey the component;
 - (2) dispose repairs and modifications;
 - (3) implement any DTI in accordance with the approved schedule;
 - (4) accomplish the initial inspection using the actual age of the repairs or modifications, or total number of flight cycles or flight hours, if known. If the age of the repairs or modifications is not known, use the component's age. Repeat the inspection at the intervals given for the repairs or modifications against the component.
- (b) If the time on the component (in flight cycles or flight hours) is unknown and cannot be conservatively assigned, perform the initial repair or modification assessment of the affected component prior to installation, and perform the following actions:
 - (1) develop DT data according to the process given in paragraph 3 or 4 of Appendix 3 to this AMC as applicable;
 - (2) incorporate any DTI into the maintenance programme;
 - (3) accomplish the first inspection on the affected component at the next C-check (or equivalent interval) following the repair or modification assessment;
 - (4) repeat the inspection at the intervals given for the repair or modification against the component.

5. IMPLEMENTATION OPTIONS TO HELP REDUCE TRACKING BURDEN

The following implementation techniques could be used to alleviate some of the burden associated with tracking repairs to affected removable structural components. These techniques, if used, would need to be included in the maintenance programme and may require additional EASA approval and TCH or STC holder input for DTI.

(a) Upgrading existing repairs

As an option, existing repairs may be removed and replaced to zero time the DTI requirements of the repair and establish an initial tracking point for the repair. Normally,

this would be done at or before the survey for maximum benefit. The initial and repetitive inspections for the upgraded repair would then be accomplished at the intervals given for the repair against the component.

A repair could also be upgraded to one whose inspection requirements and methods are already fulfilled by an operator's maintenance or inspection programme. That repair would then be repetitively inspected at each routine inspection interval applicable to the repair. Specific tracking would not be required because that area of the aircraft would have already been normally inspected on each aircraft in the fleet as part of the existing approved maintenance programme. If the operator's programme intervals were changed, the effect on requirements for specific tracking would have to be re-evaluated.

(b) Special initial and/or routine inspections

As an option, existing repairs may have special initial inspections accomplished during the component survey. This initial inspection establishes an initial tracking point for the repair. Following this initial inspection, the DTI requirements (e.g. repetitive inspections) of the repair would be implemented.

In addition, special routine inspections could be defined for typical repairs that could be applied at a normal interval. In this case, an operator could check the affected components on each aircraft for this type of a repair at the defined interval. If the repair is found, the special inspection would be applied to ensure its airworthiness until the next scheduled check. This alleviates the need to specifically track affected components for every repair, especially typical ones.

The development of inspection processes, methods, applicability and intervals will probably require the assistance of the TCH or STC holder for the FCS in question.

ANNEX 4

SERVICE BULLETIN REVIEW PROCESS

Guidelines for following the Service Bulletin (SB) flow chart

Note: While it is believed that this guidance is fairly comprehensive, it may not address every possible situation. It is therefore incumbent on the user to use good judgment and rationale when making any determination.

Screening SBs to determine which ones require DT data is primarily a TCH responsibility.

The result of this screening is a list of SBs which require special directed inspections to ensure continued airworthiness. SBs included in the list will be grouped into Type I and Type II SBs. Type I SBs have existing DT data and Type II SBs require developing DT data. The list is not comprehensive and will not include all the SBs associated with an aircraft. Specifically, the list will not include those SBs where a BZI programme developed for the repair assessment programme has been determined to be sufficient to meet the damage tolerance requirements for the FCBS that is affected by the SB. A note should be prominently placed somewhere in the compliance document stating that SBs not included in the list satisfy the DT data requirement.

'ALL SERVICE BULLETINS HAVE BEEN EVALUATED FOR DAMAGE TOLERANCE INSPECTION REQUIREMENTS; SERVICE BULLETINS NOT INCLUDED IN THIS LIST HAVE BEEN DETERMINED TO SATISFY THE DAMAGE TOLERANCE REQUIREMENT BY INSPECTIONS COVERED IN THE BZI. THE BZI IS DOCUMENTED IN SECTION X.XXX.XX.X OF THE MAINTENANCE PLANNING DOCUMENT.'

Query 1: Does the SB address a structural repair or a modification to FCS?

Historically, any SB, service letter or other document that lists ATA chapters 51 through 57 could provide repair or modification instructions that may require DT data. In addition, certain repairs or modifications accomplished under other ATA chapters may affect FCS. The first step in the screening process is to identify all such service instructions and develop a list of candidates for review (Q2).

Query 2: Does the service instruction specify either a repair or modification that creates or affects FCS?

If it does, then the service instruction requires further review (Q3). If it does not, then the service instruction does not require further review.

Query 3: Is the service instruction mandated?

Service Bulletins and other service instructions that are mandated by an AD have requirements to ensure that inspection findings (e.g. detected cracks or other structural damage/degradation) are addressed in an approved manner. If the TCH can demonstrate that they apply a process for developing inspection programmes for mandated SBs using DT data and/or service-based inspection results, and for continuously reviewing the SBs for their adequacy to detect cracks in a timely manner, the mandated SBs should then be considered as compliant with the intent of this process. Otherwise, the TCH will need to demonstrate that the inspection programme in the mandated SB has been developed using DT data and/or appropriate service-based inspection results. The outcome of Query 3 branches to two unrelated boxes (Q4: if mandated by an AD, or Q7: if not mandated by an AD).

Query 4: Does the SB or service instruction contain terminating action?

Query 3 established that the inspection programme for the baseline configuration is acceptable.

Query 5: Does the terminating action have DT data?

If the terminating action has a documented continuing airworthiness inspection programme based on damage tolerance principals, then no further review is required. The SB should be documented in the list. If the terminating action does not have DT data, or the status of the inspection programme cannot be verified, then further review is necessary (Q6).

Query 6: Does the SB address a safe-life part?

If it does, no further action is required. Otherwise, damage tolerance-based inspections will need to be developed and provided to the operators. The SB should be included in the list along with where to find the required continued airworthiness inspection programme.

Query 7: In Query 3 a structural SB that was mandated by AD was identified.

Query 7 asks if a one-time inspection is required to satisfy the intent of the requirement. If it does, it is deemed that this is being done to verify that a condition does not exist and, on finding that condition, correct that condition to baseline configuration. As such, normal SSID programmes would then be expected to cover any required continued airworthiness inspections. If a repair is necessary, it is further assumed that this was done by reference to the SRM or other suitable means. No further action is required if this is the case and, if a repair was necessary, other means exist to determine the required DT data. If no inspections or multiple inspections are required, additional evaluation is required (Q8).

Query 8: Is this a major structural design change (e.g. modification)?

This is a TCH decision that is part of the original certification process and is not a major/minor repair decision. If it is not a major design change then proceed to Q10; if not, proceed to Q9.

Query 9: Does the change require non-destructive inspections to verify the integrity of the structure or are normal routine maintenance inspections (as delineated in the BZI) sufficient?

This is a subjective question and may require re-evaluating the change and determining where specific fatigue cracking might be expected. If normal maintenance inspections are adequate, no further action is required. Otherwise, proceed to Q10.

Query 10: Does the SB contain DT data for both the baseline and modified aircraft configurations?

If so, the SB is satisfactory. Otherwise, damage tolerance-based inspections will need to be developed and provided to the operators. The SB should be documented in the list along with where to find the required continued airworthiness inspection programme.

Service Bulletin screening procedure

1. The TCH will perform the screening and the Structures Task Group will validate the results.
2. A list of all SBs requiring action will be included in the TCH compliance document. Those not requiring action will not be included in the list.
3. Service Bulletins included in the list will fall into one of the two general types:
Type I — SBs which have existing DT data.
Type II — Service Bulletins that require developing DT data.
4. TCH actions:
Type I — No action required.
Type II — Develop DT data and make it available to operators.
5. Operator actions (apply to both SB types):
 - Review SB incorporation on a tail number basis.
 - For incorporated SBs that rely on BZI (i.e. no special inspections required based on DTE performed), reconcile any maintenance planning document structural inspection escalations.
 - For incorporated SBs that require DTI, verify that DTI has been included in the operations specification and include it if it is missing.

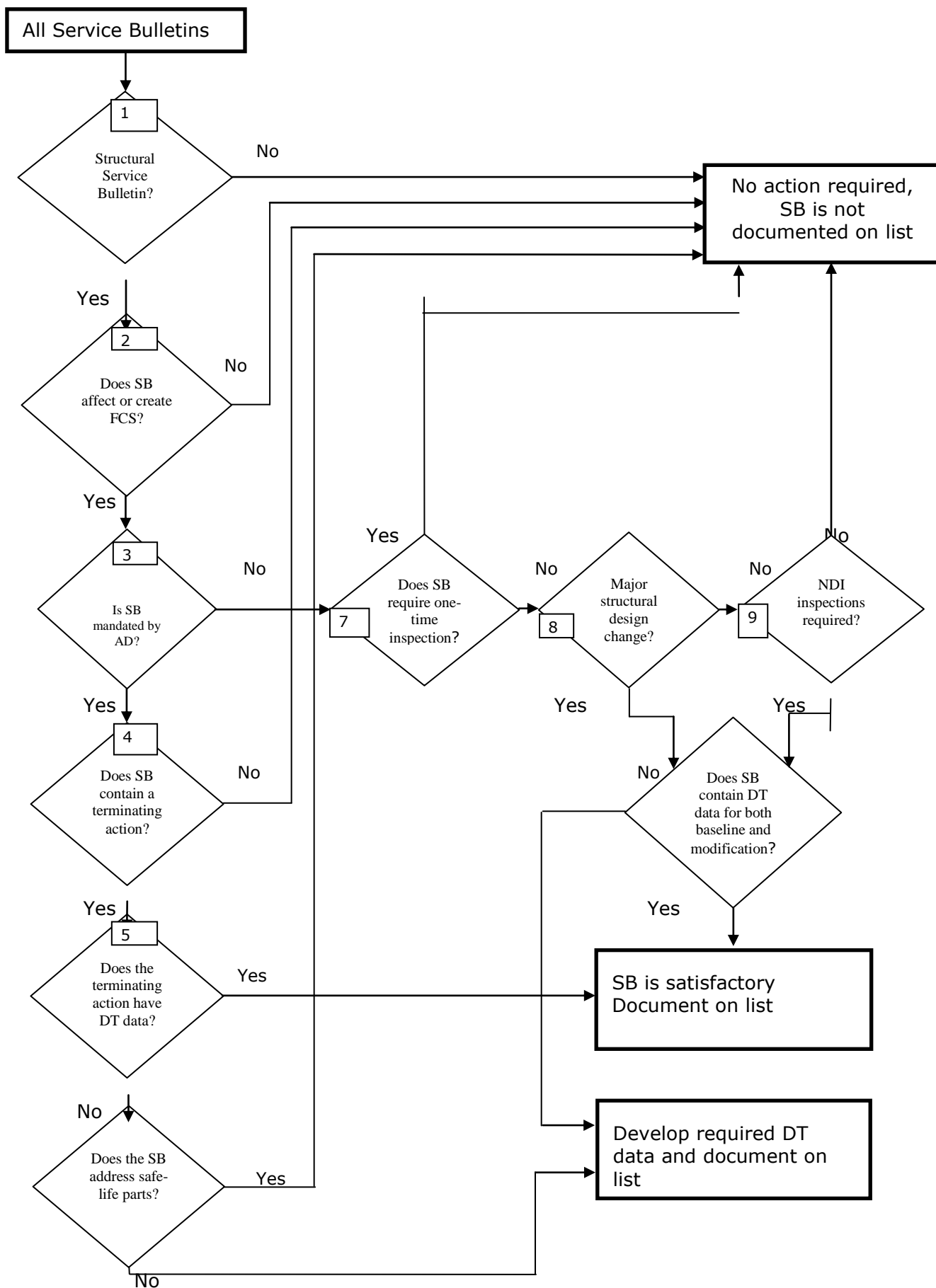

Figure A3(4)-1: Service Bulletin (SB) flow chart

ANNEX 5

LIST OF SIGNIFICANT STCs THAT MAY ADVERSELY AFFECT FATIGUE-CRITICAL STRUCTURE

- (1) Passenger-to-freighter conversions (including addition of main deck cargo doors).
- (2) Gross weight increases (increased operating weights, increased zero fuel weights, increased landing weights, and increased maximum take-off weights).
- (3) Installation of fuselage cut-outs (passenger entry doors, emergency exit doors or crew escape hatches, fuselage access doors, and cabin window relocations).
- (4) Complete re-engine or pylon modifications.
- (5) Engine hush kits.
- (6) Wing modifications such as installing winglets or changes in flight control settings (flap droop), and modification of wing trailing edge structure.
- (7) Modified skin splices.
- (8) Antenna installations.
- (9) Any modification that affects several stringer or frame bays.
- (10) Any modification that covers structure requiring periodic inspection by the operator's maintenance programme.
- (11) Any modification that results in operational mission change that significantly changes the manufacturer's load or stress spectrum (e.g. passenger-to-freighter conversion).
- (12) Any modification that changes areas of the fuselage that prevents external visual inspection (e.g. installation of a large external fuselage doubler that results in hiding details beneath it).
- (13) In general, attachment of interior monuments to FCS. Interior monuments include large items of mass such as galleys, closets, and lavatories.

APPENDIX 4

GUIDELINES FOR THE DEVELOPMENT OF A CORROSION PREVENTION AND CONTROL PROGRAMME

1. GENERAL

Before an operator may include a new Corrosion Prevention and Control Programme CPCP in their maintenance or inspection programme, the Agency should review and approve that CPCP. The Agency review is intended to ensure that the CPCP is comprehensive and systematic. The operator should show that the CPCP is comprehensive in that it addresses all corrosion likely to affect primary structure, and systematic in that whether it provides:

- (a) step-by-step procedures that are applied on a regular basis to each identified task area or zone; and
- (b) these procedures are adjusted when they result in evidence that corrosion is not being controlled to an established acceptable level (Level 1 or better).

1.1. Purpose

This Appendix gives guidance to operators and DAHs who are developing and implementing a CPCP for aeroplanes maintained in accordance with a maintenance programme developed in compliance with Part-M M.A.302.

CPCPs have been developed by the DAH with the assistance of aircraft operators and competent authorities. They relied heavily on service experience to establish CPCP implementation thresholds and repeat intervals. Since that time a logical evaluation process that has been developed to ensure environmental damage is considered in the evaluation of aircraft structure. This process is identified in the ATA MSG-3 Scheduled maintenance development document, which introduced the CPCP concept in revision 2, circa 1993. The Agency will accept a CPCP based on this document and the information in this advisory circular AMC. The Agency will also accept any other process that follows the guidelines of this AMC.

1.2. Approval

Approval of a TCH CPCP may either be through the MRB (ISC) using existing procedures for EASA MRBR approval or directly by the Agency if no EASA-approved MRBR exists for the type. Provided the operator has an NAA-approved MP that controls corrosion to Level 1 or better it need not follow exactly the programme offered by the TCH. However, revisions to the TCH's approved programme must be considered by the operator for incorporation in the operator's MP under Part-M requirements.

2. DEFINITIONS

- **Allowable limit** is the amount of material (usually expressed in material thickness) that may be removed or blended out without affecting the ultimate design strength capability of the structural member. Allowable limits may be established by the TCH/DAH. The Agency may also establish allowable limits. The DAH normally publishes allowable limits in the SRM or in SBs.
- **Baseline programme** is a CPCP developed for a specific aeroplane model. The TCH typically develops the baseline programme (see TCH Developed Baseline Programme below). However, it may be developed by a group of operators who intend to use it in developing their individual CPCP (see 'Operator-developed

programme' below). It contains the corrosion inspection tasks, an implementation threshold, and a repeat interval for task accomplishment in each area or zone.

- **Basic task(s)** is a specific and fundamental set of work elements that should be performed repetitively in all task areas or zones to successfully control corrosion. The contents of the basic task may vary depending upon the specific requirements in an aeroplane area or zone. The basic task is developed to protect the primary structure of the aeroplane.
- **Corrosion Prevention and Control Programme (CPCP)** is a comprehensive and systematic approach to control corrosion in such a way that the load carrying capability of an aircraft structure is not degraded below a level necessary to maintain airworthiness. It is based upon the baseline programme described above. A CPCP consists of ~~It contains the~~ a basic corrosion inspection task, task areas, defined corrosion levels, and compliance times (implementation thresholds and repeat intervals). The CPCP also includes procedures to notify the competent authority of the findings and data associated with Level 2 and Level 3 corrosion and the actions taken to reduce future findings to Level 1.
- **Implementation Threshold (IT)** is the aircraft age associated with the first time the basic corrosion inspection task should be accomplished in an area or zone.
- **Level 1 corrosion** is:
 - (a) corrosion occurring between successive corrosion inspection tasks that is local and can be reworked or blended out within the allowable limit; or
 - (b) corrosion damage that is local and exceeds the allowable limit, but can be attributed to an event not typical of operator's usage of other aircraft in the same fleet (e.g. mercury spill); or
 - (c) operator experience has demonstrated only light corrosion between each successive corrosion inspection task inspection, and the latest corrosion inspection task results in rework or blend-out that exceeds the allowable limit.
- **Level 2 corrosion** is that corrosion occurring between any of the two successive corrosion inspection tasks that requires a single rework or blend-out which exceeds the allowable limit.

OR

corrosion occurring between successive inspections that is widespread and requires a single blend-out approaching allowable rework limit, i.e. it is not light corrosion as provided for in Level 1, definition (3).

A finding of Level 2 corrosion requires repair, reinforcement, or complete or partial replacement of the applicable structure.

Note: A statement of fact in previously mandated CPCPs states: corrosion findings that were discovered during the corrosion inspection task accomplished at the implementation threshold, and which require repair, reinforcement, or complete or partial replacement of the applicable structure, should not be used as an indicator of the effectiveness of the operator's CPCP. The argument is that an operator's corrosion programme effectiveness can only be determined after a repeat inspection has been performed in a given inspection task area. This argument is valid for aircraft with mandated CPCPs introduced after the aircraft has been in service for a number of years without a CPCP. This argument, however, may not be valid for aircraft that have been maintained using a DAH's CPCP. Consequently, corrosion findings exceeding Level 1 found on the corrosion inspection task implementation

threshold may have been set too high by the DAH and action should be taken to readjust the implementation threshold.

- **Level 3 corrosion** is that corrosion occurring during the first or subsequent accomplishments of a corrosion inspection task that the operator determines to be an urgent airworthiness concern.

Note: If Level 3 corrosion is determined at the implementation threshold or any repeat inspection then it should be reported. Any corrosion that is more than the maximum acceptable to the DAH or the Agency must be reported in accordance with the current regulations. This determination should be conducted jointly with the DAH.

- **Light corrosion** is corrosion damage so slight that removal and blend-out over multiple repeat intervals (RI) may be accomplished before material loss exceeds the allowable limit.
- **Local corrosion.** Generally, local corrosion is corrosion of a skin or web (wing, fuselage, empennage or strut) that does not exceed one frame, stringer, or stiffener bay. Local corrosion is typically limited to a single frame, chord, stringer or stiffener, or corrosion of more than one frame, chord, stringer or stiffener where no corrosion exists on two adjacent members on each side of the corroded member.
- **Operator-developed programme.** In order to operate an aeroplane in compliance with the maintenance programme of Part-M an operator should include in their maintenance or inspection programme an approved CPCP. An operator may adopt the baseline programme provided by the DAH or they may choose to develop their own CPCP, or may be required to if none is available from the DAH. In developing their own CPCP an operator may join with other operators and develop a baseline programme similar to a TCH-developed Baseline Programme for use by all operators in the group. The advantages of an operator-developed Baseline Programme are that it provides a common basis for all operators in the group to develop their CPCP and it provides a broader experience base for development of the corrosion inspection tasks and identification of the task areas.
- **Repeat Interval (RI)** is the calendar time between the accomplishment of successive corrosion inspection tasks for a task area or zone.
- **Task area** is a region of aircraft structure to which one or more corrosion inspection tasks are assigned. The task area may also be referred to as a zone.
- **TCH-developed Baseline Programme.** As part of the ICA, the TCH should provide an inspection programme that includes the frequency and extent of inspections necessary to provide the continued airworthiness of the aircraft. Furthermore, the ICA should include the information needed to apply protective treatments to the structure after inspection. In order for the inspections to be effectively accomplished, the TCH should include, in the ICA, corrosion removal and cleaning procedures and reference allowable limits. The TCH should include all of these corrosion-related activities in a manual, referred to as the Baseline Programme. The Baseline Programme manual is intended to facilitate operator development of a CPCP for their maintenance programme.
- **Urgent airworthiness concern** is damage that could jeopardise continued safe operation of any aircraft. An urgent airworthiness concern typically requires correction before the next flight and expeditious action to inspect the other aircraft in the operator's fleet.

- **Widespread corrosion** is corrosion of two or more adjacent skin or web bays (a web bay is defined by frame, stringer or stiffener spacing). Or widespread corrosion is corrosion of two or more adjacent frames, chords, stringers, or stiffeners. Or widespread corrosion is corrosion of a frame, chord, stringer, or stiffener and an adjacent skin or web bay.
- **Zone.** See 'Task area'.

3. DEVELOPMENT OF A BASELINE PROGRAMME

3.1. Baseline Programme

The objective of a Baseline Programme is to establish requirements for control of corrosion of aircraft structure to Level 1 or better for the operational life of the aircraft. The Baseline Programme should include the basic task, implementation thresholds, and repeat intervals. The Baseline Programme should also include procedures to notify the competent authority of the findings and data associated with Level 2 and Level 3 corrosion and the actions taken to reduce future findings to Level 1.

3.1.1. Baseline Programme considerations

To establish an effective Baseline Programme consideration of the following is necessary:

- (a) the flight and maintenance history of the aircraft model and perhaps similar models;
- (b) the corrosion properties of the materials used in the aircraft structure;
- (c) the protective treatments used;
- (d) the general practice applied during construction and maintenance; and
- (e) local and widespread corrosion (see Figure A4-1).

When determining the detail of the corrosion inspection tasks, the implementation threshold and the repeat interval, a realistic operational environment should be considered. Technical representatives of both the TCH and the operators should participate in evaluating the service history and operational environment for the aircraft model. For new aircraft models and for aircraft models that have been in operation for only a short time, technical representatives of operators of similar aircraft models should be invited to participate.

EXAMPLES OF LOCAL AND WIDESPREAD CORROSION IN FUSELAGE FRAMES

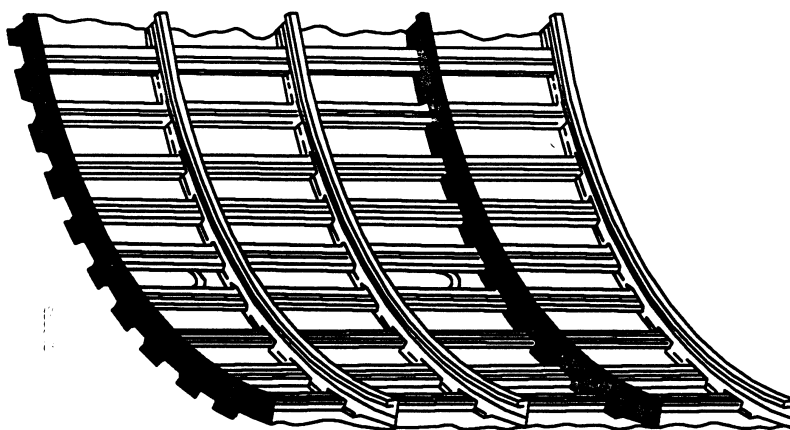

LOCAL CORROSION

(Corrosion occurring in non-adjacent frames)

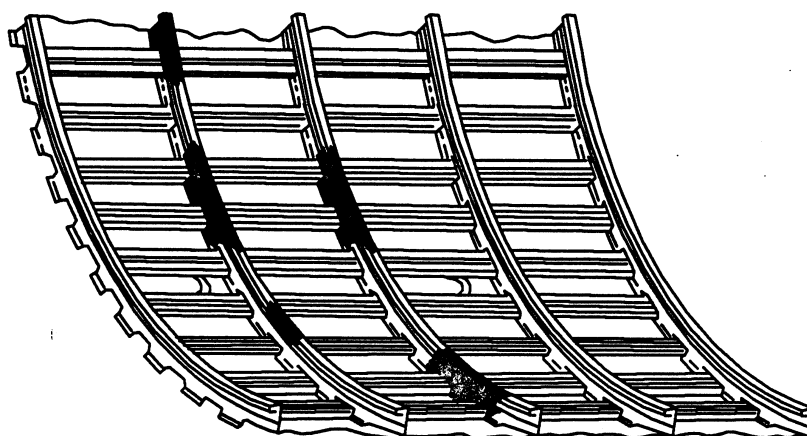

WIDESPREAD CORROSION

(Corrosion occurring in adjacent frames)

Figure A4-1

3.1.2. TCH-developed Baseline Programme

During the design development process, the TCH should provide a Baseline Programme as part of the instructions for continued airworthiness. The TCH initially evaluates service history of corrosion available for aircraft of similar design used in the same operational environment. Where no similar design with service experience exists those structural features concerned should be assessed using the environmental damage approach of ATA MSG-3. The TCH develops a preliminary Baseline Programme based on this evaluation. The TCH then convenes a working group consisting of operator technical representatives and representatives of the participating competent authorities. The working group reviews the preliminary Baseline Programme to assure that the tasks, implementation thresholds and repeat intervals are practical and assure the continued airworthiness of the aircraft. Once the working group review is complete, the TCH incorporates the Baseline Programme into the instructions for continued airworthiness (see Figure A4-2).

Figure A4-2: TCH-developed Baseline Programme

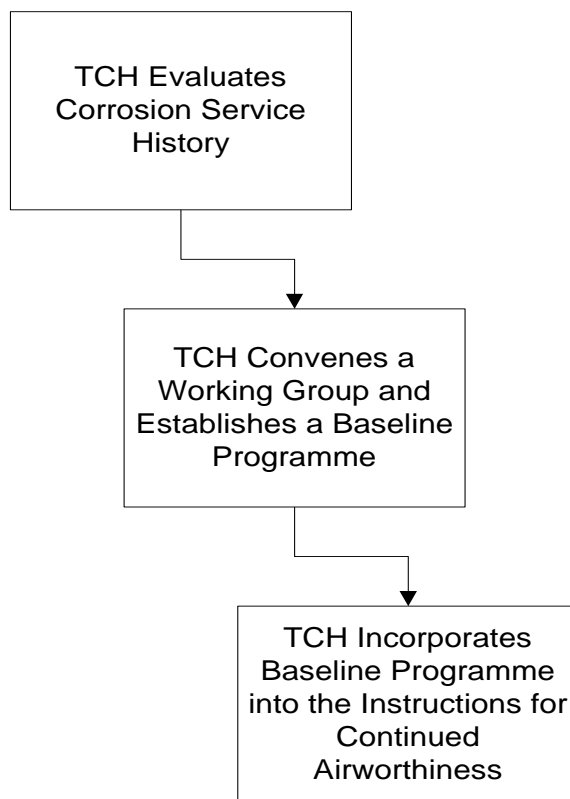

3.1.3. Operator-developed programme

There may be instances where the TCH does not provide a Baseline Programme. In such instances, an operator may develop their CPCP without using a Baseline Programme, as long as the operator-developed CPCP is consistent with the requirements. It would be beneficial for an operator developing their own CPCP to consult other operators of the same or similar aircraft models in order to broaden the service experience available for use in preparing their programme. When a TCH-prepared Baseline Programme is unavailable, a group of operators may prepare a Baseline Programme from which each operator in the group will develop their CPCP.

(a) Operator-developed Baseline Programme

An operator-developed Baseline Programme should particularly focus on the areas of the aircraft prone to corrosion, such as:

- (i) exhaust trail areas,
- (ii) battery compartments and battery vent openings,
- (iii) areas surrounding lavatories, buffets and galleys,
- (iv) bilges,
- (v) fuselage internal lower structure,
- (vi) wheel wells and landing gear,

- (vii) external skin areas,
- (viii) water entrapment areas,
- (ix) engine frontal areas and cooling air vents,
- (x) electronic or avionics compartments, and
- (xi) flight control cavities open during take-off and landing.

Note: CPCPs for large transport aeroplanes were developed based on a triad amongst the Airworthiness Authorities, DAHs, and the operators for the particular aeroplane model. If operator(s) were to develop a CPCP they may want to follow the example of the large transports.

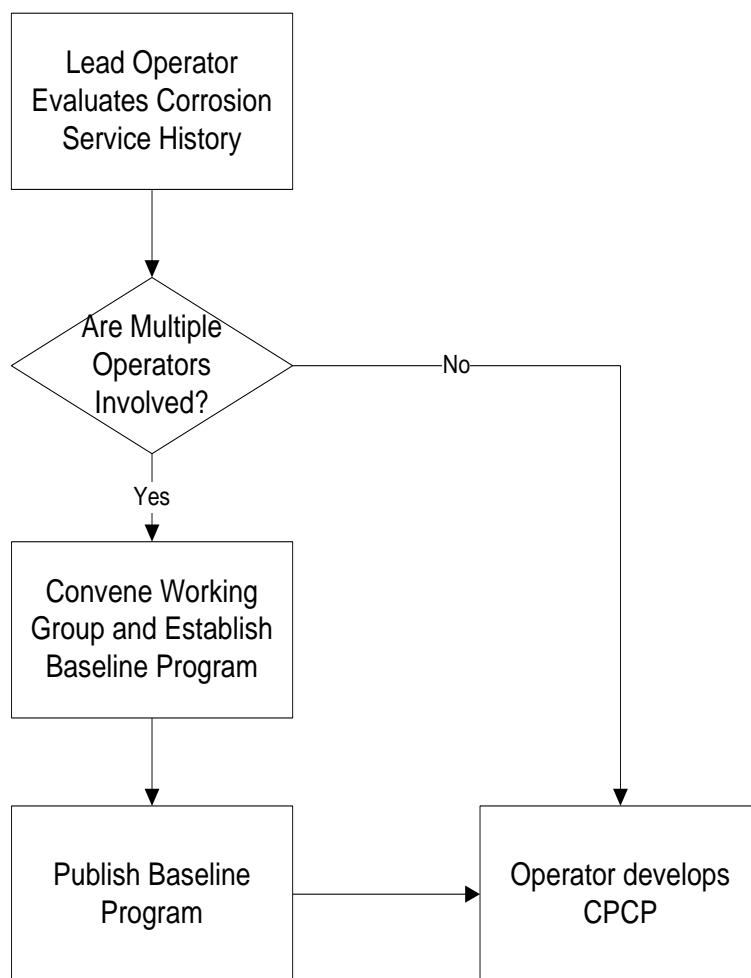

(b) Individual operator-developed CPCP

An operator may develop their CPCP without reference to a Baseline Programme as long as the CPCP is consistent with the requirements of the applicable operating rules. Any operator who develops their own CPCP without a Baseline Programme, should review all available corrosion-related service data on the individual aircraft model and similar

design details in similar aircraft models when the operator's data and the Service Difficulty Report data show no entries.

3.1.4. Continuous analysis and surveillance

The operator's continuous analysis and surveillance system should contain procedures to review corrosion inspection task findings and establish corrosion levels. These procedures should provide criteria for determining if findings that exceed allowable limits are an isolated incident not typical of the operator's fleet. The operator's programme should also provide for notifying the competent authority whenever a determination of Level 2 or Level 3 corrosion is made. Due to the potential urgent airworthiness concern associated with a Level 3 finding, the operator's procedures should provide for notification as soon as possible but not later than 3 calendar days after a Level 3 determination has been made.

3.2. Baseline Programme manual

The Baseline Programme manual should include instructions to implement the baseline CPCP. It may be in a printed form or other form acceptable to the competent authority. It should also be in a form that is easy to revise. The date of the last revision should be entered on each page. The Baseline Programme manual should clearly be identified as a baseline CPCP programme. The aircraft make, model and the person who prepared the manual should also be identified.

3.2.1. Purpose and background

This section of the manual should state the purpose of the Baseline Programme, which is to establish minimum requirements for preventing and controlling corrosion that may jeopardise continuing airworthiness of the aircraft model fleet. The section should further state that an operator should include an effective CPCP in their maintenance or inspection programme.

3.2.2. Introduction

The introduction should include a general statement that corrosion becomes more widespread as aircraft age and that it is more likely to occur in conjunction with other damage such as fatigue cracking. The introduction should also indicate that it is not the intent of a CPCP to establish rigid requirements to eliminate all corrosion in the fleet, but to control corrosion at or below levels that do not jeopardise continued airworthiness. However, due to the unpredictability of corrosion it must be removed and the structure repaired and corrosion prevention treatment reapplied.

3.2.3. Programme application

For a programme to be fully effective, it is essential that a corrosion inspection task be applied to all areas where corrosion may affect Primary Structure. This section should recommend that priority for implementing the CPCP be given to older aeroplanes and to areas requiring significant changes to previous maintenance procedures in order to meet corrosion prevention and control requirements. This section should allow an operator to continue their current corrosion control procedures in a given task area or zone where there is documentation to show that corrosion is being consistently controlled to Level 1.

3.2.4. Baseline Programme

This section should fully describe the Baseline Programme. It should include the basic task, corrosion inspection task areas, implementation thresholds, and repeat intervals.

3.2.5. Reporting system

Procedures to report findings of Level 2 and Level 3 corrosion to the competent authority should be clearly established in this section. All Level 2 and Level 3 findings should be reported in accordance with the applicable AD, operator's service difficulty reporting procedures or reporting required by other competent authorities. Additional procedures for alerting the competent authority of Level 3 findings should be established that expedite such reporting. This report to the competent authority shall be made after the determination of the corrosion level.

3.2.6. Periodic review

This section should establish a period for the TCH (or lead operator) and participating operators to meet with the competent authority and review the reported Level 2 and Level 3 findings. The purpose of this review is to assess the Baseline Programme and make adjustments if necessary.

3.2.7. Corrosion-related Airworthiness Directives

This section should include a list of all ADs that contain requirements related to known corrosion-related problems. This section should state that these ADs are in addition to and take precedence over the operator's CPCP.

3.2.8. Development of the Baseline Programme

This section should identify the actions taken in preparing the Baseline Programme. It should include a description of the participants, the documents (e.g. SBs, service letters, ADs, service difficulty reports, accident and incident reports) reviewed, and the methodology for selecting and categorising the corrosion-prone areas to be included in the Baseline Programme. The selection criteria for corrosion-prone areas should be based on areas having similar corrosion exposure characteristics and inspection access requirements. Some corrosion-prone areas that should be considered are the main wing box, the fuselage crown, the bilge, areas under lavatories and galleys, etc. This section should state that the implementation threshold was selected to represent the typical aircraft age beyond which an effective corrosion inspection task should be implemented for a given task area.

3.2.9. Procedures for recording corrosion inspection findings

The Agency has not imposed a requirement for additional record keeping for an operator's CPCP. However, the operator should maintain adequate records to substantiate any proposed programme adjustments. For example, an operator should maintain records to enable the operator to determine the amount of damage that has occurred during the repeat interval for each corrosion inspection task. Such data should be maintained for multiple repeat intervals in order to determine whether the damage remains constant or is increasing or decreasing. Such records are necessary when an operator is seeking approval for interval extension (escalation) or task reduction.

3.2.10. Glossary

This section should define all terms specifically used in the baseline manual.

3.2.11. Application of the basic task

This section should describe in detail the basic task. It should provide procedures describing how to accomplish the following actions:

- (a) Removal of all systems equipment and interior furnishings to allow access to the area.
- (b) Cleaning of the area as required.
- (c) Visual inspection of all task areas and zones listed in the Baseline Programme.
- (d) Removal of all corrosion, damage evaluation, and repair of structure as necessary.
- (e) Unblocking holes and gaps that may hinder drainage.
- (f) Application of corrosion protective compounds.
- (g) Reinstallation of dry insulation blankets, if applicable.

3.2.12. Determination of corrosion levels based on findings

This section should describe how the corrosion level definitions are used in evaluating the corrosion findings and assigning a corrosion level. This section should also instruct the operator to consult the DAH or the competent authority for advice in determining corrosion levels.

3.2.13. Typical actions following determination of corrosion levels

This section should establish criteria for evaluating whether or not Level 2 or Level 3 corrosion is occurring on other aircraft in the operator's fleet. Criteria to be considered include: cause of the corrosion problem, past maintenance history, operating environment, production build standard, years in service, and inspectability of the corroded area. These and any other identified criteria should be used in identifying those aircraft that should be included in a fleet campaign. The results of the fleet campaign should be used to determine necessary adjustments in the operator's CPCP. The following instructions should also be included in this section:

- (a) If corrosion exceeding the allowable limit is found during accomplishment of the corrosion inspection task implementation threshold for a task area, it may be necessary to adjust the CPCP. (See 'NOTE' under 'Level 2 corrosion' definition)
- (b) A single isolated occurrence of corrosion between successive inspections that exceeds Level 1 does not necessarily warrant a change in the operators CPCP. If the operator experiences multiple occurrences of Level 2 or Level 3 corrosion for a specific task area, then the operator should implement a change to the CPCP.
- (c) The operator should not defer maintenance actions for Level 2 and Level 3 corrosion. These maintenance actions should be accomplished in accordance with the operator's maintenance manual.
- (d) The operator may implement changes such as the following to improve the effectiveness of the programme:
 - (1) reduction of the repeat interval,
 - (2) multiple applications of corrosion treatments,
 - (3) additional drainage provisions,
 - (4) incorporation of DAHs service information, such as Service Bulletins and service letters.

3.2.14. Programme implementation

This section should state that each task is to be implemented on each aircraft when the aircraft reaches the age represented by the implementation threshold for the task. It

should also describe procedures to be used for establishing a schedule for implementation where the aircraft age exceeds the implementation threshold for individual tasks. It should state that once a task is implemented in an area, subsequent tasks are to be accomplished at the repeat interval in that task area.

4. DEVELOPMENT OF OPERATORS PROGRAMME

4.1. Baseline Programme available

If a Baseline Programme is available, the operator should use it as a basis for developing their CPCP. In addition to adopting the basic task, task areas, implementation thresholds and repeat intervals of the Baseline Programme, the operator should make provisions for:

- (a) aeroplanes that have exceeded the implementation threshold for certain tasks,
- (b) aeroplanes being removed from storage,
- (c) unanticipated scheduling adjustments,
- (d) corrosion findings made during non-CPCP inspections,
- (e) adding newly acquired aircraft, and
- (f) modifications, configuration changes, and operating environment.

4.1.1. Provisions for aircraft that have exceeded the implementation threshold

The operator's CPCP must establish a schedule for accomplishing all corrosion inspection tasks in task areas where the aircraft age has exceeded the implementation threshold (see main text of AMC paragraph 12). Repeat paragraph 12 text on implementation.

4.1.2. Aeroplanes being removed from storage

Corrosion inspection task intervals are established based on elapsed calendar time. Elapsed calendar time includes time out of service. The operator's CPCP should provide procedures for establishing a schedule for accomplishment of corrosion inspection tasks that have accrued during the storage period.

The schedule should result in accomplishment of all accrued corrosion inspection tasks before the aircraft is placed in service.

4.1.3. Unanticipated scheduling adjustments

The operators CPCP should include provisions for adjustment of the repeat interval for unanticipated schedule changes. Such provisions should not exceed 10 % of the repeat interval. The CPCP should include provisions for notifying the competent authority when an unanticipated scheduling adjustment is made.

4.1.4. Corrosion findings made during non-CPCP inspections

Corrosion findings that exceed allowable limits may be found during any scheduled or unscheduled maintenance or inspection activities. These findings may be indicative of an ineffective CPCP. The operator should make provision in their CPCP to evaluate these findings and adjust their CPCP accordingly.

4.1.5. Adding newly acquired aircraft

Before adding any aircraft to the fleet, the operator should establish a schedule for accomplishing all corrosion inspection tasks in all task areas that are due. This schedule should be established as follows:

- (a) For aircraft that have previously operated under an approved maintenance programme, the initial corrosion inspection task for the new operator must be accomplished in accordance with the previous operator's schedule or in accordance with the new operator's schedule, whichever would result in the earliest accomplishment of the corrosion inspection task.
- (b) For aircraft that have not previously been operated under an approved maintenance programme, each initial corrosion task inspection must be accomplished either before the aircraft is added to the operator's fleet, or in accordance with the schedule approved by the competent authority. After each corrosion inspection task has been performed once, the subsequent corrosion task inspections should be accomplished in accordance with the new operator's schedule.

4.1.6. Modifications, configuration changes and operating environment

The operator must ensure that their CPCP takes account of any modifications, configurations changes and the operating environment applicable to them, that were not addressed in the Baseline Programme manual.

4.2. Baseline Programme not available

If there is no Baseline Programme available for the operator to use in developing their CPCP, the operator should develop their CPCP using the provisions listed in paragraph 3 of this Appendix for a Baseline Programme as well as the provisions listed in subparagraphs 4.1.1 through 4.1.6 of this paragraph.

APPENDIX 5

GUIDELINES FOR THE FOR CONTINUED AIRWORTHINESS PROCESSES FOR CONTINUING STRUCTURAL INTEGRITY, INCLUDING DEVELOPMENT OF AN SB REVIEW AND MANDATORY MODIFICATION PROGRAMME (REF.: PART 26.300)

1. GENERAL

Part 26.300(f) 'Continued Airworthiness Procedures' requires that TCHs for large transport aeroplanes establish a new process or validate an existing process which ensures that unsafe levels of fatigue cracking will be precluded in service. These new or validated procedures and processes must include:

- (a) periodic monitoring of operational usage with comparison to design assumptions;
- (b) an assessment of the need for mandatory changes in cases where inspection alone is not reliable enough to ensure that unsafe levels of cracking are precluded.

Acceptable compliance for the monitoring of operational usage would be to review every five years the key operating variable parameters such as weight, fuel, payload, mission length, etc., and evaluate their influence on the fatigue analysis and inspection programme. In addition, a review is required whenever an extension of the LoV is requested.

In order to show compliance with Part 26.300(f) 'Continued Airworthiness Procedures', a summary of the TCH's procedures that address Part 26.300(f) and take into account the guidance of this AMC should be provided to the Agency (see Appendix 5 for further details). For non-EU TCHs verification will be requested from the NAA responsible for the TCH that those procedures assure compliance with Part 26.300(f).

This Appendix provides interpretation, guidelines and Agency accepted means of compliance for the review of service findings, structural Service Bulletins, other relevant inspections such as SSID and ALS including a procedure for selection, assessment and related recommended corrective action for ageing aircraft structures.

In addition, the TCH should ensure that processes are in place to address:

- (a) cracking detected and reported before the inspection threshold;
- (b) cracking that is generally being found at or near to the critical crack size;
- (c) changing cracking configurations for which the reasons are not fully understood; and
- (d) new cracking scenarios reported under existing inspection or repair procedures that could otherwise be considered addressed and overlooked.

The risks these issues present can be mitigated by:

- (a) Ensuring the CAW process and its implementation provide adequate monitoring of the relevant service data and trends within it and compare these to the existing substantiation.
- (b) Ensuring that all findings that could be relevant are reported, by providing clear instructions and easy to use reporting means to operators that encourage and facilitate both their support and that of the customer support staff in identifying developing risks.
- (c) Modifying structure so that a reasonably high probability exists that ultimate load capability will typically be retained over long periods of the aircraft's life and

significantly reducing the potential for interaction with new cracking that may develop later in the aircraft's life.

2. SB SELECTION PROCESS

The SB selection, review, assessment and recommendation process within the Structural Task Group (STG) is summarised in Figure A5-1. For the first SB review within STG meeting, all inspection SB should be selected. Afterwards, the TCH should update periodically a list of SBs which were already selected for a review with all decisions made, and add to this list all new and revised SBs. Moreover, some specific modification SBs not linked to an inspection SB may also be selected for review.

Operators information input should address the points as detailed in Figure A5-2. This information should be collected and analysed by the TCH for the STG meeting.

If for a given selected SB there is no sufficient in-service data available before the STG meeting that would enable a recommendation to be made, its review may be deferred until enough data is available. The TCH should then check periodically until these data become available.

The operators and the Agency should be advised by the TCH of the SB selection list and be given the opportunity to submit additional SBs. For this purpose, the TCH should give the operators enough information in advance (e.g. 2 months) for them to be able to properly consider the proposed selection and to gather data.

When an SB is selected, it is recommended to select also, in the same package, inspection SB that interact with it and all related modification SB. The main criteria for selecting SBs are defined in the following subparagraphs.

2.1 High probability that structural cracking exists

Related to the number and type of finding in service and from fatigue testing.

A 'no finding' result should be associated to the number of performed inspections.

The type of finding should include an analysis of its criticality.

2.2 Potential or increasing structural airworthiness concern

Structural airworthiness of the aircraft is dependent on repeat inspections to verify structural condition, and therefore on inspection reliability.

A short repeat inspection interval (e.g. short time to grow from detectable crack to a critical length divided by a factor) will lead to increased workload for inspectors and possible increased risk of missing damage.

Special attention should be paid to any single inspection tasks involving multiple repeat actions needed to verify the structural condition that may increase the risk of missing damage (e.g. lap splice inspections).

2.3 Damage is difficult to detect during regular maintenance

- (a) The areas to be inspected are difficult to access;
- (b) NDI methods are proving unsuitable;
- (c) Human factors associated with the inspection technique are so adverse that crack detection may not be sufficiently dependable to assure safety.

2.4 There is adjacent structural damage or the potential for it

Particular attention should be paid to areas susceptible to WFD and also to potential interaction between corrosion and fatigue cracking, e.g. between fastener damage (due to stress corrosion or other factors) and fatigue cracking.

It is recommended to consider the potential interaction of modifications or repairs usually implemented in the areas concerned to check whether the inspections are still reliable or not (operator's input).

3. STG MEETING, SB REVIEW AND RECOMMENDATIONS

It is recommended to review at the same time all SBs that can interact, the so-called SB package, in the selection process. The meeting should start with an STG agreement on the selected SB list and on those deferred. At the meeting the TCH should present their analysis of each SB utilising the collection of operator input data. The STG should then collectively review the ratings (Figure A5-2) against each criteria to reach a consensus recommendation. Such an STG recommendation for a selected SB shall consider the following options:

- (a) to mandate a structural modification at a given threshold,
- (b) to mandate selected inspection SB,
- (c) to revise modification or repair actions,
- (d) to revise other SB in the same area concerned by damages,
- (e) to review inspection method and related inspection intervals,
- (f) to review ALI/MRBR or other maintenance instructions,
- (g) to defer the review to the next STG and request operators' reports on findings for a specific SB or request an inspection sampling on the oldest aircraft.

STG recommendations for mandatory action are the responsibility of the TCH to forward to the Agency for appropriate action. Other STG recommendations is information provided to the STG members. It is their own responsibility to carry them out within the appropriate framework.

FIGURE A5-1: SB SELECTION PROCESS AND SB REVIEW

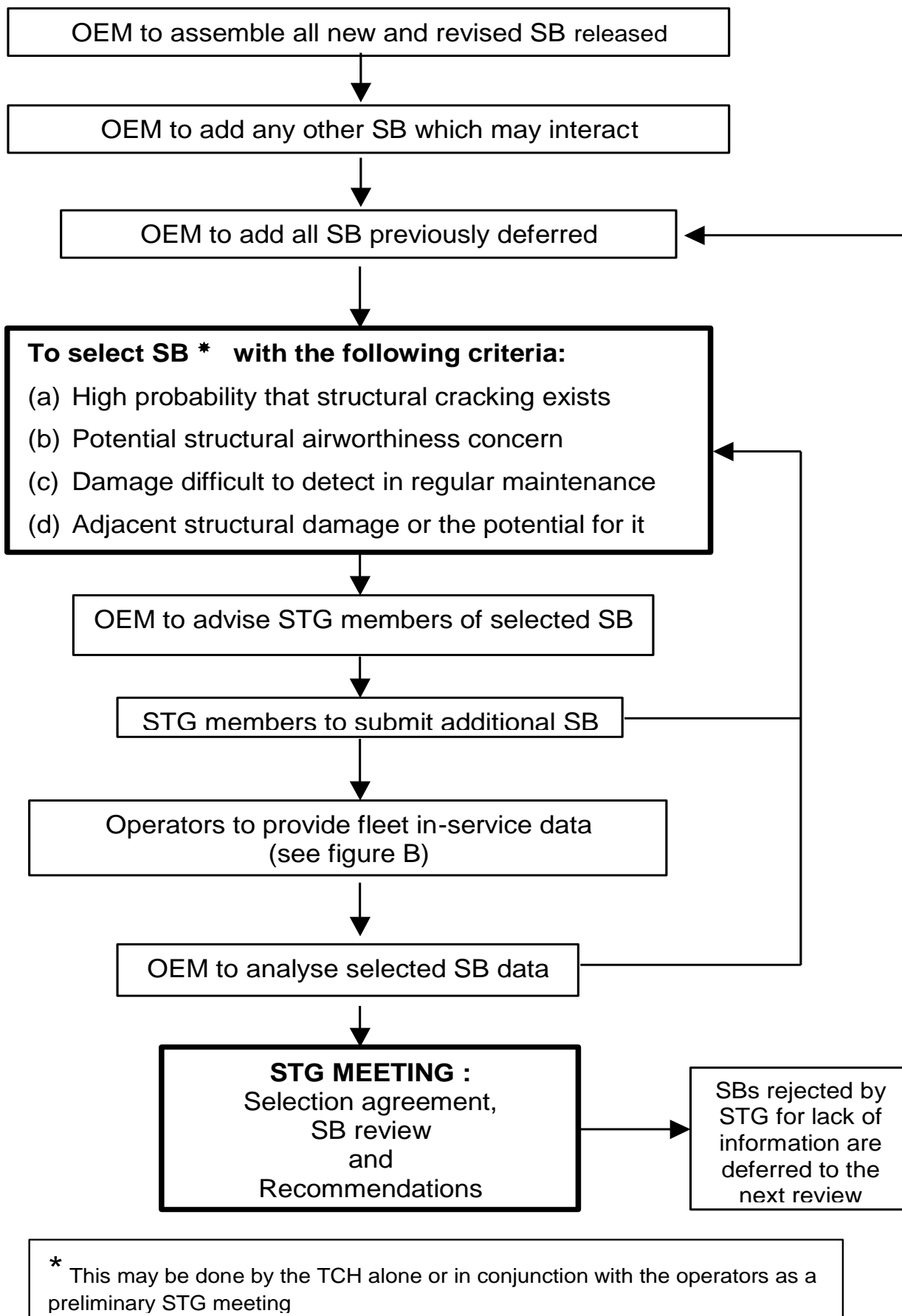

FIGURE A5-2: OPERATORS FLEET EXPERIENCE

IN-SERVICE DATA/SECTION 1

NAME OF THE OPERATOR
AIRCRAFT MODEL/SERIES
SERVICE BULLETIN (SB) NUMBER
TITLE
RELATED INSPECTION/MODIFICATION SB: 1/ _____ _____
2/ _____ _____
3/ _____ _____
SB MANDATED? <input type="checkbox"/> YES <input type="checkbox"/> NO IF NOT, SB IMPLEMENTED IN MAINTENANCE PROGRAMME? <input type="checkbox"/> YES <input type="checkbox"/> NO
NUMBER OF AIRCRAFT TO WHICH SB APPLIES (INCLUDING ALL A/C IN THE SB EFFECTIVITY) _____
NUMBER OF AIRCRAFT EXCEEDING SB INSPECTION THRESHOLD (IF APPLICABLE) _____
NUMBER OF AIRCRAFT INSPECTED PER SB (IF APPLICABLE)? _____
SPECIFY TYPE OF INSPECTION USED _____
NUMBER OF AIRCRAFT WITH REPORTED FINDINGS _____

TYPE OF FINDINGS

NUMBER OF FINDINGS DUE TO OTHER INSPECTIONS THAN THE ONE PRESCRIBED IN SB (IF APPLICABLE) _____
SPECIFY TYPE OF INSPECTION USED _____

<p>NUMBER OF AIRCRAFT EXCEEDING SB TERMINATING MODIFICATION THRESHOLD (IF APPLICABLE) _____</p> <p>NUMBER OF AIRCRAFT IN WHICH TERMINATING MODIFICATION HAS BEEN ACCOMPLISHED (IF APPLICABLE) _____</p> <p>NEED THIS SB (OR RELATED SB) BE IMPROVED? <input type="checkbox"/> YES <input type="checkbox"/> NO</p> <p>COMMENTS: _____</p> <p>_____</p> <p>_____</p>
--

IN-SERVICE DATA/SECTION 2

	(A)	(B)	(C)	(D)	(E)
CRITERIA	INSPECT- ABILITY ACCESS	FREQUENCY REPETITIVE INSPECTION	FREQUENCY OF DEFECTS	SEVERITY RATING	ADJACENT STRUCTURE DAMAGE
RATING					

(A) INSPECTABILITY/ACCESS RATING

- OK ♦ Inspection carried out with little or no difficulty.
- Acceptable ♦ Inspection carried out with some difficulty.
- Difficulty ♦ Inspection carried out with significant difficulty.

Note: Rating should consider difficulty of access as well as inspection technique and size of inspection area.

(B) FREQUENCY OF REPETITIVE INSPECTIONS RATING

- OK ♦ Greater than 6 years.
- Acceptable ♦ Between 2 and 6 years.
- Difficulty ♦ Less than 2 years.

(C) FREQUENCY OF DEFECTS NOTED RATING = % OF THOSE AEROPLANES BEYOND THRESHOLD ON WHICH DEFECTS HAVE BEEN FOUND

- OK ♦ No defect noted.
- Acceptable ♦ Defects noted but not of a significant amount (less than 10 %).
- Difficulty ♦ Substantial defects noted (greater than 10 %).

(D) FINDING SEVERITY RATING

- OK ♦ Airworthiness not affected.
- Acceptable ♦ Damage not of immediate concern, but could progress or cause secondary damage.
- Difficulty ♦ Airworthiness affected. Damage requires immediate repair.

(E) ADJACENT STRUCTURE DAMAGE RATING (MULTIPLE SITE DAMAGE, MULTIPLE ELEMENT DAMAGE, CORROSION, ETC.)

- OK ♦ Low rate of adjacent structural damage.
- Acceptable ♦ Medium rate of adjacent structural damage.
- Difficulty ♦ High rate of adjacent structural damage/Multiple service actions in area.